

Next-Generation Super Multitasking Machines

# ***LASER EX series***

***MU-5000V LASER EX***

***MU-6300V LASER EX***

***MU-8000V LASER EX***

***MULTUS Ø3000 LASER EX***

***MULTUS Ø4000 LASER EX***

***MULTUS Ø5000 LASER EX***





# Super Multitasking Machines

Core machines for smart factories that transcend the bounds of cutting machines

Next-Generation Super Multitasking Machines

**LASER EX** *series*

Next-Generation Super Multitasking Machines

## **LASER EX series**

**MU-5000V LASER EX / MU-6300V LASER EX**

**MU-8000V LASER EX**

**MULTUS  $\varnothing$ 3000 LASER EX / MULTUS  $\varnothing$ 4000 LASER EX**

**MULTUS  $\varnothing$ 5000 LASER EX**

Okuma has developed the LASER EX Series as smart machines to form an innovative core for revolutionizing production. The world's first super multitasking machines, these transcend the bounds of cutting and grinding, applying the latest in laser technology to make possible metal additive manufacturing, coating, and even precision hardening.



**MU-6300V LASER EX**

## Handles workpieces of many different sizes and shapes

Simultaneous rollout on the MU-V Series of 5-axis machining centers and the MULTUS U Series of multitasking machines



**MULTUS  $\varnothing$ 4000 LASER EX**

Photos used in this brochure include optional equipment. Please have a stand ready for the coaxial camera monitor.

# Going beyond cutting machines—doing the all of metalworking

These super multitasking machines (LASER EX Series) that combine the latest laser technology bring together subtractive machining with metal additive manufacturing, hardening, and coating. They are the ultimate process-intensive machines, enabling all steps from blank material to completed product to be accomplished on a single machine.



## Laser metal deposition (LMD)

- Supplies powder from nozzles and performs laser melting and bonding to parent material
- Makes possible combining and multilayering with materials of different type
- Makes possible 3D additive manufacturing, repairs, and coating

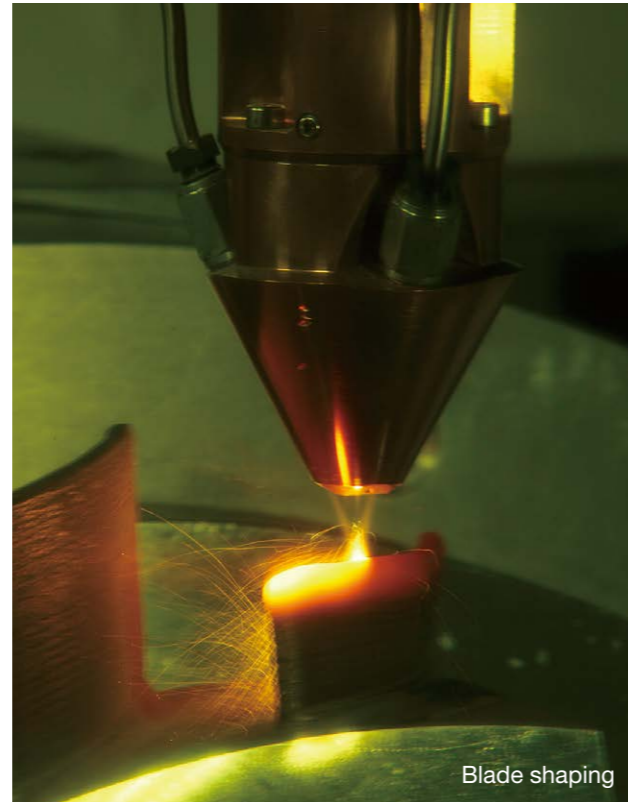

## Laser hardening

- Heating by laser radiation, with hardening by self-cooling
- Case hardening possible
- Less warpage than with high-frequency or flame hardening

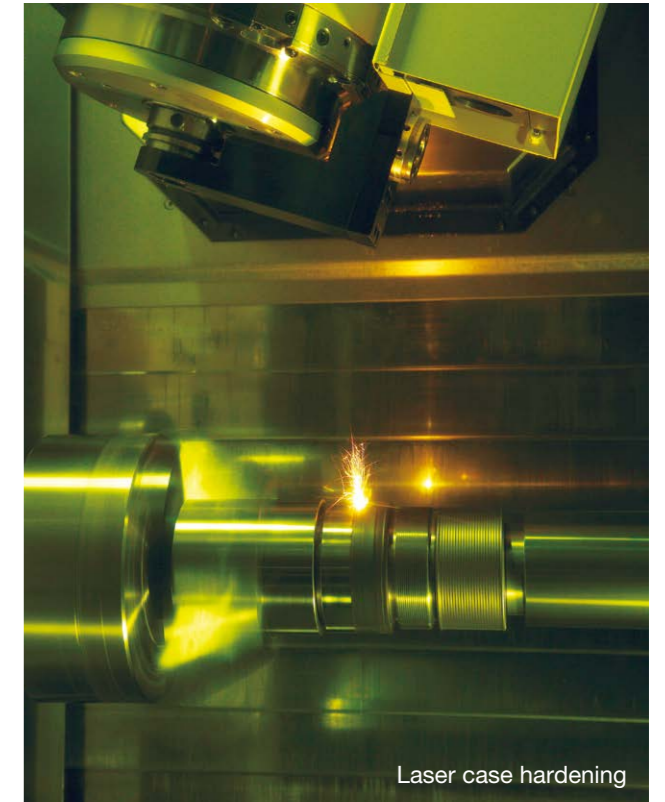

## Laser output

■ A line-up ranging from 0.6 to 4 kW to match the application

Laser type	Output	High-resolution nozzles	High-efficiency nozzles	Deposition applications	Hardening applications
Diode laser	0.6 kW	○	—	Coating (0.3 mm)	Flat hardening (width-based output)
Disk laser	1 kW	○	—	High-resolution printing	
	2 kW	○	○	High-efficiency printing	
	4 kW	○	○	Ultra-high efficiency printing Heat-resistant material	Turn hardening

■ Powder materials

- Stainless steel
- Nickel-based alloys (Inconel™ 625, 718)
- Tungsten carbide composites
- Titanium alloys
- Cobalt-chromium-molybdenum alloys
- Stellite® alloys
- Tool steel
- Aluminum alloy
- Etc

## 【 The LASER EX Series – revolutionizing production 】

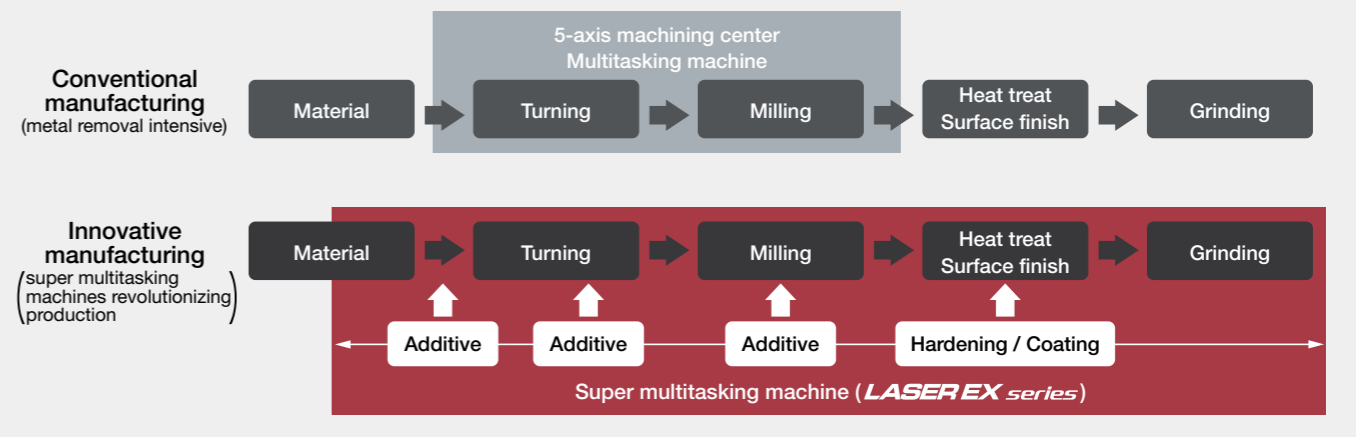

# Achieving high efficiency and high resolution with precision control

Infinitely variable control of laser spot diameters (ø0.4 to 8.5 mm) using CNC.  
 Demonstrating the highest performance matched to machining conditions with full control of accuracy.

## Blade shaping

- Processing heat-resistant alloys (Inconel™) by high-efficiency printing and high-quality simultaneous 5-axis machining

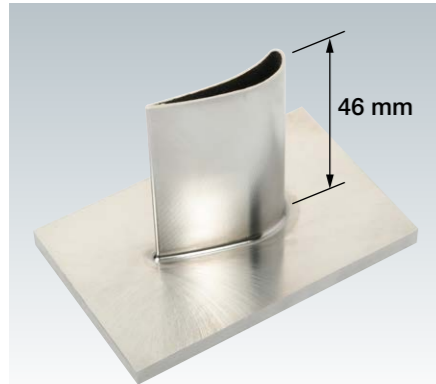

Blade: Inconel™ 625  
 Base material: SUS304

- Combines precision additive and cutting operations
- Makes possible deposition of metals of different types

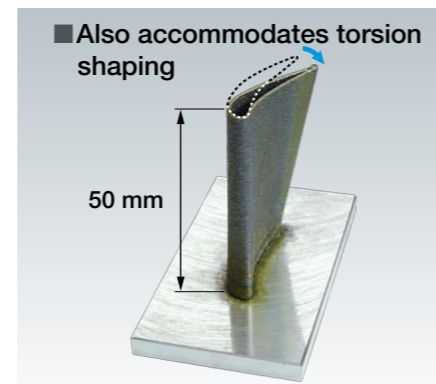

■ Also accommodates torsion shaping

Shaping is possible not only vertically, but with torsion as well.

Powder	Nozzle used	Laser output [w]	Spot diameter [mm]	Feedrate [mm/min]	Deposition height [mm/layer]	Deposition time
Inconel™ 625	High-resolution	250	ø0.6	600-800	0.225	20 min 49 sec (200 layers)

## Mesh fabrication by precision additive manufacturing

- Makes possible uniform-width forming using a stable laser
- Achieves high-resolution, thin additive manufacturing of 1 mm or less

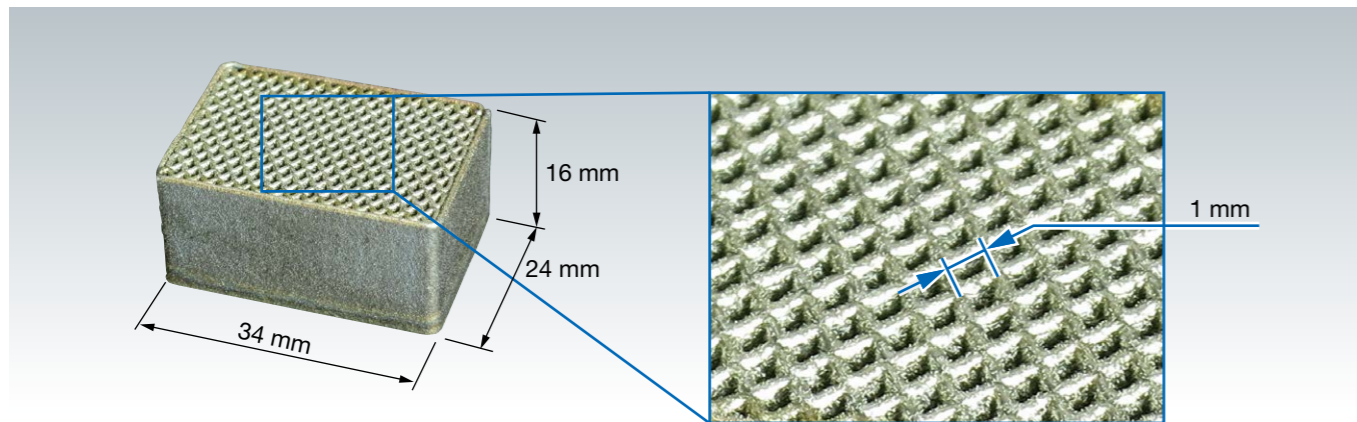

High-resolution precision manufacturing

Powder	Deposition height [mm/layer]	Deposition time
SUS420L	0.15	2 hours (100 layers)

# Revolutionizing production in a wide range of fields through application of laser technology

## Resin mold repairs

- All operations from crack removal to finishing on a single machine
- Even accommodates hard-to-cut and high-hardness materials

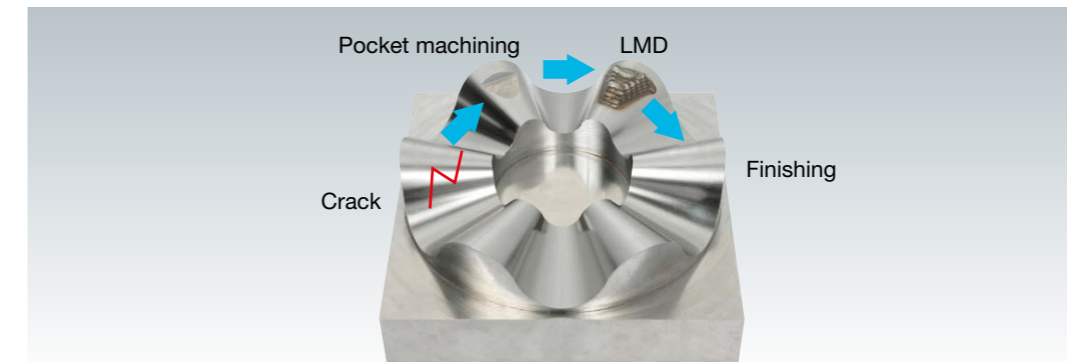

Base material: Stavax® ESR

Powder	Nozzle used	Laser output [w]	Spot diameter [mm]	Feedrate [mm/min]	Deposition height [mm/layer]	Deposition time
SUS420L	High-efficiency	1,500	ø3.0	800	0.75	58 sec (5 layers)

## Coating

- Process-intensive machining with uniform coating and finishing
- No need for sandblasting or other preprocessing
- Switchable among multiple coating materials

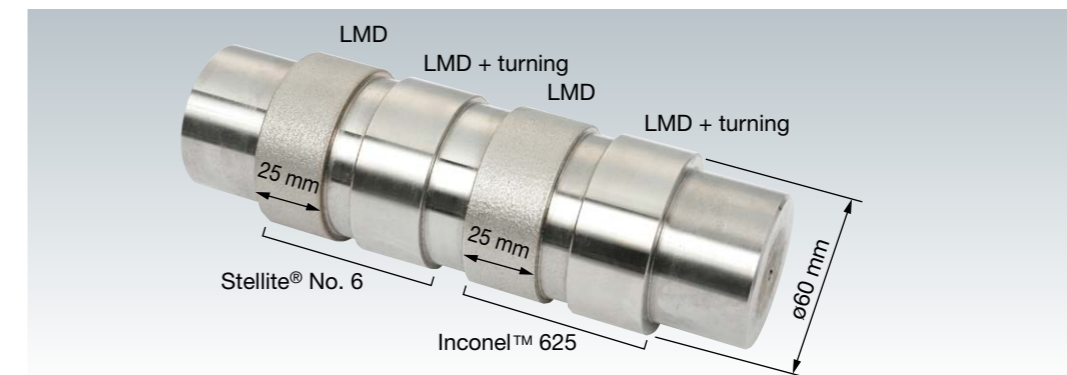

Base material: SUH3 (heat-resistant steel)

Powder	Nozzle used	Laser output [w]	Spot diameter [mm]	Feedrate [mm/min]	Deposition height [mm/layer]	Deposition time
Stellite® No. 6	High-resolution	250	ø0.4	600	0.32	20 min 25 sec (1 layer)
Inconel™ 625				800	0.44	18 min 31 sec (1 layer)

# A world's first!

## Process-intensive heat treatment

Completion of all operations from raw material to completed product by laser precision hardening

### Process-intensive turn hardening and grinding

- Cutting and grinding interrupted by heat treatment can be completed on a single machine with no setup change.
- Uniform-width turn hardening using a high-output, stable laser. Case hardening on cylindrical surfaces with no uneven hardening and little warping is possible.

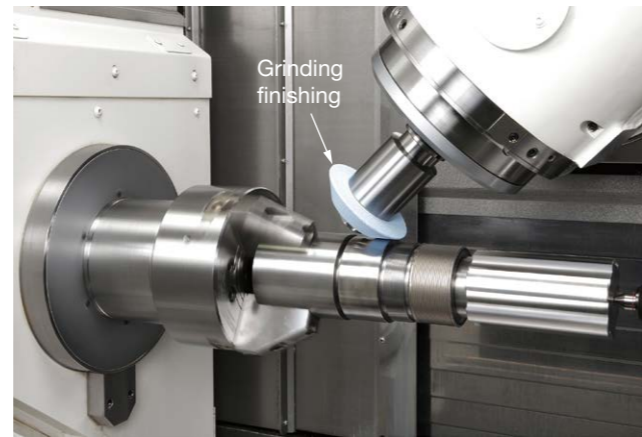
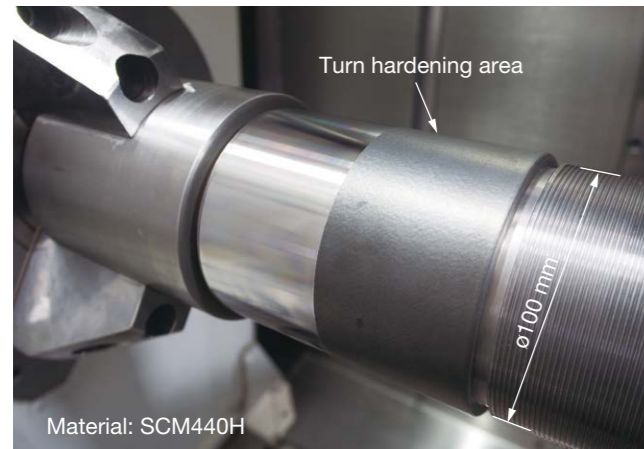

Laser beam [mm]	Hardening time	Hardness
$\square 1.2 \times 10$	4 min 25 sec (L = 110 mm)	HRC58 (depth: 0.3 mm)

### Case hardening of spline tooth surfaces

- Efficient uniform hardening at a fixed width through optics specialized for hardening

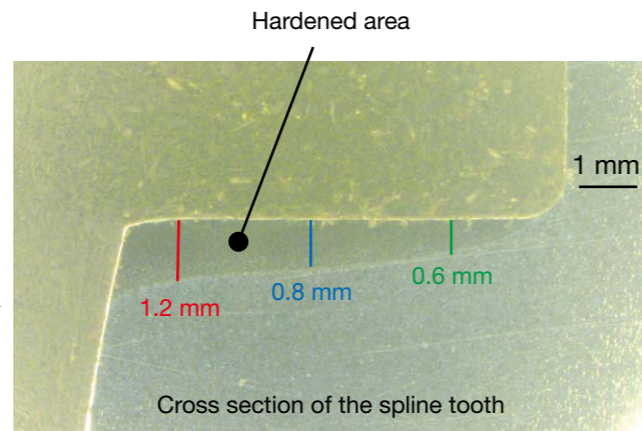

Laser beam [mm]	Hardening time	Hardness
$\square 1.2 \times 10$	2 min/pass (L = 200 mm)	HRC58 (depth: 0.8 mm)

### World-class reliability and stability to meet the quality demands for key aircraft components

Tensile strength for junctions through additive manufacturing

**Higher junction strength than the base material (forged)**

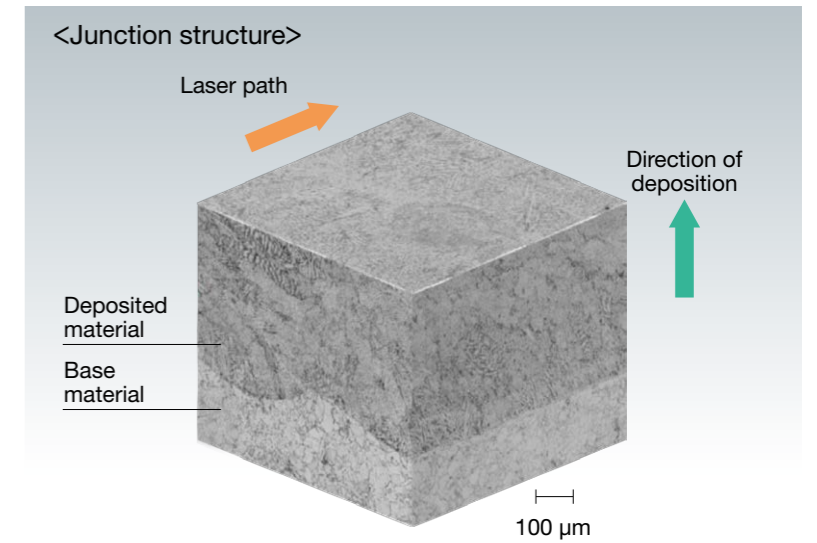
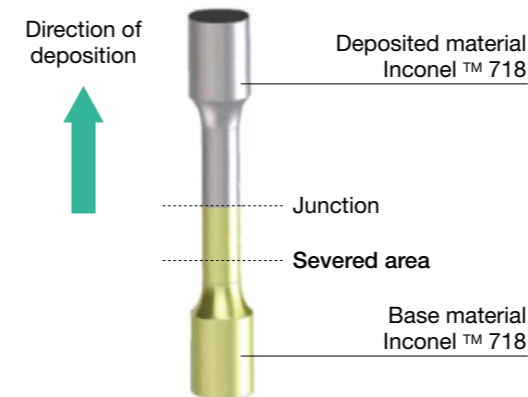

The base material and deposited material form an alloy that exhibits high junction strength.

### Laser network technology

A single laser can be connected to up to **six machines** (Optional). This allows multiple machines to share expensive laser equipment.

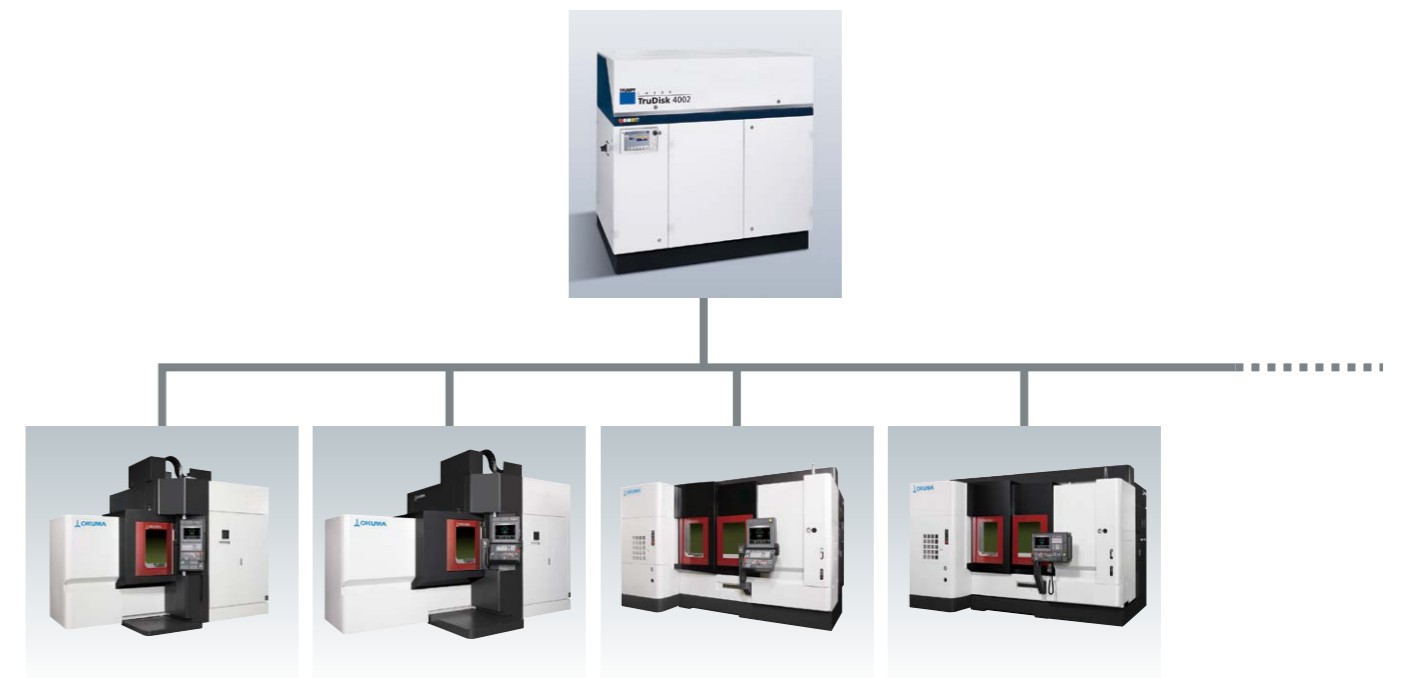

## MU-V LASER EX Series Machine Specifications

Item		Unit	MU-5000V LASER EX	MU-6300V LASER EX	MU-8000V LASER EX
Travels	X axis	mm (in.)	800 (31.50)	925 (36.42)	
	Y axis	mm (in.)	870 (34.25)		
	Z axis	mm (in.)	600 (23.62)		
	A-axis indexing angle	deg	-120 to +90 (min controlled angle 0.0001)		
	C-axis control	deg	360 (min controlled angle 0.0001)		
Table	Table size	mm (in.)	ø500 (19.69)	ø630 (24.80)	ø800 (31.50)
	Max work size	mm (in.)	ø700 × H500 (ø27.56 × H19.69)	ø830 × H550 (ø32.68 × H21.65)	ø1,000 × H550 (ø39.37 × H21.65)
	Floor to table top	mm (in.)	1,140 (44.88)	1,150 (45.28)	1,210 (47.64)
	Max load capacity	kg (lb)	500 (1,100)	600 (1,320)	700 (1,540)
	Turning spindle speed	min <sup>-1</sup>	1,000	800	
Spindle	Spindle speed (multitasking machining spindles)	min <sup>-1</sup>	50 to 8,000		
	Tapered bore		HSK-A63		
	Spindle (10 min/cont)	kW (hp)	11/7.5 (15/10)		
ATC	Tool capacity (magazine)	tools	32		
Machine size	Height	mm (in.)	3,435 (135.24)	3,525 (138.78)	3,625 (142.72)
	Floor space (w/o operator platform)	mm (in.)	3,995 × 2,750 (157.28 × 108.27)	4,850 × 2,990 (190.94 × 117.72)	5,280 × 2,990 (207.87 × 117.72)
	Weight	kg (lb)	15,500 (34,100)	17,600 (38,720)	18,500 (40,700)
CNC			OSP-P300SA		

Note: For details on machine specifications, please see the MU-V Series brochure.

## LASER EX Series Standard Specifications / Accessories

Laser oscillator	Laser output		0.6 kW
	Number of optical paths	Standard	
	1		
Cable length	20 m		
Cooler	Air-cooled		
Multi-voltage transformer <sup>*1</sup>	Installed		

\*1. The transformer unit varies according to voltage used.

## LASER EX Series Optional Specifications / Accessories

Laser oscillator	Laser output		1 kW, 2 kW, 4 kW
	Number of optical paths	Standard	
	2, 3, 4		
	Expanded		3, 4, 5, 6
Laser oscillator preparations			
Cable length <sup>*1</sup>	30 m, 40 m, 50 m, 70 m, 100 m		
Cooler	Water-cooled <sup>*2</sup>		
Cooler preparations			

\*1. For hardening specifications, only 30 m can be selected.

\*2. Factory facilities must have a water recirculator installed.

## MU-V LASER EX Series Optional Specifications / Accessories

Item	Specifications	Hardening		LMD/coating		
		Grinding	Dust explosion risk <sup>*1</sup>	Grinding	Dust explosion risk <sup>*1</sup>	
						N/A
Hardening head	Line laser □ 1.2 × 10 mm	★	★	—	—	
LMD processing head	High-resolution nozzle <sup>*2</sup>	—	—	★	★	
	High-efficiency nozzle <sup>*3</sup>	—	—			
Accessory nozzles	Ultra-high efficiency nozzle <sup>*4</sup>	—	—			
	Type of gas used <sup>*5</sup> (shielding/powder feed)	Argon/argon	—	—	★	★
Powder feeder	Number of pots	2	—	—	★	★
		4	—	—		
	Pot capacity	1.5 L	—	—	★	★
		5 L	—	—		
Reduction installed	1	—	—	★	★	
	Number of pots <sup>*6</sup>	2 to 4	—	—		
Laser processing-head coaxial camera controller		—	—	★	★	
Coaxial camera monitor		—	—	★	★	
High-hardness materials related	Chip conveyor high-hardness materials related	★	★	★	★	
Dust-proofing	Drum-filter chip conveyor		★	★	★	
	LM-guide double wipers		★	★	★	
	Ball-screw nut seal reinforcement		★	★	★	
	Spindle air purging		★	★	★	
	Dust-proofed tool-pot tilt mechanism		★	★	★	

★ : Kit specifications. ● : Required specifications. ○ : Recommended specifications. — : Not applicable

\*1. Technical consultation is required with respect to risk of explosion. Please consult Okuma.

\*2. The high-resolution nozzle is used at laser output of 1 kW or less.

\*3. The high-efficiency nozzle is used at laser output of 3 kW or less.

\*4. The ultra-high efficiency nozzle is used at laser output of 4 kW or less.

\*5. In cases where prevention of oxidation of deposited material is required, please select an argon/helium laser.

\*6. This is the number of reduction-equipped pots included in the selected number of pots. When not specified, the number is 1 for 2 pots or 2 for 4 pots.

When reduction is present, specifications are 0.01 rotation control and maximum rotation speed of 3 min<sup>-1</sup>.

When reduction is not present, specifications are 0.1 rotation control and maximum rotation speed of 6 min<sup>-1</sup>.

\*7. Used by the laser processing-head coaxial camera controller and coaxial camera monitor.

## LMD processing head



MU-V LASER EX Series



MULTUS U LASER EX Series



### High-resolution nozzle

- Width 0.8–2 mm, layers with thickness of 0.2–0.3 mm are possible
- Laser output is used at 1 kW or less



### High-efficiency nozzle

- Width 1–3 mm, layers with thickness of 0.6 mm are possible
- Laser output is used at 3 kW or less



### Ultra-high efficiency nozzle

- Width 1.5–4.5 mm, layers with thickness of 1 mm are possible
- Laser output is used at 4 kW or less

## Head for hardening



MULTUS U LASER EX Series

- 1.2-mm long × 10-mm wide laser beam

## Coaxial camera monitor

With the camera attached to the LMD processing head, machining status can be checked on the monitor. The nozzle position can be checked during nozzle exchange.



Coaxial camera monitor

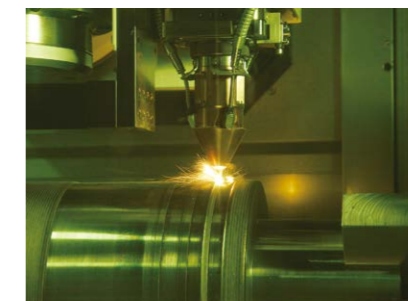

Laser processing

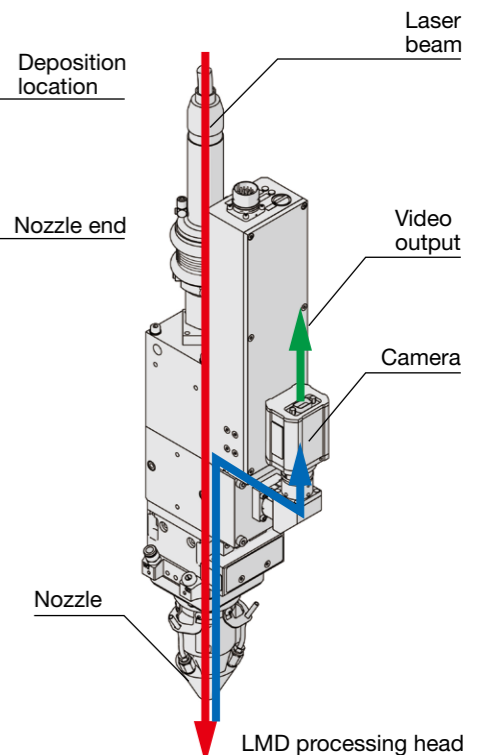

LMD processing head

## MULTUS U LASER EX Series Machine Specifications

Item	Unit	MULTUS U3000 LASER EX		MULTUS U4000 LASER EX		MULTUS U5000 LASER EX		
		1SW	2SW	1SW	2SW	1SW	2SW	
		1500	1500	1500	1500	1500	1500	
Capacity	Swing over saddle	mm (in.)	ø650 (25.59)	Upper: ø650 (25.59), Lower: ø320 (12.60)	ø650 (25.59)	Upper: ø650 (25.59), Lower: ø320 (12.60)	ø650 (25.59)	Upper: ø650 (25.59), Lower: ø320 (12.60)
	Distance between centers	mm (in.)	1,500 (59.06)				1,500 (59.06)	
	Max machining dia	mm (in.)	ø650 (25.59)	Upper: ø650 (25.59), Lower: ø320 (12.60)	ø650 (25.59)	Upper: ø650 (25.59), Lower: ø320 (12.60)	ø650 (25.59)	Upper: ø650 (25.59), Lower: ø320 (12.60)
	Max machining length	mm (in.)	1,000 (39.37)				1,000 (39.37)	
Travels	X axis*1	mm (in.)	645 (25.39)	Upper: 645 (25.39), Lower: 235 (9.25)	695 (27.36)	Upper: 695 (27.36), Lower: 235 (9.25)	695 (27.36)	Upper: 695 (27.36), Lower: 235 (9.25)
	Z axis*1	upper	1,100 (43.31)				1,100 (43.31)	
		lower	—	1,584 (62.36)	—	1,524 (60.00)	—	1,524 (60.00)
	Y axis*1	mm (in.)	250 (±125) (9.84 (±4.92))				250 (±125) (9.84 (±4.92))	
	W axis	mm (in.)	1,594 (62.76)	1,584 (62.36)	1,554 (61.18)	1,524 (60.00)	1,554 (61.18)	1,500 (59.06)
	B-axis indexing angle*1	deg	-30 to +210 (min controlled angle 0.001)				-30 to +210 (min controlled angle 0.001)	
	C-axis control	deg	360 (min controlled angle 0.0001)				360 (min controlled angle 0.0001)	
Main spindle	Spindle speed	min <sup>-1</sup>	50 to 5,000		45 to 4,200		30 to 3,000	
	Main spindle motor	kW (hp)	22/15 (30/20) (30 min/cont)				37/30 (30 min/cont)	
Opposing spindle	Spindle speed	min <sup>-1</sup>	50 to 5,000	38 to 5,000	45 to 4,200	38 to 3,800	30 to 3,000	38 to 3,800
	Opposing spindle motor	kW (hp)	22/15 (30/20) (30 min/cont)	22/15 (30/20) (20 min/cont)	22/15 (30/20) (30 min/cont)	22/15 (30/20) (20 min/cont)	32/22 (42/30) (20 min/cont)	22/15 (30/20) (20 min/cont)
Turret	Type		H1	Upper: H1 Lower: V12	H1	Upper: H1 Lower: V12	H1	Upper: H1 Lower: V12
	No. of tools		L / M: 1	Upper: L / M :1 Lower: 12	L / M: 1	Upper: L / M: 1, Lower: 12	L / M: 1	Upper: L / M: 1, Lower: 12
	Milling tool spindle	min <sup>-1</sup>	50 to 12,000				50 to 12,000	
	Milling tool spindle motor	kW (hp)	22/15/11 (30/20/15) (3 min/15 min/cont)				22/15/11 (30/20/15) (3 min/15 min/cont)	
Feedrates	Feedrates X, Z, Y axes*2	upper	X: 50, Z: 50, Y: 40				X: 50, Z: 50, Y: 40	
		lower	—	X: 25, Z: 40	—	X: 25, Z: 40	—	X: 25, Z: 40
	Feedrates W-axes	m/min	30				30	
	Feedrates C, B axes*3	min <sup>-1</sup>	C: 200, B: 30				C: 200, B: 30	
ATC	Tool capacity (magazine)	tools	40				40	
Machine size	Height*4	mm (in.)	3,125 (123.03)				3,125 (123.03)	
	Floor space (tank included)*4	mm (in.)	5,475 × 3,156 (215.55 × 124.25)				5,475 × 3,156 (215.55 × 124.25)	
	Weight	kg (lb)	16,900 (37,180)	17,900 (39,380)	17,400 (38,280)	18,400 (40,480)	17,700 (38,940)	18,700 (41,140)
CNC		OSP-P300SA				OSP-P300SA		

Note: For details on machine specifications, please see the MULTUS U Series brochure.

\*1. When an LMD head is installed, travel may be restricted.

\*2. The X-, Z-, and Y-axis rapid traverse rates on the upper turret are limited to 12 m/min when an LMD head is mounted.

\*3. The B-axis rapid traverse is limited to 1.5 min<sup>-1</sup> when an LMD head is mounted.

\*4. Dimensions with specifications for chip conveyor with drum filter.

## LASER EX Series Standard Specifications / Accessories

Laser oscillator	Laser output		0.6 kW
	Number of optical paths	Standard	
			1
Cable length	20 m		
Cooler	Air-cooled		
Multi-voltage transformer*1	Installed		

\*1. The transformer unit varies according to voltage used.

## LASER EX Series Optional Specifications / Accessories

Laser oscillator	Laser output		1 kW, 2 kW, 4 kW
	Number of optical paths	Standard	
		Expanded	
			2, 3, 4
			3, 4, 5, 6
Laser oscillator preparations			
Cable length*1	30 m, 40 m, 50 m, 70 m, 100 m		
Cooler	Water-cooled*2		
Cooler preparations			

\*1. For hardening specifications, only 30 m can be selected.

\*2. Factory facilities must have a water recirculator installed.

## MULTUS U LASER EX Series Optional Specifications / Accessories

Item	Specifications	Hardening		LMD/coating		
		Grinding		Dust explosion risk*1		
		N/A	AVL	N/A	AVL	
Hardening head	Line laser □ 1.2 × 10 mm	★	★	—	—	
LMD processing head	High-resolution nozzle*2	—	—	★	★	
	high-efficiency nozzle*3	—	—			
Accessory nozzles	Ultra-high-efficiency nozzle*4	—	—			
	Type of gas used*5 (shielding/powder feed)	Argon/argon	—	—	★	★
Powder feeder	Number of pots	2	—	—	★	★
		4	—	—		
	Pot capacity	1.5 L	—	—	★	★
		5 L	—	—		
Reduction installed	1	—	—	★	★	
	Number of pots*6	2 to 4	—	—		
Laser processing-head coaxial camera controller		—	—	★	★	
Coaxial camera monitor		—	—	★	★	
High-hardness materials related	Guideway double wipers	★	★	★	★	
	Coolant and sludge measures	★	★	★	★	
	Chip coolant blower	★	★	★	★	
	Chip conveyor high-hardness materials related	★	★	★	★	
Dust-proofing	Drum-filter chip conveyor		★	★	★	
	Spindle air purging (main spindle, opposing spindle, and H1 turret)		★	★	★	
	Ball-screw double wipers		★	★	★	
	Forced lubrication of E/Z-axis ball screw and guideway		★	★	★	
	Forced lubrication of ready-station ball screw and guideway		★	★	★	
	Ball-screw nut seal reinforcement		★	★	★	
Dust collection and anti-explosion measures	Dust-proofed ATC-shutter open/close cylinder		★	★	★	
	Mist collector	●	●	●	—	
	Mist collector (with wetting nozzle)	—	—	—	●	
	Dust collector	—	—	●	—	
	Dust collector (dust-explosion pressure diffuser)	—	—	—	●	
	Fire damper	—	—	○	●	
	Automatic fire extinguisher (argonite type)	—	—	○	●	
Explosion vent (dust-explosion pressure-diffusion port inside machining chamber)	—	—	—	★		
Other	Block skip; 3 sets	○	○	○	○	
	2 100-V 1-A electrical outlets (inside CNC cabinet) *7			★	★	

★: Kit specifications, ●: Required specifications

○: Recommended specifications, —: Not applicable

\*1. Technical consultation is required with respect to risk of explosion. Please consult Okuma.

\*2. The high-resolution nozzle is used at laser output of 1 kW or less.

\*3. The high-efficiency nozzle is used at laser output of 3 kW or less.

\*4. The ultra-high efficiency nozzle is used at laser output of 4 kW or less.

\*5. In cases where prevention of oxidation of deposited material is required, please select an argon/helium laser.

\*6. This is the number of reduction-equipped pots included in the selected number of pots.

When not specified, the number is 1 for 2 pots or 2 for 4 pots.

When reduction is present, specifications are 0.01 rotation control and maximum rotation speed of 3 min<sup>-1</sup>.

When reduction is not present, specifications are 0.1 rotation control and maximum rotation speed of 6 min<sup>-1</sup>.

\*7. Used by the laser processing-head coaxial camera controller and coaxial camera monitor.



## Working Ranges

Unit: mm (in.)

### MULTUS U5000 LASER EX (2SW, LMD/coating)

B axis: 90°

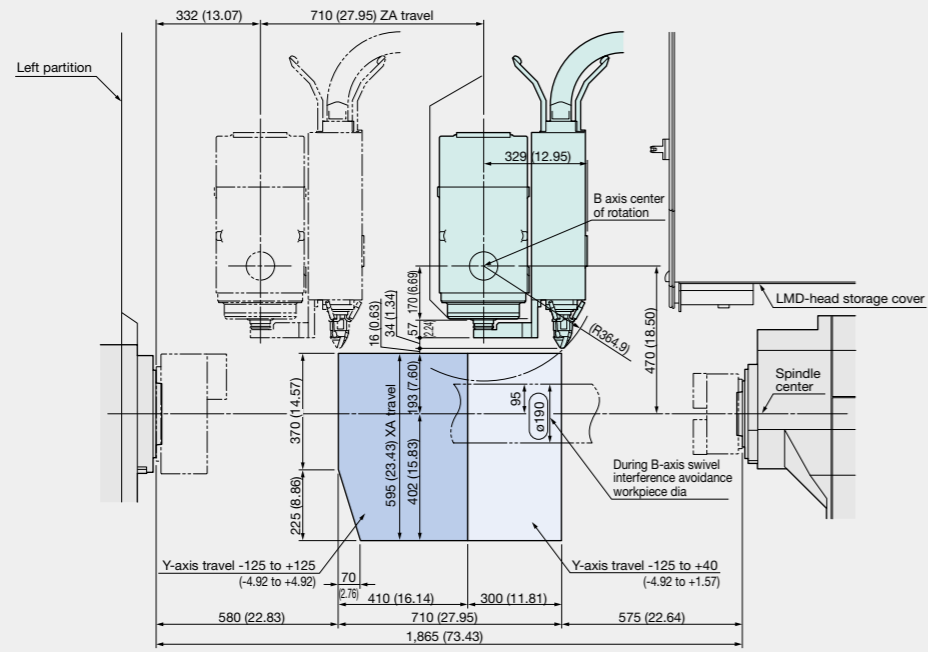

### MU-5000V LASER EX

#### Dimensional and Installation Drawings (LMD/coating, laser output: 4 kW, powder feeder: 2 pots)

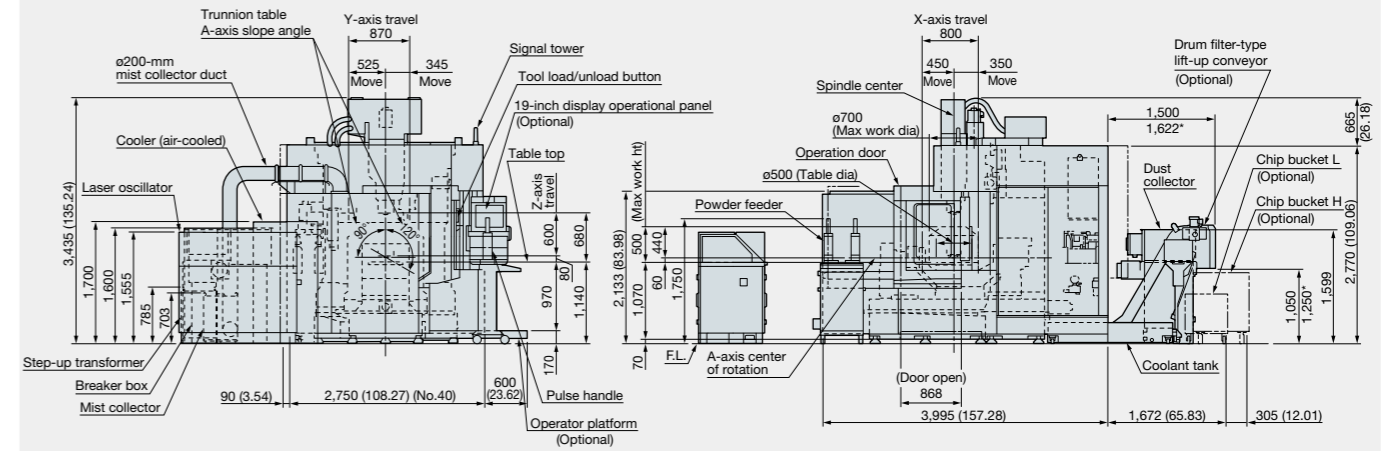
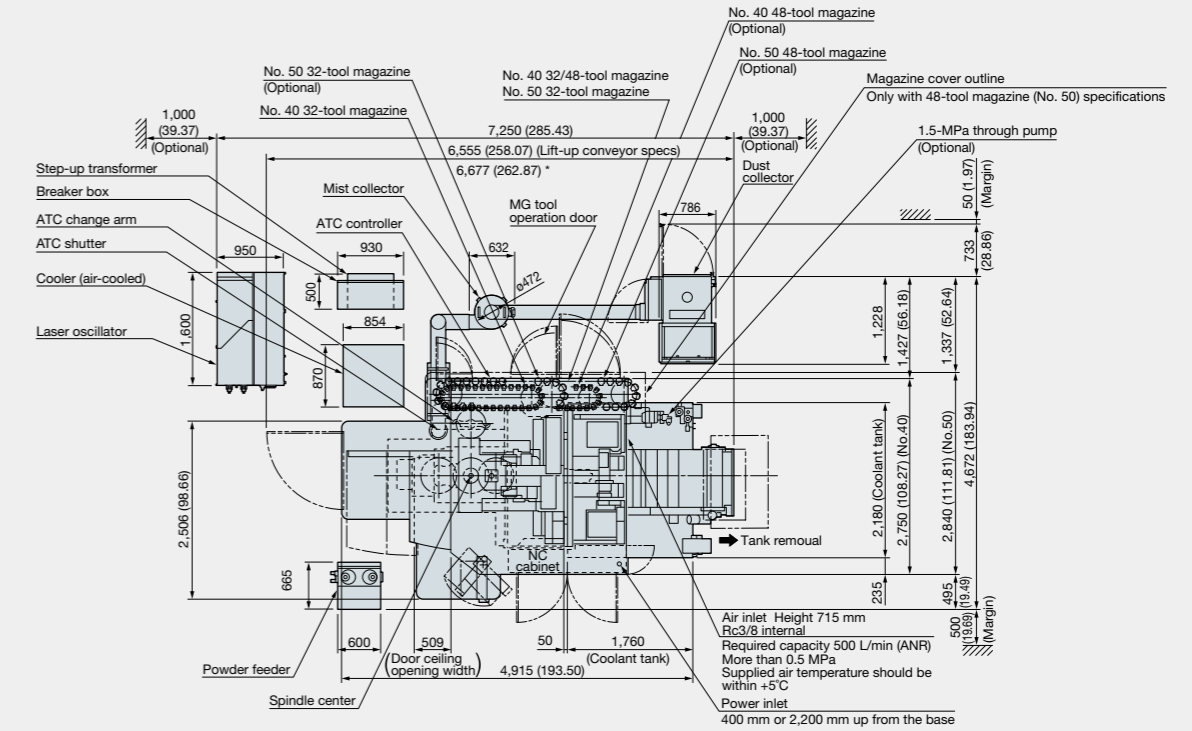

\* Drum filter-type lift-up conveyor  
Height: 1,200 mm (47.24 in.) (Optional)

Unit: mm (in.)

**MU-6300V LASER EX**  
 Dimensional and Installation Drawings (LMD/coating, laser output: 4 kW, powder feeder: 2 pots)

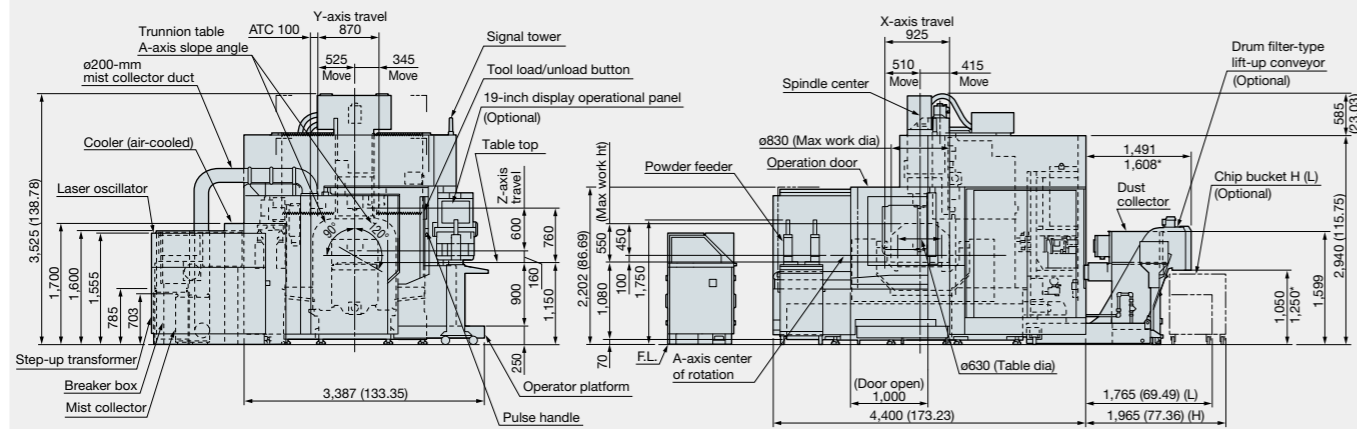
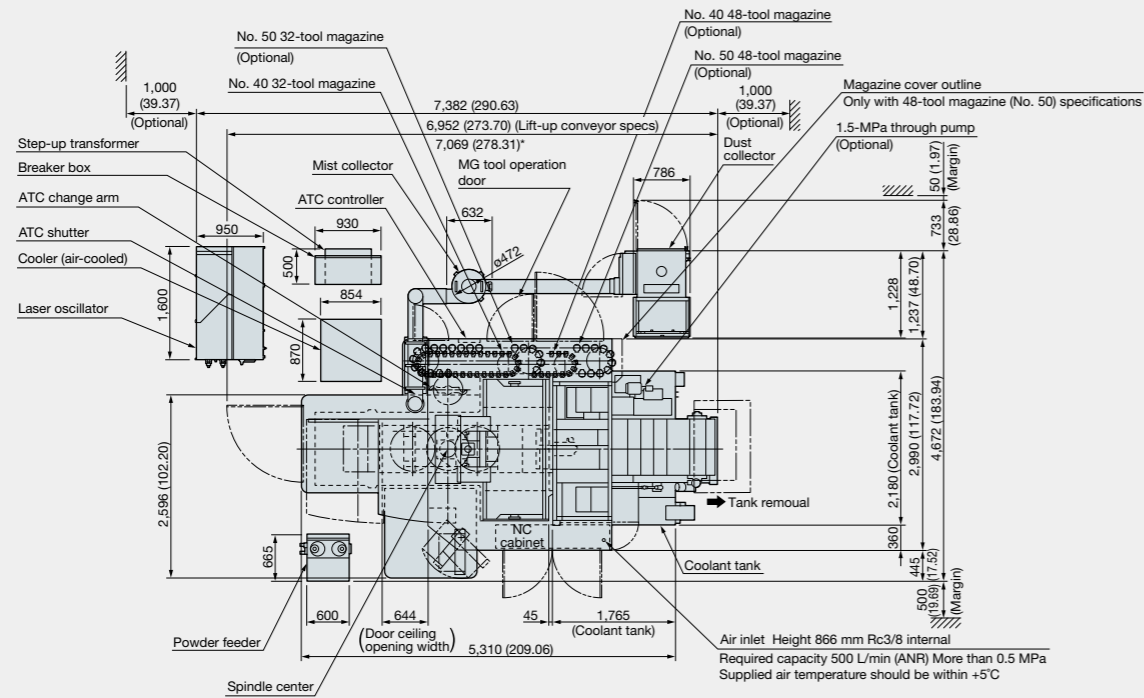

\* Drum filter-type lift-up conveyor  
 Height: 1,200 mm (47.24 in.) (Optional)

Unit: mm (in.)

**MU-8000V LASER EX**  
 Dimensional and Installation Drawings (LMD/coating, laser output: 4 kW, powder feeder: 2 pots)

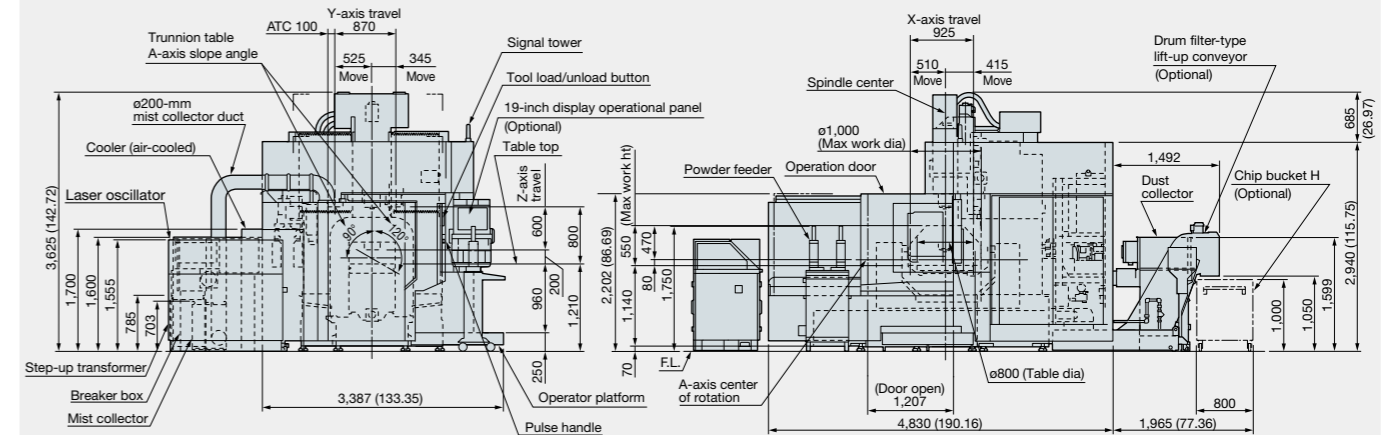
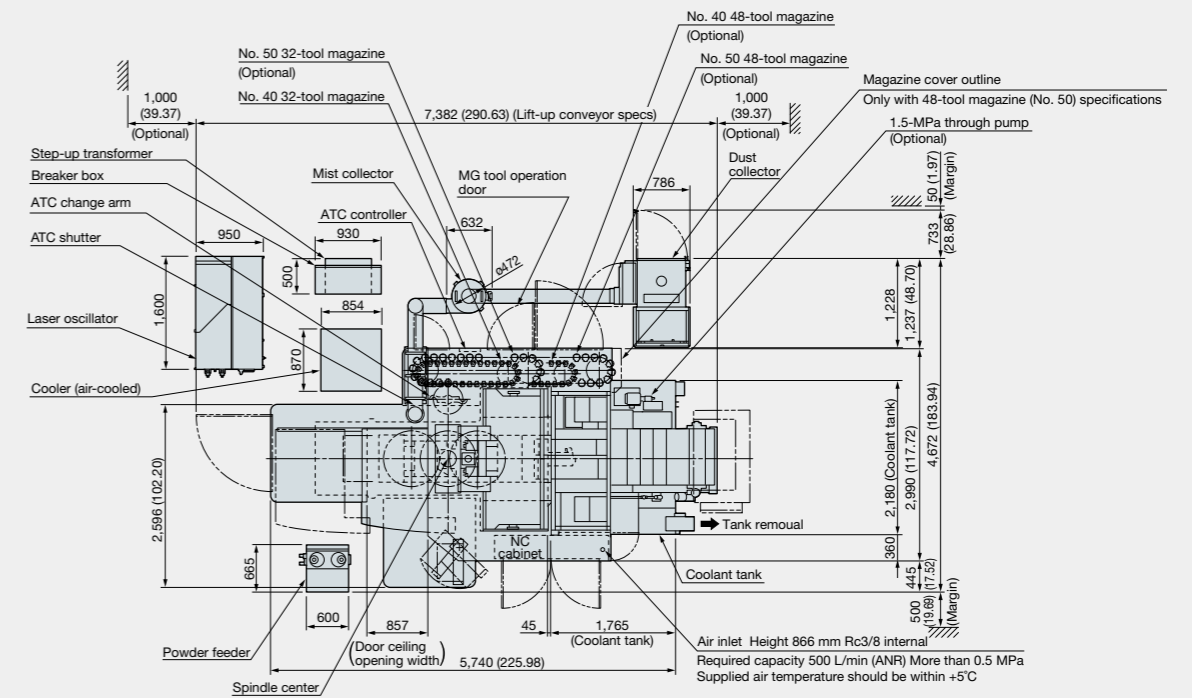

Unit: mm (in.)

**MULTUS U3000 LASER EX/MULTUS U4000 LASER EX**  
 Dimensional and Installation Drawings (2SW, LMD/coating, laser output: 4 kW, powder feeder: 2 pots)

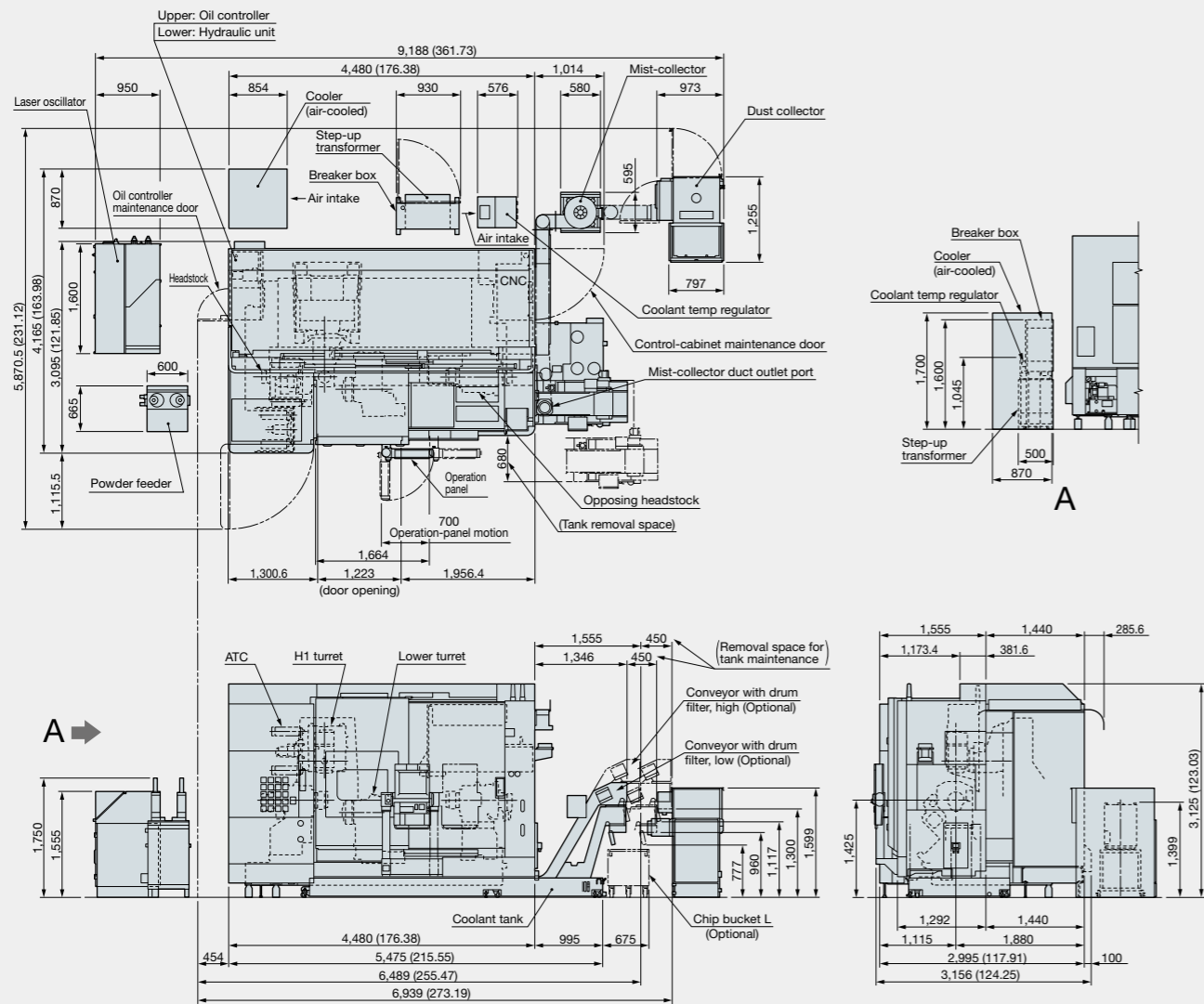

**MULTUS U5000 LASER EX**  
 Dimensional and Installation Drawings (2SW, LMD/coating, laser output: 4 kW, powder feeder: 2 pots)

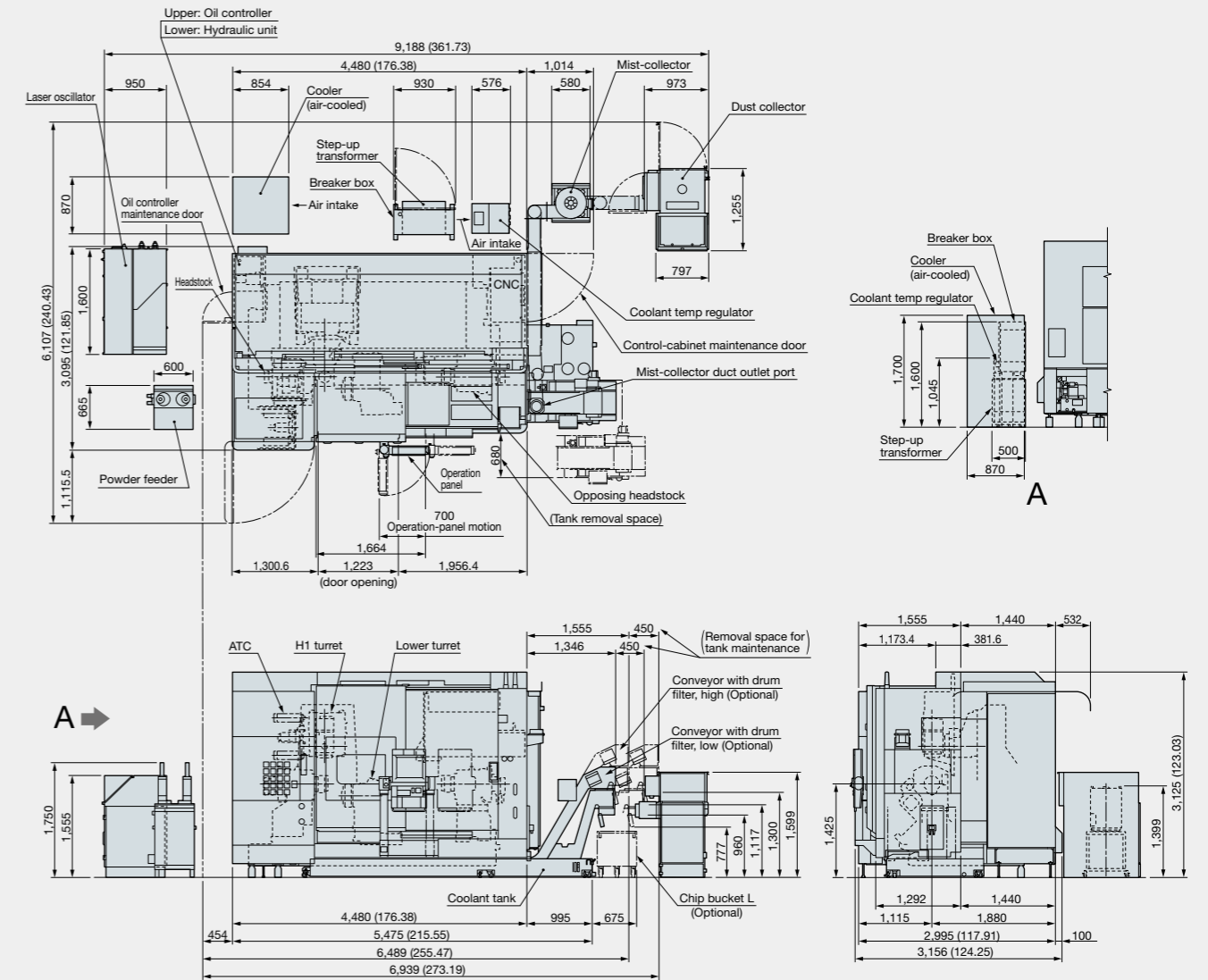

Unit: mm (in.)

When using Okuma products, always read the safety precautions mentioned in the instruction manual and attached to the product.

The specifications, illustrations, and descriptions in this brochure vary in different markets and are subject to change without notice.  
Pub.No.LASER EX series-E-(3d)-100 (Jul 2018)

**⚠ WARNING**

Eyes and skin may be exposed to laser radiation, if the laser light is not placed under a protective cover! Laser light can burn the skin. Direct or scattered laser light can permanently damage the eyes.

- ▶ Implement necessary protective measures according to laser class.

Health risk due to metal powder!

Depending on the powder type, it may cause irritations, poisoning or acid burns of the skin and eyes.

Metal powder causes permanent damage to the lungs.

- ▶ Do not use metal powders with substances harmful to health such as beryllium.
- ▶ When conducting operations that disperse metal cuttings, wear a dust-proof mask, protective gloves, and protective eye wear.
- ▶ Wear dust repellent clothing. Change the contaminated clothing immediately.
- ▶ Avoid raising of metal powder during cleaning, do not use compressed air for cleaning.
- ▶ Vacuum cleaning of the work area must be adapted to the processing task.
- ▶ Do not eat, drink or smoke at the workplace, do not keep any food.
- ▶ In case of contact with powder, thoroughly wash the exposed body parts immediately.
- ▶ Do not wear contact lenses.
- ▶ Thoroughly wash the hands after completing work or before breaks.

Risk of burns when touching the hot workpiece. This may result in skin injuries.

- ▶ Remove hot workpieces using an appropriate tool.

- ▶ Wear protective gloves, if necessary.

Health hazard due to metal powder!

Irritation, poisoning or caustic injury to the skin and the eyes could occur, depending on the type of powder. Metal powder results in permanent lung damage.

- ▶ Wear a fine dust mask.

If the laser beam exit and the processing point are not placed in a protective cover, your eyes and your skin may be exposed to laser light!

Laser light can burn your skin or irreparably damage your eyes.

- ▶ Do not put your hands between focusing optics and workpiece while laser light is emitted.
- ▶ Wear laser safety goggles, suitable for the wavelength of the laser light.

**⚠ DANGER**

Risk of fire and explosion due to metal powder!

- ▶ Use of magnesium powder is prohibited.
- ▶ Do not smoke in the working area of the machine.
- ▶ Do not place any (additional) ignition sources in the working area.
- ▶ Use explosion-proof industrial vacuum cleaner for all cleaning operations in the working area.
- ▶ Use a separate vacuum cleaner for each powder group.
- ▶ Have fire extinguishers and fire extinguishing systems for metal fires always on hand.
- ▶ Clean the work area regularly.

While carrying out maintenance work on the laser device you may have to deal with parts dangerous for persons and material.

Improper or incautious procedures may cause injuries or material damage.

Metal powder can enter the focusing optics and soil or damage it.

- ▶ Maintenance work may be carried out by trained personnel only.
- ▶ Any work at the electrical equipment may only be performed by a skilled electrician.
- ▶ Always observe the warning notes in these maintenance instructions.
- ▶ Switch off the laser device before starting maintenance work.
- ▶ Open the focusing optics only in a suitable clean-room environment.

Actions carried out in order to rectify causes of malfunctions might involve risks to you, to other persons or to material property.

If such risks are not avoided, they can lead to death, serious injuries or considerable damage to property.

- ▶ Causes for malfunctions may only be remedied by persons who are sufficiently familiar with the laser device.
- ▶ Turn off the laser device, if it does not have to be connected for the elimination of the malfunction.
- ▶ Check the parts that carry dangerous voltage during operation for absence of voltage before touching them.
- ▶ Wear the personal protective equipment if required for the corresponding action (e.g. laser safety goggles, safety gloves).
- ▶ Observe the safety instructions of the manual and of other documents.

**⚠ WARNING**

This laser product uses a Class 4 invisible laser for processing and a Class 3R visible laser for positioning.

- ▶ Class 4 invisible laser: Avoid eye or skin exposure or direct or scattered radiation. Never look into the laser beam or allow skin contact.
- ▶ Class 3R visible laser: Avoid direct eye exposure.

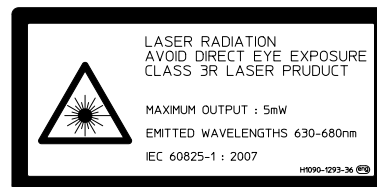

**OKUMA Corporation**

Oguchi-cho, Niwa-gun,  
Aichi 480-0193, Japan  
TEL: +81-587-95-7825 FAX: +81-587-95-6074

This product is subject to the Japanese government Foreign Exchange and Foreign Trade Control Act with regard to security controlled items; whereby Okuma Corporation should be notified prior to its shipment to another country.