

MA-4000H

Horizontal Machining Center



MA-4000H

Horizontal Machining Center

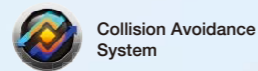

Pursuing automation, manpower saving, and operability to easily improve productivity even for beginners

Labor shortage and a decrease in veteran machinists at the shop floor. One of the answers to these serious social issues is the MA-4000H horizontal machining center. The MA-4000H has been thoroughly pursuing "long-term stable automatic operation (machine that does not stop)" as well as "productivity improvement" and "decarbonization and energy saving." It achieves one of the largest machining areas in its class in a compact floor space and improves area productivity. It maximizes the throughput of production processing by increasing the operating rate through stable production and shortening the actual and non-machining time. In addition, the machine autonomously determines its own condition and is advancing its evolution and growth as an intelligent machine tool that enables decarbonization and energy saving while maintaining high accuracy and high productivity easily even for beginners. In order to respond to the increasing demand for automation, this one machine that achieves a "smart machine that can produce in an orderly manner even without people attended" will support the resolution of various social issues.

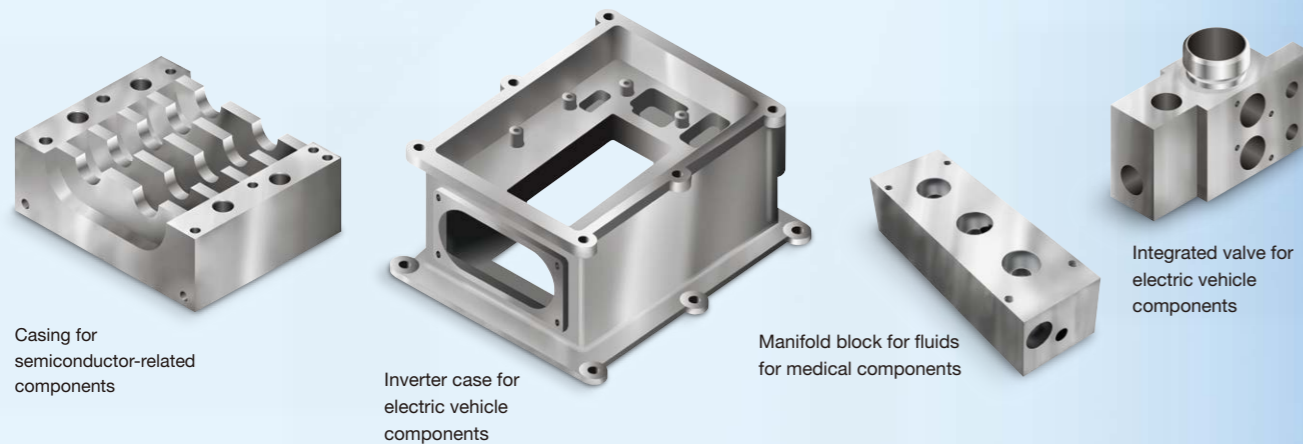

Casing for semiconductor-related components

Inverter case for electric vehicle components

Manifold block for fluids for medical components

Integrated valve for electric vehicle components

Photographs and images used in this brochure may include optional equipment.



Outstanding dimensional stability greatly shortens compensation and warm-up

Reliable machining with high accuracy and excellent thermal stability

The Thermo-Friendly Concept is an Okuma Intelligent Technology intended to achieve amazing machining accuracy with unique structural design and thermal deformation control technology. It eliminates the need for cumbersome dimensional compensation and warm-up and demonstrates outstanding dimensional stability, even when operation continues over many hours or when the ambient temperature in the factory changes.



Thermo-Friendly Concept

The Okuma Intelligent Technology that enables machines to autonomously maintain high accuracy stability

Thermo-Friendly structure gives outstanding thermal stability

Forced cooling and restraining of thermal deformation

- 1 Minimal temperature deviation
- 2 Manageable thermal deformation
- 3 Accurate compensation

Thermo Active Stabilizer—Construction (TAS-C)

Thermo Active Stabilizer—Spindle (TAS-S)

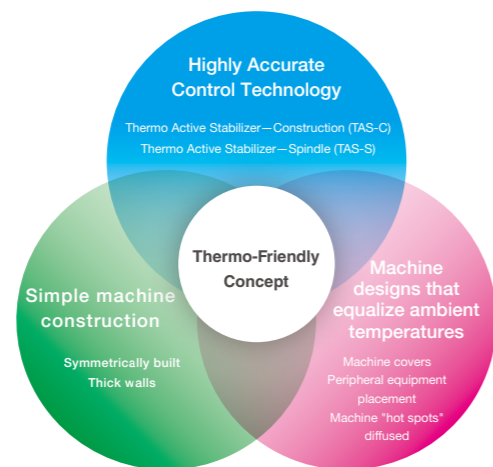

Machining dimensional change over time minimized with outstanding dimensional stability

Eliminate waste with the Thermo-Friendly Concept

Okuma's Thermo-Friendly Concept achieves high dimensional stability not only when the room temperature changes, but also at machine startups or when machining is resumed. The warm-up operation time to stabilize thermal deformation is shortened, and the burden of dimensional correction when resuming machining is reduced.

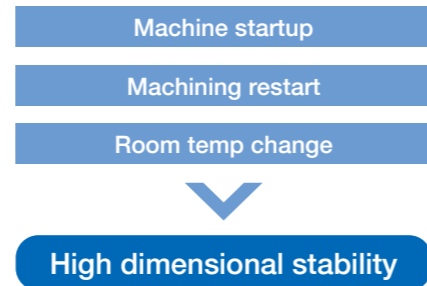

TAS-C Thermo Active Stabilizer - Construction

When machining under changing ambient temperatures, machining dimensional changes are affected by expanding/contracting machine components as well as workpiece position. TAS-C, based on machine thermal characteristics, with appropriately placed temperature sensors and feed axis position data, will predict and accurately control thermal deformation in machine construction when ambient temperatures change.

TAS-S Thermo Active Stabilizer - Spindle

Thermal deformation of the spindle changes greatly both when the spindle is turning and when it is stopped, affecting machining accuracy. TAS-S considers not only spindle temperature information but also spindle rotation, spindle speed changes, and spindle stoppage. Thermal deformation of the spindle is accurately controlled even when spindle speed changes frequently.

Outline of thermal deformation control (TAS-C, TAS-S)

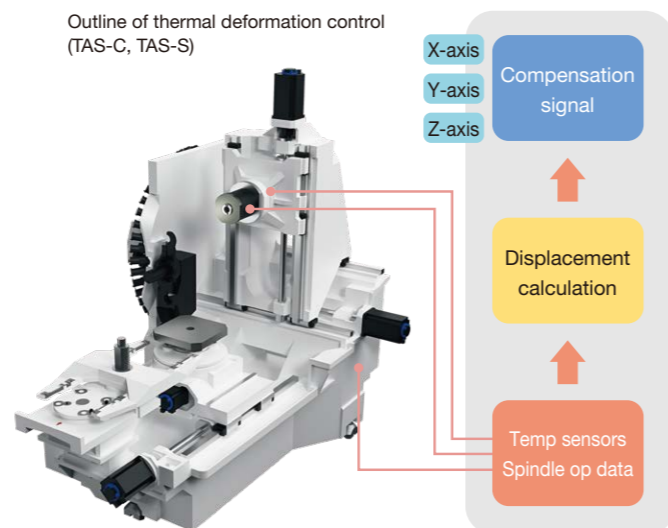

time and improves productivity

Reliable machine structure that achieves machining with high accuracy and high efficiency

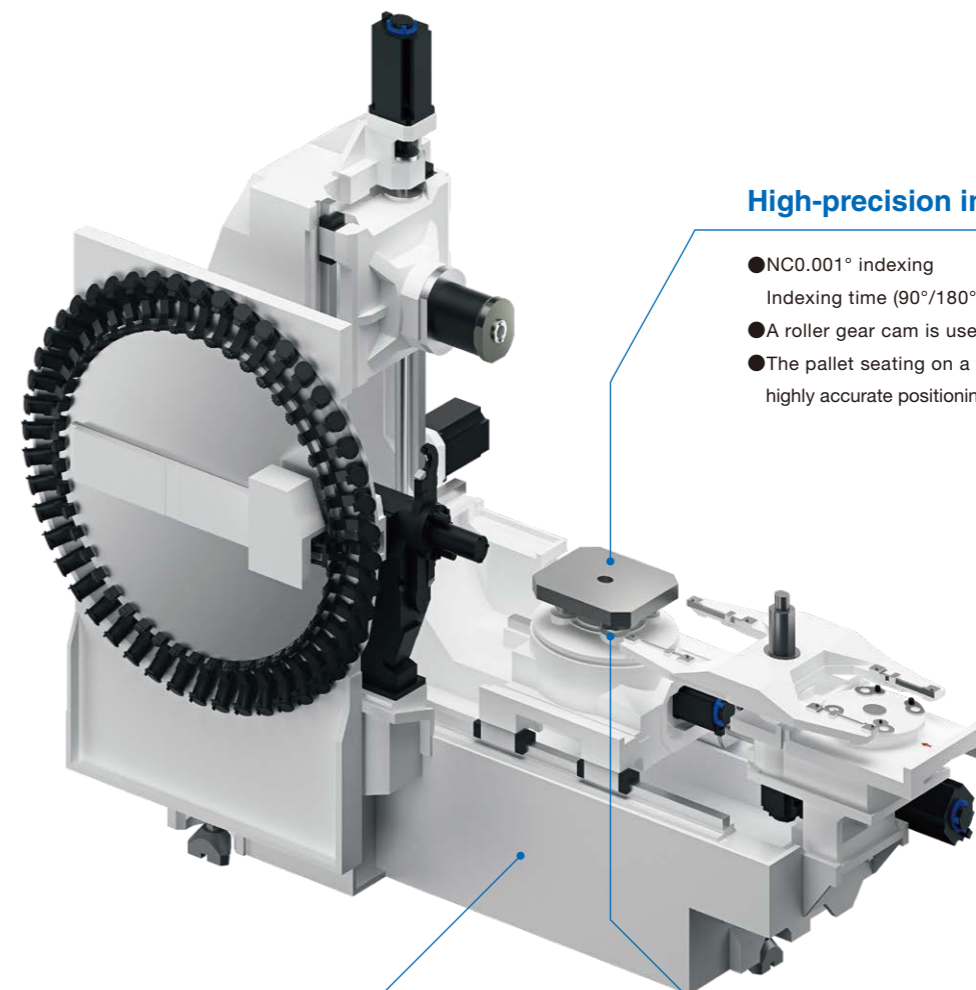

High-precision indexing table

- NC0.001° indexing
Indexing time (90°/180°) 0.8 sec/0.98 sec
- A roller gear cam is used for the drive
- The pallet seating on a tapered cone achieves highly accurate positioning and excellent durability.

Highly rigid 3-point support bed

Easy installation thanks to bed that does not twist. Supporting stable, high accuracy over a long period.

Highly rigid B-axis bearings

The highly rigid table also enables steel machining in the upper part of the Y-axis. Machining with high efficiency is achieved throughout the entire machining area.

Achieving high-accuracy machining

MA-4000H with AbsoScale; actual data (measurement method based on ISO 230-2)

The exactness of bi-directional positioning

X-axis (travel 560 mm)	2.0 μm
Y-axis (travel 650 mm)	3.7 μm
Z-axis (travel 685 mm)	2.6 μm

Bi-directional repeatability

X-axis (travel 560 mm)	0.8 μm
Y-axis (travel 650 mm)	2.7 μm
Z-axis (travel 685 mm)	1.4 μm

Note: The "actual data" referred to above represent examples of data obtained by using ISO 230-2 test methods done at Okuma factories, and they are not guaranteed values.

The lineup of highly rigid and highly torqued spindles

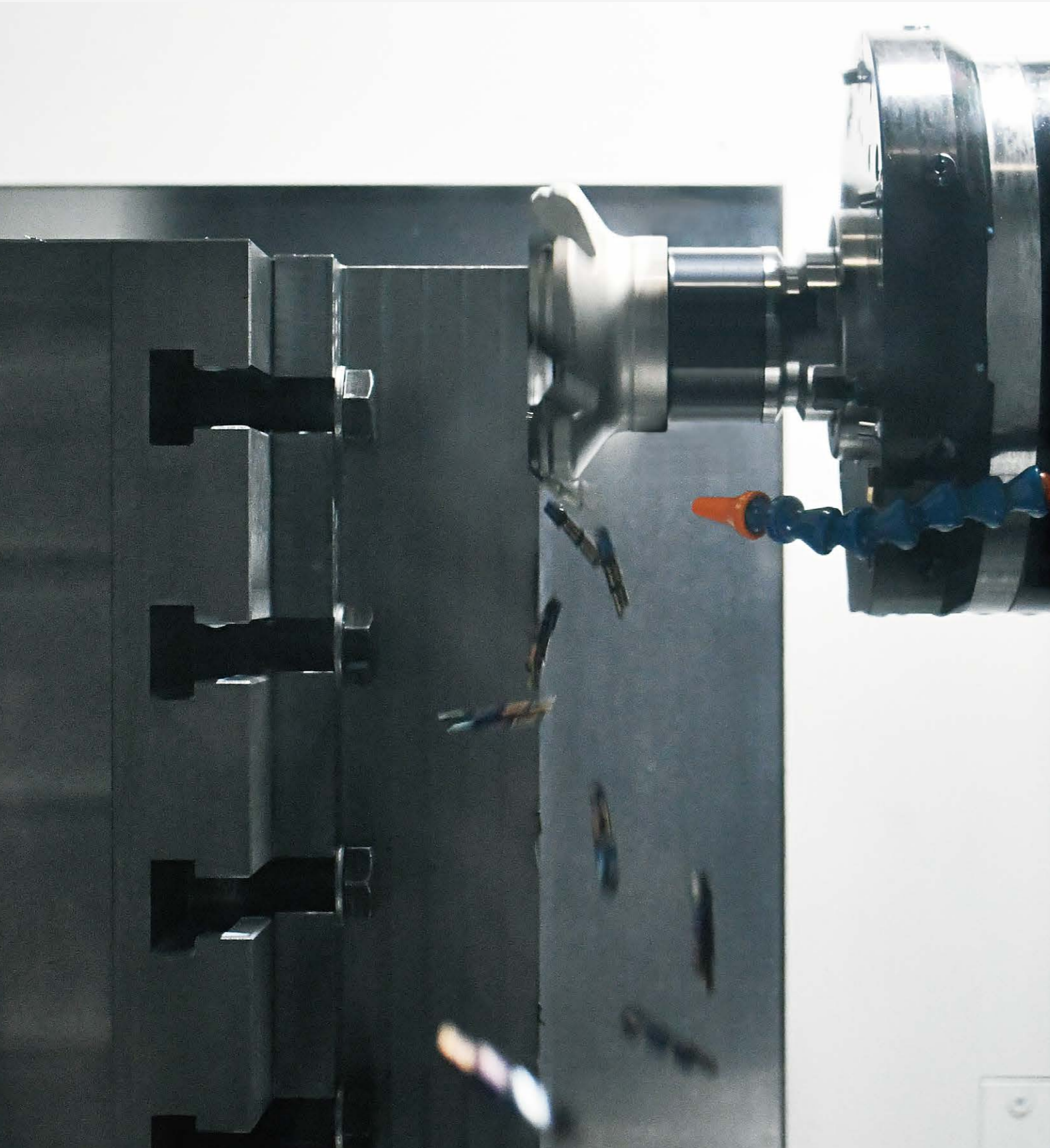

The spindle lineup

For highly efficient machining of workpieces, mainly steel materials

Standard spindle No. 40

Spindle speed:
15,000 min⁻¹

Max output:
38/18.5 kW
(40%ED/cont)

Max torque:
242/148 N-m
(20%ED/cont)

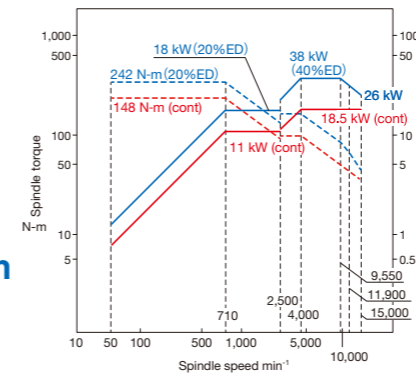

For a wide range of machining, from aluminum to steel

High-speed spindle No. 40 for aluminum applications (option)

Spindle speed:
20,000 min⁻¹

Max output:
43/22 kW
(15%ED/cont)

Max torque:
137/54 N-m
(10%ED/cont)

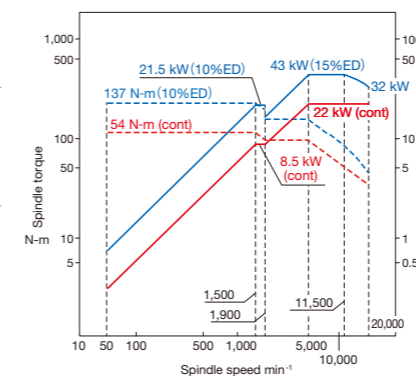

Material : A5052 actual data

Cutting Capacity **5,180 cm³/min** (end milling)

Tool	Spindle speed min ⁻¹	Cutting Speed m/min	Feed rate mm/min	Cutting Width mm	Cutting Depth mm
ø25 roughing end mill, 3 flutes (carbide)	8,000	628	8,000	18.5	35

Material : S45C actual data

Cutting Capacity **483 cm³/min** (face milling)
704 cm³/min (end milling)

Tool	Spindle speed min ⁻¹	Cutting Speed m/min	Feed rate mm/min	Cutting Width mm	Cutting Depth mm
ø100 face mill, 7 blades (carbide)	955	300	2,300	70	3
ø20 roughing end mill, 7 flutes (carbide)	4,000	251	8,800	4	20

Material : A5052 actual data

Cutting Capacity **4,022 cm³/min** (face milling)
4,340 cm³/min (end milling)

Tool	Spindle speed min ⁻¹	Cutting Speed m/min	Feed rate mm/min	Cutting Width mm	Cutting Depth mm
ø63 face mill, 5 blades (carbide)	8,000	1,583	12,000	44	7.6
ø25 roughing end mill, 3 flutes (carbide)	8,000	628	8,000	15.5	35

For powerful machining of castings and cast steel parts

High-power spindle No. 40 (option)

Spindle speed:
12,000 min⁻¹

Max output:
38/26 kW
(40%ED/cont)

Max torque:
302/148 N-m
(10%ED/cont)

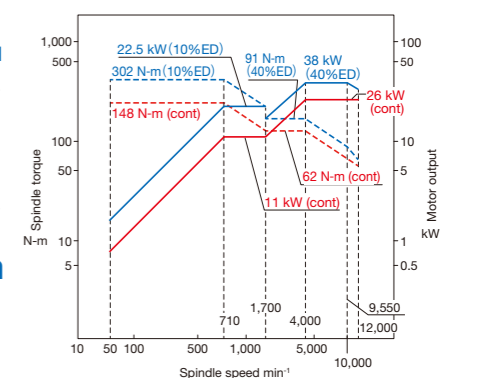

Material : FCD450 actual data

Cutting Capacity **809 cm³/min** (face milling)

Tool	Spindle speed min ⁻¹	Cutting Speed m/min	Feed rate mm/min	Cutting Width mm	Cutting Depth mm
ø125 face mill, 8 blades (carbide)	710	279	2,200	87.5	4.2

Note: The "actual data" referred to above for this brochure represent examples, and may not be obtained due to differences in specifications, tooling, cutting condition, and others.

Wasted time is eliminated to shorten machining time

Cycle time reduction by shortening non-cutting time

Agile machine operation

Rapid traverse	X-Y-Z axes 60 m/min (2,362 ipm)
Rapid traverse acceleration (max)	X-Y axes 1.0 G Z-axis 1.1 G^{*1}
Pallet change	6.6 sec^{*2} 7.1 sec^{*3}
Table indexing time	0.8 sec^{*1/90°} 0.98 sec^{*1/180°}

^{*1}. At low inertia
^{*2}. MAS standard measurements (formerly JIS B 6013)
^{*3}. ISO 10791-9 (2001) (JIS B 6336-9) measurements

High-speed machining example of aluminum mass production

Non-machining time can be shortened by shortening the operation time such as an increase in the rapid traverse acceleration and tool change. The reduction of the machining time leads to an increase in productivity over the same amount of time.

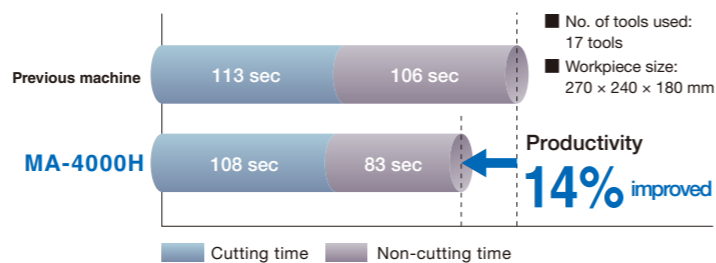

Reduced ATC times

Disc-type ATC magazine + ATC electric shutter

The ATC disk magazine provides faster operations. The farthest tool magazine indexing time possible is 5.1 seconds. In addition, an ATC electric shutter is installed as standard. Operating time is shortened by changing the ATC shutter from an air-driven type to an electric type. With the electric type, the position of the shutter can be grasped, so synchronous control of the shutter and the tool change arm eliminates wasted movements to shorten the tool change time.

ATC tools	48 tools
ATC time T-T^{*1}	0.94 sec (tool mass: 4 kg or less) 1.24 sec (tool mass: 4 kg or more)
CTC min^{*2}	2.15 sec (tool mass: 4 kg or less) 2.46 sec (tool mass: 4 kg or more)

Farthest pot indexing 5.1 sec

^{*1}. MAS standard measurements (formerly JIS B 6013)
^{*2}. ISO 10791-9 (2001) (JIS B 6336-9) measurements

Tool change time is shortened by reducing residual coolant discharge time

Suction of excess coolant in spindle

Residual coolant in tools is removed instantly in 0.6 seconds (actual value for drill tools). The suction of coolant in spindles eliminates the need for air blowing to remove residual coolant (at least 15 seconds), and so shortens tool change time.

Coolant suction time 0.6 sec*

* The coolant suction time varies depending on the tool.
 Note: It can be selected in the thru-spindle coolant specification.

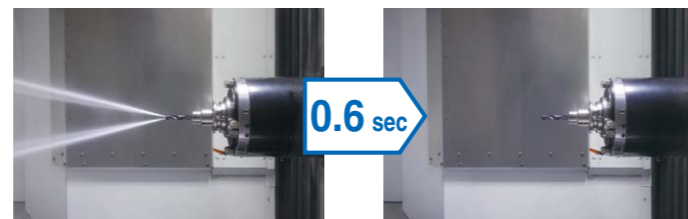

Heavy-duty cutting possible throughout entire machining area

The highly rigid B-axis bearings enhance table rigidity and enable heavy-duty cutting of steel on the upper Y-axis. Highly productive machining is achieved by increasing the number of workpieces to be mounted multiple pieces.



Possible to machine workpiece through holes that exceed the pallet size

It allows through hole machining to a depth greater than the pallet size without flipping the pallet. It reduces cutting time and achieves high-precision machining.

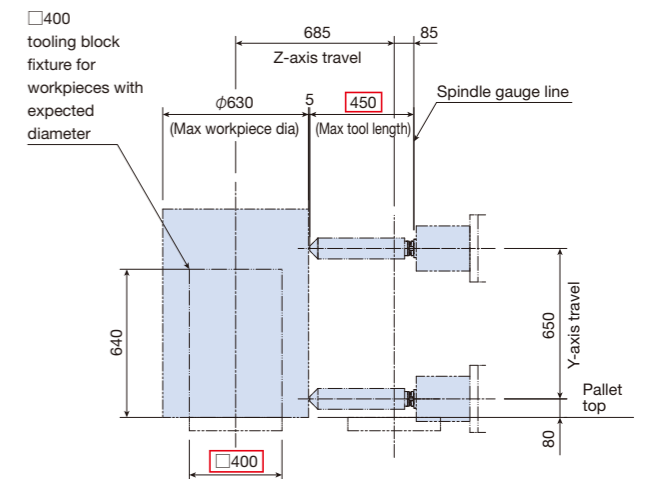

With a small footprint, providing a large machining area

Class smallest installation space

Foot print **11.6 m²**

6% smaller than previous models

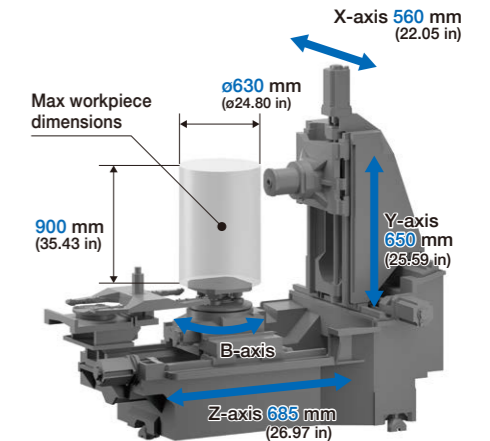

Machining area Compared to previous model

X-axis travel: 560 mm
Y-axis travel: 650 mm 16% expansion
Z-axis travel: 685 mm 10% expansion

Max workpiece dimensions
ø630 x 900 mm (ø24.80 x 35.43) 5% expansion

Note: Standard 2-sided APC specification only

Max tool length
450 mm 50% expansion

Okuma's advanced technology - effective for shop floors

Significantly shortens cycle times and reduces power consumption

Cycle time reduction

- Operation time reduction: The non-cutting time is shortened by simultaneously performing multiple operations, such as spindle rotation and axis feed, and allowing the rotary axis to take the shortest path.
- Machining time shortening: The cycle time is reduced for parts machining with frequent switches between cutting feed and rapid traverse by using feeder-mode high-speed switching and optimal acceleration/deceleration.
- Easy parameter setting: Collects parameters related to cycle time reduction in a single screen for enabling changes and reuse in a single operation.

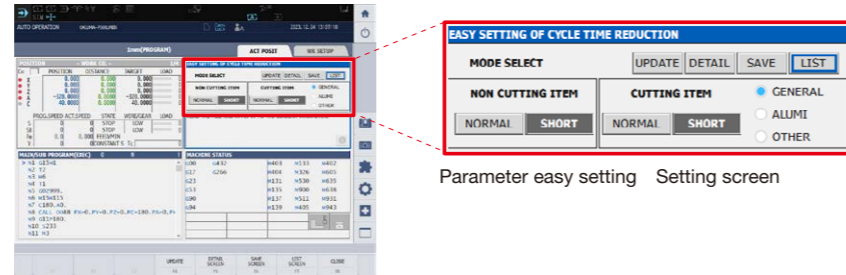

Parameter easy setting Setting screen

Shorter lead times with process-intensive machining

Turn-cut option

Turning operations on machining centers

Simultaneously controlling X-Y circular motion with the tool edge position rotated by the spindle tool enables lathe-like turning.

- Tapers also possible
- Hole making with different diameters — with one tool
- IDs and ODs can be machined when they exceed the maximum tool diameter that ATC can handle

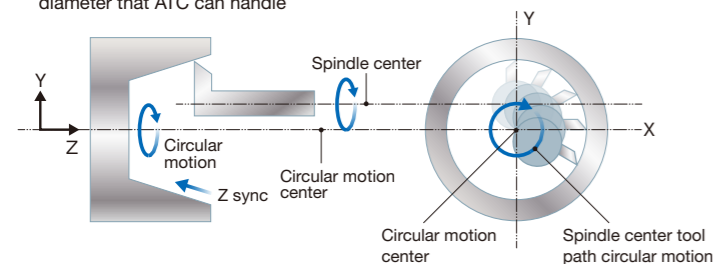

Note: AbsoScale detection and ball-screw cooling required.

Turning valve parts

With Turn-Cut, it's possible to turn the seating surfaces required by gas pipe sealing conditions.



Grooving with high sealability

Flat-Tool Grooving option

Airtight seal grooving

The spindle phase is precisely synchronized with cutting edge motion, to perform highly accurate grooving.

- Getting high sealability without hand finishing.
- Complex seal groove curves also cut with flat tools.



Allowing operators to focus on making parts

Collision Avoidance System option
Collision prevention

CAS prevents collisions in automatic or manual mode, providing risk-free protection for the machine and great confidence for the operator.

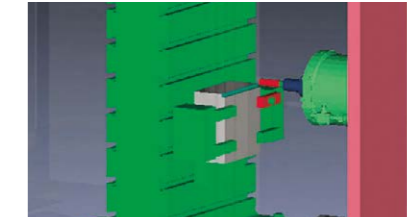

Achieves long term accuracy and surface quality

SERVO NAVI option
Optimized Servo Control

Cycle time shortened with faster acceleration

SERVO NAVI AP (Automatic Parameter setting): Work Weight Auto Setting

On table travel type machining centers, the table feed acceleration with the previous system was the same regardless of weight, such as workpieces and fixtures loaded on the table. Work Weight Auto Setting estimates the weight of the workpiece and fixture on the table and automatically sets the linear axis servo parameters, including acceleration, to the optimum values. Cycle times are shortened with no changes to machining accuracy.

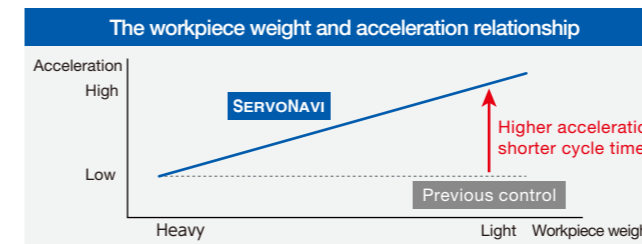

Automatically changes to optimum spindle speed

Machining Navi M-i option
Cutting condition search for milling

Chatter vibration is measured by built-in sensors, and Machining Navi automatically changes spindle speed to the optimum speed.

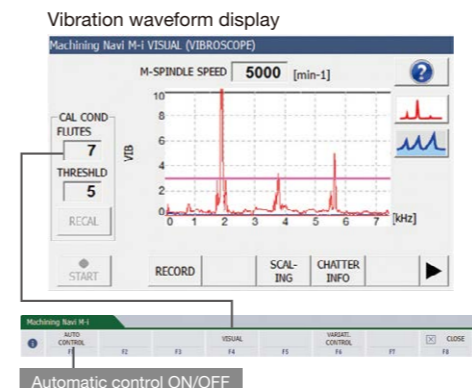

Maintains machining accuracy and surface quality

SERVO NAVI SF (Surface Fine-tuning): Reversal Spike Auto Adjustment

Slide resistance changes with length of time machine tools are utilized, and discrepancies occur with the servo parameters that were the best when the machine was first installed. This may produce crease marks at motion reversals and affect machining accuracy (part surface quality). Reversal Spike Auto Adjustment maintains machining accuracy by switching servo parameters to the optimum values matched to changes in slide resistance.

Contributes to longer machine life

SERVO NAVI SF (Surface Fine-tuning): Vibration Auto Adjustment

When aging changes machine performance, noise, vibration, crease marks, or fish scales may appear. Vibration Auto Adjustment can quickly eliminate noise and vibration even from machines with years of operation.

Adjust cutting conditions while monitoring the data

Machining Navi M-gII+ option
Cutting condition search for milling

Based on the chatter noise captured by the microphone, Machining Navi displays a number of optimal spindle speed possibilities on the screen. The operator can change to the indicated spindle speed with a single touch and immediately confirm the result.

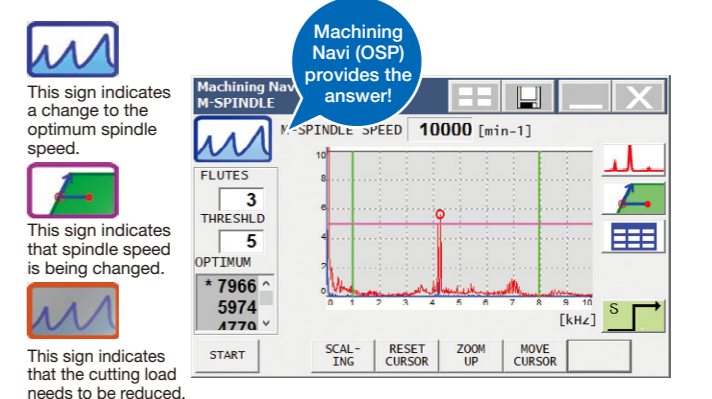

- This sign indicates a change to the optimum spindle speed.
- This sign indicates that spindle speed is being changed.
- This sign indicates that the cutting load needs to be reduced.

Okuma's advanced technology - effective for shop floors

With predictive maintenance, prevent machine stoppages just in time

AI Machine Diagnosis Function
Machine tool diagnostics technology with artificial intelligence (AI) option

Okuma's AI-equipped control detects abnormalities in the machine spindle and feed axes, leading to the prevention of long machine downtime and achieving stable production over a long period of time. The operators themselves can easily diagnose the machine by following simple screen guidelines on the Okuma control.

Notes:
AI diagnostic models are already installed, and diagnoses can be performed by the machine itself.
AI diagnostic models can be updated through Okuma's Connect Plan.
AbsoScale detection specs is required for ball-screw wear detection.

AI Spindle Diagnosis Function

Detects damage to spindle bearings

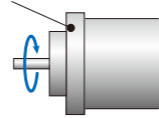

Self-diagnosis of spindle and feed axis status with AI

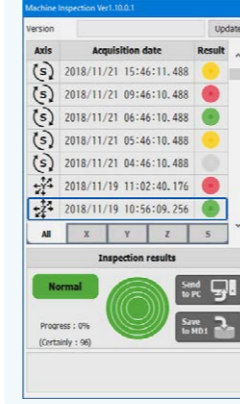

AI Feed Axis Diagnosis Function

Detects damage to ball-screw support bearings

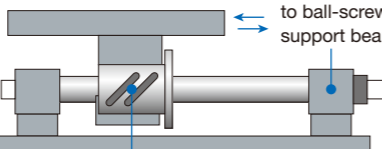

Detects ball-screw wear condition

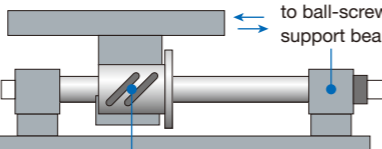

Improving the performance of machining dies and free-form surfaces

Hyper-Surface II option

No modification of NC data is required. By reducing streaks and edge irregularities, machined part quality can be improved and hand finish polishing time can also be reduced. The Hyper-Surface function automatically compensates for edge positioning errors of the machining data output from CAM or the adjacent cutting path while maintaining shape accuracy. In addition, the SMART finish reduces vibration at corners without slowing down, reducing machining time and improving surface quality.

Notes:
Technical consultation is required.
The effect varies depending on the machining shape.

Without function

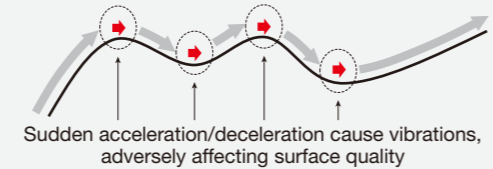

Sudden acceleration/deceleration cause vibrations, adversely affecting surface quality

With function

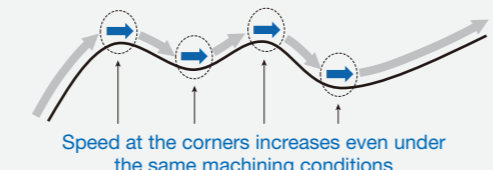

Speed at the corners increases even under the same machining conditions

Manpower-saving solutions that reduce the operator's workload

Coolant maintenance work is significantly reduced
The environmental impact of coolant disposal is also minimized

Sludgeless Tank

The Sludgeless Tank continuously circulates cutting fluid within the tank, efficiently collecting sludge to prevent accumulation and significantly reducing issues and maintenance work. This significantly reduces the frequency of tank cleaning, enabling stable operation over long periods and improving productivity. It also extends the cutting fluid's lifespan, helps prevent spoilage and odors, and creates a better working environment. Furthermore, reducing the frequency of cutting fluid changes decreases industrial waste and lessens the environmental impact.

Sludge removal rate 99% (when the material is casting and aluminum)
Notes: After secondary filtration (cyclone filter) permeation Okuma evaluated removal rate

No coolant tank cleaning required for 3 years
(Okuma equipment actual data)

No coolant replacement required for 3 years
(Okuma equipment actual data)

Note:
It is necessary to select a chip conveyor with drum filter if the Sludgeless Tank option is chosen.

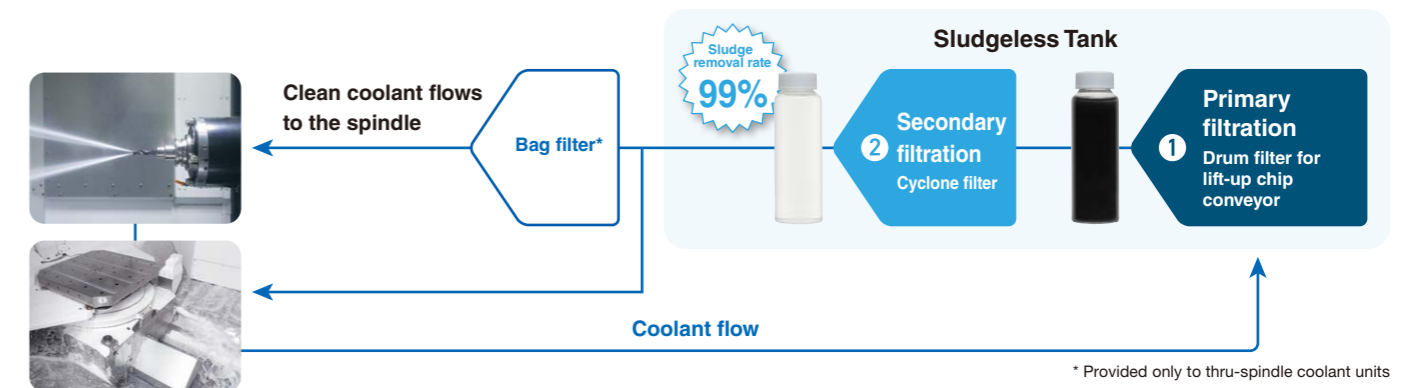
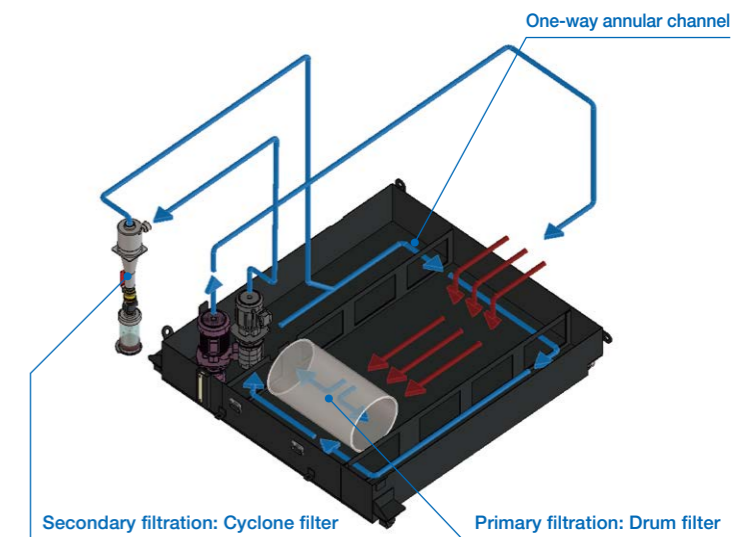

Keeping spindle tapers clean

The three filtration devices in the Sludgeless Tank and coolant suction inside the spindle reduce dirt on the spindle taper and lessen defective machining.

Note: Suction of coolant from the spindle also limits the outflow of coolant to the spindle taper when changing tools.

Adopting a compact separate thru-spindle coolant unit

The thru-spindle coolant tank has been made compact and space-saving is achieved even though it is installed separately.



Flexible production for high-mix workpiece applications, with automated machining over

long periods

Flexible automation support

Significantly increased number of pallet-through jig ports option

The setup station pallet base can be equipped with up to 16 fixture ports for hydraulic and pneumatic pressure, and the machining chamber table base can have up to 8 ports for flexible automation applications. Hydraulic circuits that tend to be complicated can be simplified, and auto-clamp fixture designing becomes easy. Customers benefit from more freedom in systemizing and in meeting more diverse automation needs.

Setup station

Max **16 ports** (hyd/pneu)^{*1*2}

For the setup station 16 port preps

With 16 ports, arrangements for robotic and automation applications will be expanded, and more flexible fixture support will be possible. With 16 ports, a large number of parts can be mounted, and a different workpiece can be clamped on each side of a 4-sided tooling block fixture.

*1. 8 or 16 ports available.
(for 16 ports, max 12 hydraulic ports)
*2. Hydraulic pressure: 7 MPa.

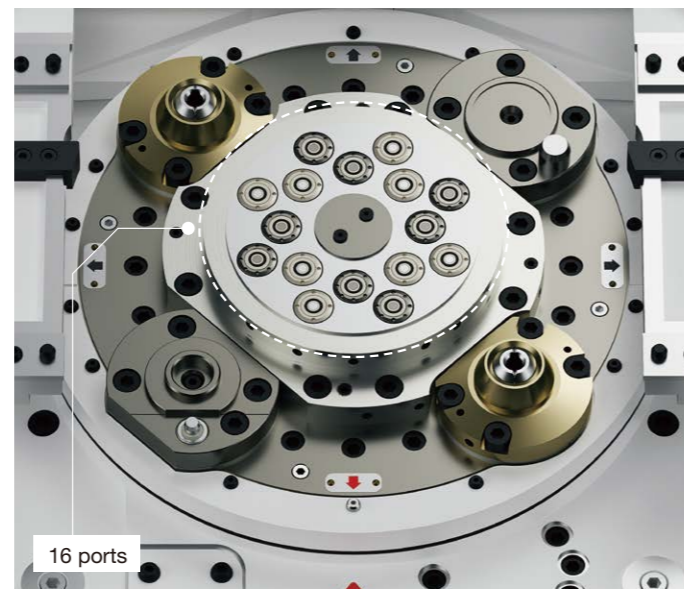

Machining chamber (table)

Part load/unload^{*1}

Max **7 ports**^{*3}

Workholding clamps^{*2}

Max **8 ports**^{*3}

Part load/unload in machining chamber (table) also possible

"Part load/unload" jig ports also allow part load/unload in the machining chamber. Adjustment times for trial cuts can be shortened and fixture readjustments in the machining chamber improve work efficiency. With more ports, hydraulic applications have increased, eliminating complicated hydraulic circuits arrangements.

*1. For part load/unload in the machining chamber, select part load/unload.
*2. If the above is not required, select workholding clamps.
*3. Hydraulic pressure: 7 MPa.



Combining automation setup with robots to further improve productivity

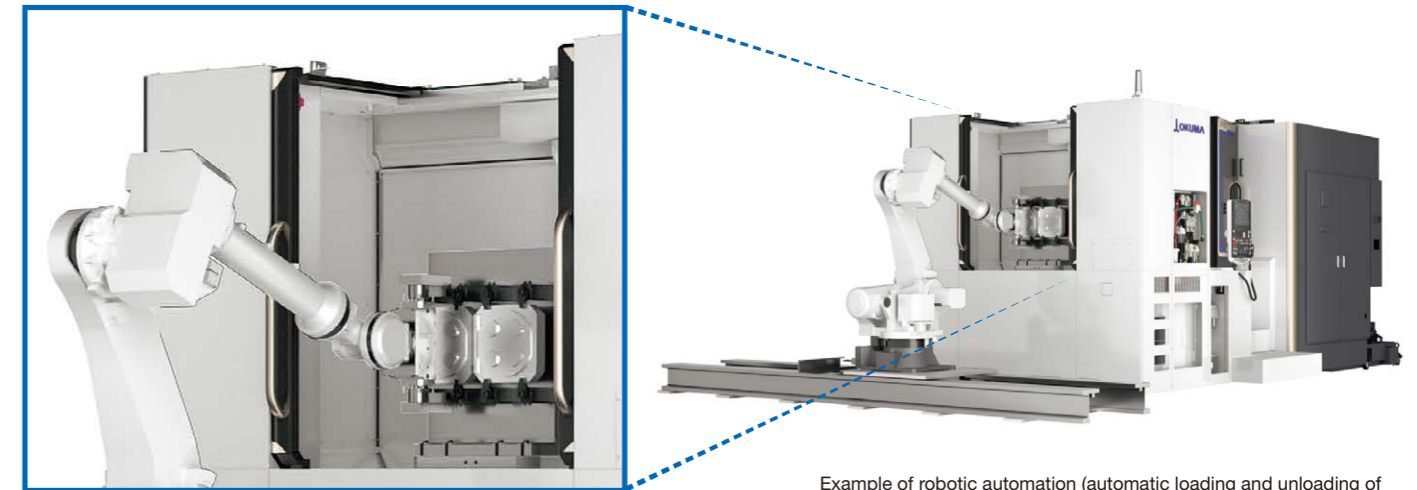

Auto Setup Station Pallet Rotate option

This feature automatically rotates the setup station pallet in 90° increments by stepping on the foot switch. Operator efficiency has been improved, and robotic part load/unload* can be done from multiple fixtures.

* Only two-pallet pivoted APC is supported.



Expandability of tool magazine

Respond flexibly with magazine matched to needed tool storage capacity.

Space-saving with large tool capacity

Standard	Disc system	48 tools
Optional	Disc system	64 tools
Specifications	Matrix system	140, 180, 220, 260, 300, 340 tools



Disk system ATC magazine (64 tools: option)

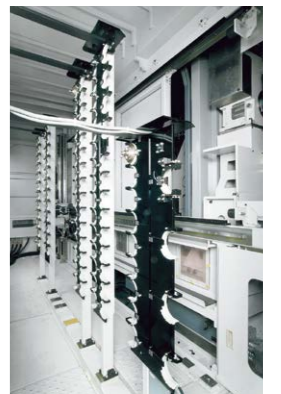

Matrix system ATC Magazine (option)

Ease of use with consideration of harmony between people and machines



1 Setup station with wide door opening to facilitate easy operation. Heavy workpieces can be delivered with a crane

Wide opening for easy loading and unloading of workpieces

- More efficient setups



Open ceiling for both setup station and machining chamber (with door open)
Easy transportation of heavy workpieces by crane

- Easy part load/unload by crane
- Lighting is good, and coolant doesn't drop in the machining chamber



Setup station

Machining chamber

2 OSP-P500 operation panel with excellent operability and visibility

Operation panel mounted on the left for visibility and operability by swivel movement

- Workpiece and operation screen X-Y-Z directions are the same
- The panel swivels for an easy visual check of the inside of the machine
- The angle can be adjusted to suit the body height of the operator



It can be swiveled according to the working position, ensuring good operability

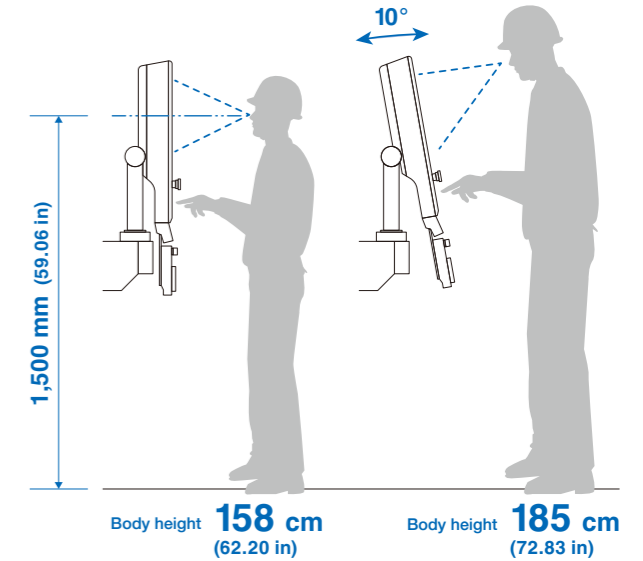

The angle can be adjusted to suit the body height of the operator

3 Good accessibility to the spindle and workpiece

- 440 mm (17.32 in) from tool load/unload button to spindle



Tool load/unload button

4 The workflow is minimized by gathering daily inspection equipment on the operator side. Maintenance is improved



Air equipment

Spindle cooler

Lubrication unit

Stable operation

Chip troubles are eliminated to maintain stable operation

The use of the machine on the actual shop floor is considered. It has a high chip

Improves chip discharge functionality while achieving decarbonization and energy saving

The angle of the internal cover has been increased, and a full center trough mechanism enables chips to be discharged from anywhere with the machining chamber. This greatly improves chip discharge functionality. It reduces the power consumption of coolant pumps by suppressing chip accumulation in an environmentally friendly manner without the use of large amounts of cleaning coolant. With the smooth discharge of chips, the frequency of cleaning inside the machine can be reduced, which also eases the workload of the operator.

Prevents of chips from accumulating in the machine

The slope of the machine cover under the ATC shutter has been increased to prevent the accumulation of chips.



over long hours

discharge capacity that matches its high machining capacity

Full center trough enables chips to be discharged from anywhere with the machining chamber

- All areas of the machining chamber converge with the in-machine chip conveyor. It prevents chip accumulation in the machine chamber.
- Larger directly-below-spindle discharge port. Smoother out-machine chip discharge possible.



Flat cover construction inside the machining chamber

- Preventing chip accumulation with smooth X-, Y-axis telescopic covers and Z-axis stainless steel single cover.
- Flat machining chamber with cleaning pipes and an embedded in-machine lamp.



Preventing chip accumulation in the setup station

Extends the in-machine chip conveyor directly below the APC swing section to ensure the slope angle. Chips directly enter the flushing gutter on both sides of the setup station, and the chips are discharged into the machining chamber.

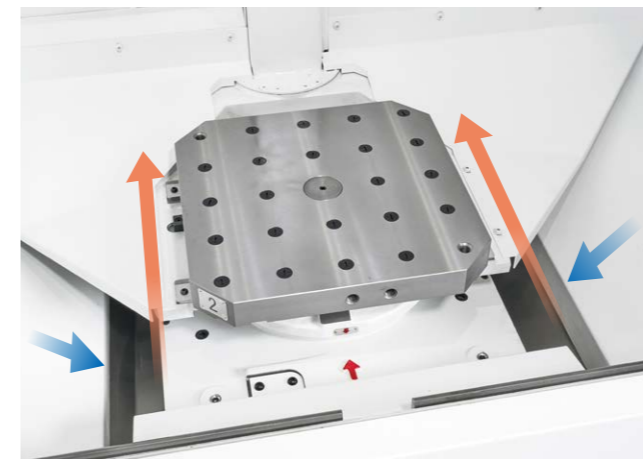

Chip discharge

Optional lift-up chip conveyor that discharges chips to the outside of the machine, and a Sludgeless Tank (recommended option) that efficiently removes sludge are available.

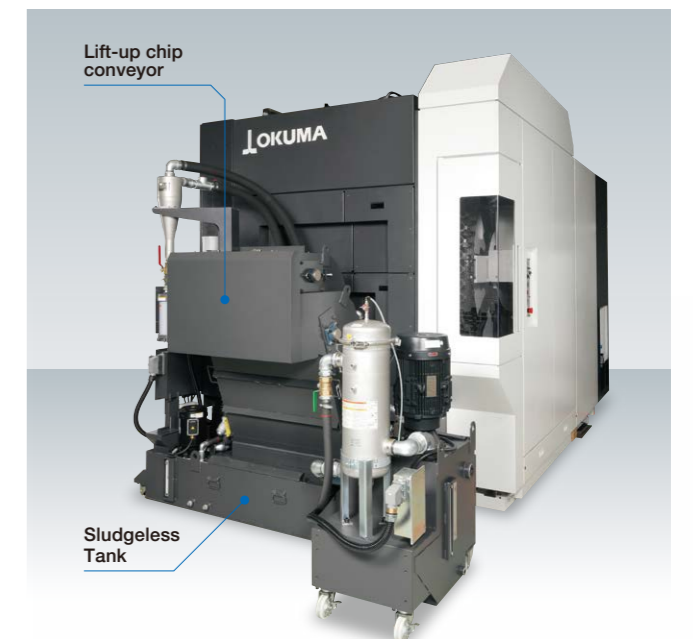

Note: When a Sludgeless Tank is selected, a lift-up chip conveyor (recommended option) with hinges + scraper (with drum filter) is selected.

A next-generation CNC that makes customer manufacturing DX (digital transformation) a reality

OSP-P500

Improved productivity and stable production

As Your Single Source for M-E-I-K (Mechanics - Electronics - IT - Knowledge) merging technologies, Okuma offers this CNC to build an advanced "digital twin" that faithfully reproduces machine control and machining operations and creates new value. In addition, the product helps improve productivity and realize stable production, featuring ease of use that allows customers to use their machining know-how. Additional features are: control technology that achieves high-speed and high-accuracy machining, energy-saving solutions that achieve both high accuracy/productivity and eco-friendliness, and robust security functions to protect against the increasing threat of cyber attacks.

15-inch operation panel



- 1 Faithful digital reproduction of machines and processes
 - | Ground-breaking concept of a digital twin
- 2 Novice-friendly smart operation
 - | Innovative operability
- 3 Realizing high-speed and high-accuracy machining
 - | Revolutionary control technology
- 4 Reducing environmental impact
 - | Energy-saving solutions
 - | **ECO suite plus**
- 5 Increasing cyber resilience
 - | Robust security



Home screen



Virtual machining

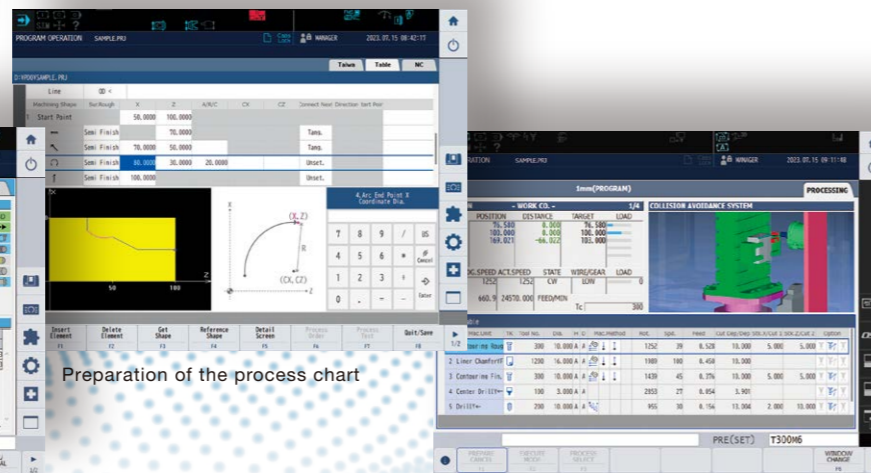

Preparation of the process chart

Operation with the process chart

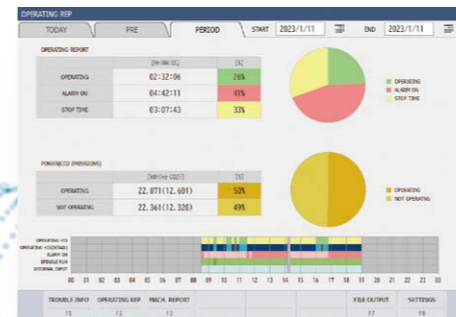

MacMan plus

OSP-P500 A next-generation CNC that makes customer manufacturing DX (digital

1 Faithful digital reproduction of machines and processes

Digital Twin option

Ground-breaking concept of a digital twin

The digital twin calculates cycle time, machining shape, and electricity consumption through super high-speed and high-accuracy simulation. It supports accurate estimates of cycle time, development of the machining schedule, and quick and accurate estimates of delivery time and costs when an order is received.

Simulation using the latest machine information can be achieved even with an office PC or with the built-in OSP-P500. This enables preparation for machining in advance in the office environment (front loading).

Physical machine preparation time can be reduced by using digital twin preparation results to prepare for machining the next parts while machining continues. When a problem occurs on the shop floor, it can be solved quickly on site without going back to the office.

Okuma's 2 digital twin systems

Front loading

Reducing work on the physical machine to increase the operating rate

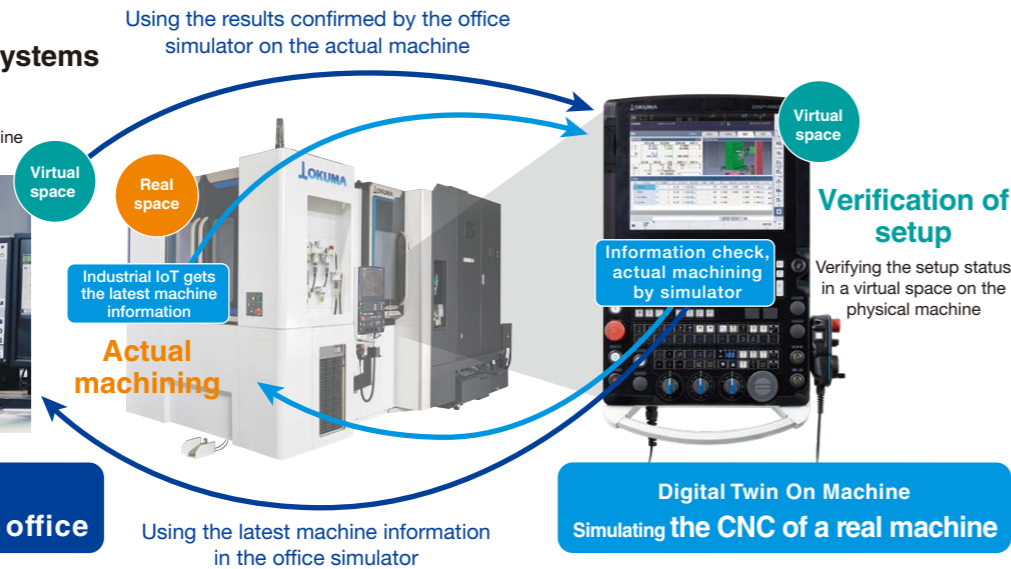

Digital Twin On PC
Simulate shop machines in the office

Front loading is performed with the actual status matched with the data on the office PC to further improve productivity. Highly accurate pre-verification minimizes trial and error in first part machining, and reduces machine downtime to the minimum.

Using the latest machine information in the office simulator

Digital Twin On Machine
Simulating the CNC of a real machine

Super-fast and super-accurate machining simulations are performed with the CNC of a real machine on-site to minimize machining preparation work. Actual machining can be started immediately, greatly improving the operating rate of the machine.
Note: The screens above are examples of the Collision Avoidance System (option).

2 Novice-friendly smart operation

Smart OSP Operation option

Innovative operability

Conventionally, machining operations are programmed with G-/M-code based on drawings. With OSP-P500, however, you only have to follow the guidance to enter drawing information. So you can prepare for machining quickly, even if you have no familiarity at all with the NC program language.

■ Operation without reliance on G-/M-codes enables easy, quick machining by anyone

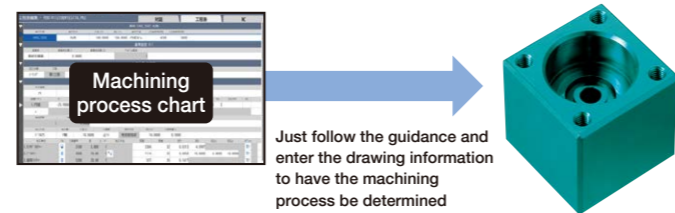

■ High-productivity programs are easy to create

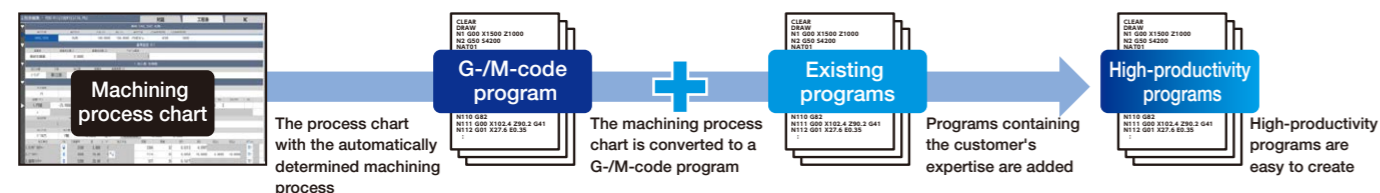

transformation) a reality

3 Realizing high-speed and high-accuracy machining

Revolutionary control technology

CNC operation performance has been doubled compared to the conventional model (OSP-P300A). The processing capacity and the response speed between control modules have been improved to shorten the machining time. The time for machining general parts can be shortened if the machining program and machining conditions are the same as before.

4 Reducing environmental impact Energy-saving solutions

ECO suite plus

"ECO suite plus" features the functions ECO Idling Stop, which allows the device to autonomously judge and shut down unnecessary auxiliary equipment, ECO Power Monitor, which gives visibility to carbon dioxide emissions, enabling these to be recorded and analyzed, and ECO Operation, which enables the optimized operation of peripheral equipment during machining.

This is an energy-saving system that achieves both high accuracy, high productivity, and environmental friendliness to support improvement cycles for decarbonization.

For details, please refer to P24.

5 Protecting the operation of machines and precious assets such as part programs from cyber attacks

Robust security that increases cyber resilience

As digital networks develop and servers are increasingly connected to factory machines, the threat of cyber attacks increases, making it ever more important to protect against them. OSP-P500 is equipped with robust security functions for defense against and protection from cyber attacks, along with data restoration, to protect the operation of machines and precious assets such as part programs in the event of a cyber attack.



Defense	Prevent unauthorized access and connection	Identification of operators and communications, authentication function, etc.
Protection	Control damage	Anti-virus measures based on the allowlist, functions to prevent falsification and detect abnormalities, etc.
Data restoration	Preparation for emergencies	Control software and data backup function, etc.

OSP-VPSII (Virus Protection System II)

OSP-VPSII (Virus Protection System II) incorporates allowlisting*1 antivirus functions into the Okuma CNC (OSP) to prevent infection by viruses via networks and USB devices.

■ **OSP-VPSII-STD**

OSP-VPSII-STD [Standard] includes antivirus functions developed exclusively for Okuma's numerically controlled machines. Machines can be used safely, as only software tested by Okuma can be run.

Note: Because the allowlist is locked, only Okuma software can be run.

■ **OSP-VPSII-EX (option)**

OSP-VPSII-EX [Expert] includes antivirus functions made by TXOne Networks*2. The allowlist can be edited by the customer, so any software can be installed*3.

Note: Incorrectly editing the allowlist may prevent OSP from operating normally, so specialized knowledge of allowlisting antivirus functions is required.

*1. Allowlisting is a method in which safe software is listed and software not included in the list is prevented from running.
*2. TXOne Networks is a registered trademark of TXOne Networks Inc.
*3. This does not guarantee the operation of any software on OSP. Note that installed software may prevent OSP from operating properly.

Energy-saving technology

It contributes to providing both high productivity and high precision while being eco-friendly

Achieving high accuracy and high productivity while achieving decarbonization and energy saving



Okuma has worked to reduce energy consumption in order to achieve carbon neutrality at the three factories in Japan which are our main production bases. We have realized high productivity through automation and process-intensive machining, in addition to high-accuracy machining, and we then introduced the use of green energy to transform the three domestic factories into carbon-neutral factories. "Green-Smart Machines" is our definition of Okuma's intelligent machine tools, which autonomously achieve stable dimensional accuracy and reduced energy consumption, to support environmentally friendly production. Our policy is to deploy "Green-Smart Machines" fully, to help achieve a carbon-free society. Starting with products manufactured at those carbon-neutral factories and supplying them all over the world, we will work together with our customers to help solve the social issues faced by the manufacturing industry.

Green-Smart Machines are **environmentally friendly** products that autonomously achieve stable dimensional accuracies and reduced energy consumption.

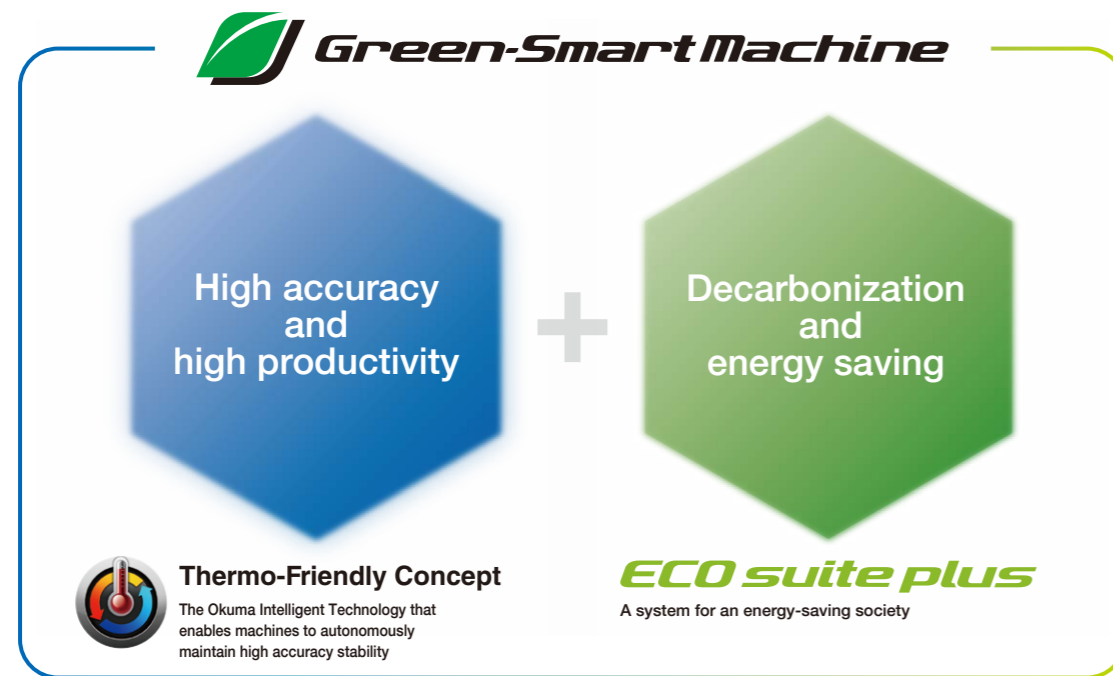

The Okuma Intelligent Technology that enables machines to autonomously maintain high accuracy stability



The unique concept of accepting temperature changes achieves consistent high accuracy without special coolers or excessive air conditioning.

- Reduction of warm-ups and dimensional compensation**
Reduce the time needed for daily warm-ups and dimensional compensation to adjust to ambient temperature changes.
- Reduction of power used for air conditioning**
Maintain high stability of dimensional accuracy even if the air conditioning temperature range is expanded.
- Reduction of machine body coolers**
Achieve outstanding dimensional accuracy without any special machine body cooling being required to maintain accuracy.

The Okuma way to cool

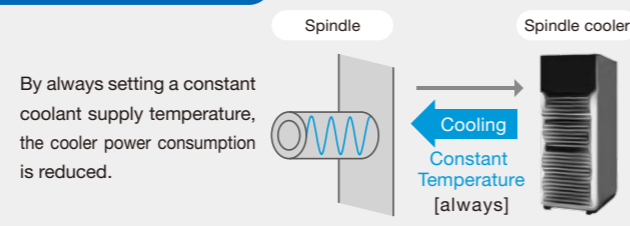

A system for an energy-saving society

ECO suite plus

The "ECO suite plus" retains the concept of achieving both high machining accuracy stability and energy savings (less carbon dioxide emissions) achieved by the Thermo-Friendly Concept and the "ECO suite" that was put into practical use in 2014. It is an energy-saving system with enhanced high-accuracy/-productive functionality and advanced eco-friendly support.

Actively turn off unnecessary peripherals

ECO Idling Stop

All auxiliary equipment when not needed (most of factory power consumption), can be turned off. The ECO Idling Stop button enables diligent idle stop operations even during machining and maintenance work. With ECO suite plus, the machine automatically detects the operating status, eliminating the need to push buttons while reducing carbon dioxide emission as much as possible without operator awareness.

Peripheral equipment runs only when needed

ECO Operation

By using only the required peripherals (chip conveyors, mist collectors, etc.), energy-saving operations that also maintain high productivity are possible. ECO suite plus enables more detailed tuning of operations to thoroughly support carbon dioxide emission reduction activities that do not reduce productivity.

ECO PARAMETER	ECO IDLE STOP (min)	ECO OPERATION
ECO IDLE STOP ELAPSED TIME	000:00:00	REPAIRING TIME UNTIL ECO IDLE STOP READY 12:48
Chip conveyor interval control	OFF	UNIT
Chip conveyor interval active time	100	[min]
Chip conveyor interval suspended time	200	[min]

Confirming energy savings and analyzing reductions

ECO Power Monitor

Making it possible for the OSP control to analyze the operating status of each device.

The decarbonization cycle on the shop floor is supported through the three phases, 1. View, 2. Record, and 3. Analyze.

1 Check carbon dioxide emissions on the spot

With ECO suite plus, you can also check the power consumption of each device.

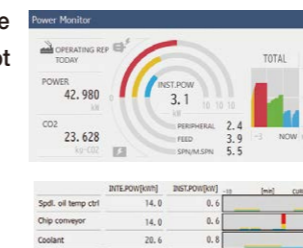

2 Simultaneously records operating status and carbon dioxide emissions

With ECO suite plus, recording carbon dioxide emissions for each device, and data output is possible.

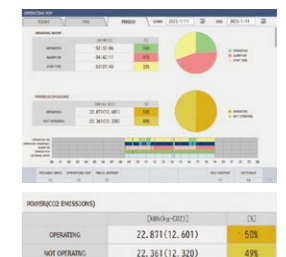

3 Analyze carbon dioxide emissions and improve machine tool operation

With ECO suite plus, not only the display on the machine but data analysis for each device is also possible on a PC, to see a more detailed carbon dioxide emission analysis.

Example of utilizing One-Touch Spreadsheet (option) to create visual feedback of machine's power consumption and carbon dioxide emissions.

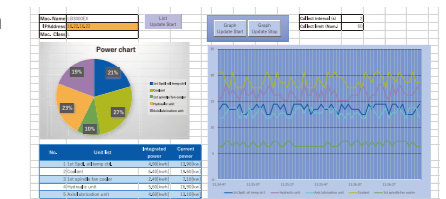

Energy-saving solutions that reduce environmental impact

Energy-saving hydraulic unit

By adopting an intermittent-operation-type hydraulic unit equipped with an accumulator and non-leak valve,

the power consumption of the hydraulic unit has been reduced by **90%*** compared to the previous model

* The calculation conditions are 10 times ATC, 10 times B-axis indexing, and 2 times APC in 10 minutes

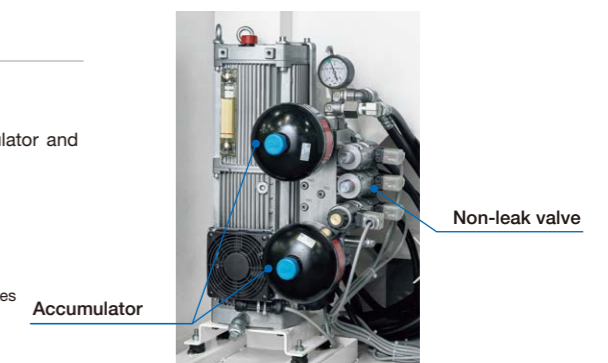

Machine Specifications

		MA-4000H	
Travels	X-axis (column left/right)	mm (in)	560 (22.05)
	Y-axis (spindle up/down)	mm (in)	650 (25.59)
	Z-axis (table front/back)	mm (in)	685 (26.97)
	Spindle center to pallet top	mm (in)	80 to 730 (3.15 to 28.74)
	Spindle nose to pallet center	mm (in)	85 to 770 (3.35 to 30.31)
Pallet	Pallet size	mm (in)	400 × 400 (15.75 × 15.75)
	Max load capacity	kg (lb)	400 (880)
	Indexing angle	deg	0.001
	Max workpiece dimensions	mm (in)	ø630 × 900 (ø24.80 × 35.43)
Spindle	Speed	min ⁻¹	15,000 [12,000, 20,000]
	Tapered bore		7/24 taper No. 40 [HSK-A63] ^{*1}
	Bearing dia	mm (in)	ø70 (ø2.76) [ø90 (ø3.54)]
Feed rate	Rapid traverse	m/min (ipm)	X, Y, Z: 60 (2,362)
	Cutting feed rate	mm/min (ipm)	X, Y, Z: 1 to 60,000 (0.04 to 2,362)
Motors	Spindle		38/18.5 (51/25)
		kW (hp)	[12,000 min ⁻¹ : 38/26 (51/35) <40%ED/cont>] [20,000 min ⁻¹ : 43/22 (58/30) <15%ED/cont>]
	Feed axes	kW (hp)	X: 5.2 (7) Y, Z: 4.6 (6)
	Table indexing	kW (hp)	3.0 (4)
Auto tool changer (ATC)	Tool shank		MAS403 BT40 [CAT40, DIN40, HSK-A63] ^{*1}
	Pull stud		MAS2 [MAS1, CAT, DIN, JIS]
	Magazine capacity	tools	48 ^{*2} [64] ^{*2} [140, 180, 220, 260, 300, 340] ^{*3}
	Max tool dia (w/ adjacent)	mm (in)	ø90 (ø3.54)
	Max tool dia (w/o adjacent)	mm (in)	ø170 (ø6.69)
	Max tool length	mm (in)	450 (17.72)
	Max tool mass	kg (lb)	12 (26.4)
Tool selection		Memory random [fixed address] ^{*4}	
Machine Size	Height	mm (in)	2,750 (108.27)
	Floor space; width × depth (RDF specs) ^{*5}	mm (in)	2,300 × 5,065 (90.55 × 199.41)
	Mass	kg (lb)	11,000 (24,200)
Controller			OSP-P500M

[] : option
^{*1}. 20,000 min⁻¹ with HSK-A63 only
^{*2}. Disk magazine
^{*3}. Matrix magazine
^{*4}. Matrix magazine types use the fixed address
^{*5}. With RDF drum filter-type lift-up chip conveyor

Standard Specifications & Accessories

Spindle speed	15,000 min ⁻¹ , 38/18.5 kW (51/25 hp) <40%ED/cont>	Air filter and oiler	
ATC magazine capacity	48 tools	Energy-saving hydraulic unit	Pressure-accumulated intermittent operation type
Spindle cooler	Oil temperature controller	Automatic 0.001° indexing table	NC table
Centralized lubricant	Grease cartridge 700 ml, and with automatic oil supplier	2-pallet swing-shuttle APC	Pallet top surface M16 tap
Coolant system	Tank 800 L (effective: 710 L) Pump 0.55/0.75 kW (50/60 Hz)	Full enclosure shielding	Two-pallet pivoted type for APC
In-machine chip discharge	Hinge type chip conveyor	ATC operation panel	
Thru-spindle coolant*	1.5 MPa	Status indicator	3 phase C type Red (alarm), Yellow (end), Green (running)
Suction of excess coolant in spindle		Work lamp	LED lamp
Shower coolant systems	8-nozzle type	Foundation washers, jack bolts	
ATC air blower (blast)		Tool release lever	
Chip air blower (blast)	Nozzle type	Tapered bore cleaning bar	
Sludgeless Tank		Hand tools	
In-machine chip washer		TAS-S (Thermo Active Stabilizer–Spindle)	
Below pallet washing		TAS-C (Thermo Active Stabilizer–Construction)	

* Okuma pull stud required with thru-spindle coolant.

Optional Specifications & Accessories



Spindle speeds	12,000 min ⁻¹ , 38/26 kW (51/35 hp) <40%ED/cont> * See P8 for details 20,000 min ⁻¹ , 43/22 kW (58/30 hp) <15%ED/cont>
Dual contact spindle ^{*1}	HSK, BIG-PLUS®
ATC magazine capacity	64 (disk magazine) 140, 180, 220, 260, 300, 340 (matrix magazine)
AbsoScale detection	X-Y-Z axes
Pallet top	T-slots, inch holes
Spare pallets	
Edge locator	
Oil-hole coolant system	1.5 MPa
Thru-spindle coolant ^{*2}	7.0 MPa; Large flow 1.5, 7.0 MPa
Workpiece wash gun	
Oil mist lubricator	

Chip air blower (blast)	Adapter
Off-machine chip discharge (lift-up chip conveyor types)	· Hinge type · Scraper type * See the table below for details · Hinge + scraper type
Chip buckets for above	
Coolant heater/cooler	
Tool breakage detection	Auto tool length compensation included (touch sensor)
In-magazine tool breakage detection	
Auto zero offset	Auto gauging (touch probe)
Tool life management	By cumulative operation timer, etc
Pull stud bolt shape	MAS1, CAT, DIN, JIS
Standard T-column fixture	Height: 640 mm, Width: 400 mm, T-slot pitch: 80 mm
Standard square-column fixture	Height: 640 mm, Width: 270 mm, T-slot pitch: 80 mm
Ball-screw cooler	X-Y-Z axes

^{*1}. Be sure to select this specification when BIG-PLUS® holder is used.
^{*2}. Okuma pull stud required with thru-spindle coolant.

Recommended chip conveyors (Please contact an Okuma sales representative for details.)

○ : Recommended △ : Conditionally recommended

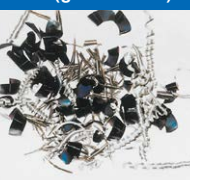
Work piece material	Steel	Cast iron	Aluminum / non-ferrous metal	Mixed (general use)
Chip shape				
In-machine chip discharge	Hinge type (standard) ^{*1}	○	○	○
Off-machine chip discharge (option) ^{*2}	Hinge + scraper with drum filter ^{*3} (recommended)	○	○	○
	Hinge type	○	—	—
	Scraper type ^{*4}	—	○ (dry)	—
	Scraper type with drum filter	—	○ (wet) with magnet	△ ^{*4}

^{*1}. Scraper type (option) can be selected. ^{*2}. With limitations per conveyor discharge direction.
^{*3}. This type will be selected when the Sludgeless Tank has been selected. ^{*4}. When chips are shorter than 100 mm

Off-machine lift-up chip conveyors

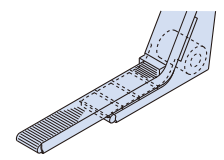
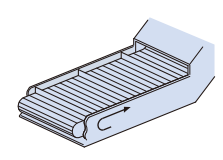
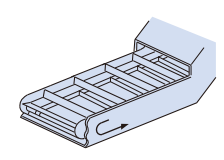
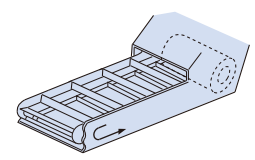
Type	Hinge + scraper with drum filter	Hinge	Scraper	Scraper with drum filter
Shape				

Note: Becomes hinge + scraper with drum filter if Sludgeless Tank (option) is selected.

Standard Specifications

Basic Specs	Control	X, Y, Z, simultaneous 3-axis, spindle control (1 axis)
	Position feedback	OSP full range absolute position feedback (zero point return not required)
	Coordinate functions	Work coordinate system (20 sets)
	Min / Max command	±99999.999 mm, ±9999.9999° 8-digit decimal, command units: 0.001 mm, 0.01 mm, 1 mm, 0.0001°, 0.001°, 0.01°, 1°
	Feed override	Cutting feed override 0 to 200%, rapid traverse override 0 to 100%
	Spindle override	Override 30 to 300%
	Tool information management	Compensation, life management, shape data, etc. are collectively managed for each tool (999 tools can be registered)
	Tool compensation	Tool length compensation / tool radius compensation 3 sets for each of the registered tools (up to 999 tools), maximum number of total sets: 999
	Operation panel	15-inch operation panel (15-inch XGA screen + multi-touch panel operations), Operation panel tilt adjustment, portable pulse handle (type A), Keyboard QWERTY layout, window operation that is optimal on machine shops
	Security	Operator authentication, lock screen, OSP-VPSII-STD
Machining programming	Program capacity	Program storage: 4 GB, operation buffer: 2 MB
	Programming	Program editing, file name index display, scheduled programs, Hole drilling fixed cycles (drill, deep bore drill, high-speed deep bore drill cycles, etc.), combined use of mm/min, keyway cycle, Coordinate calculation, area machining, coordinate change (shift, rotation and copying of the workpiece coordinate), Block skip (1 set), User Task (GOTO statement, IF statement, arithmetic operations, IF/THEN, DO/WHILE, GOTO (variables) statement, etc., functional operations, logic statements, inverse trigonometric functions, Common variables (std: 200 sets), local variables, system variables, sub-programs, G-/M-code macros (G-code: 20 sets, M-code: 20 sets), READ/WRITE/GET/PUT), basic interpolation, circular radius designate, taper angle designate, NCYL command, home position, Program operation type (A-Operation, B-Operation, S-Operation), oriented spindle stop, programming help
Operations	OSP suite	Various "suite" apps support the series of machining operations, and "suite operation" enables one-touch access to those apps
	Easy Operation	"Single-mode operation" to complete a series of operations, "Setup data" to set the zero point easily using the measuring function (option)
	Operations	Manual cutting feed, sequence return, sequence number search, manual interrupt & auto return, MDI input, Pulse handle overlap, Library programs, parameter I/O, relative actual position display, PLC monitor, operation help, Alarm help, Continued operation at the time of temporary power failure
Monitoring, Adaptive control		Real 2D display, load meter display, maintenance monitor, collection of log data for maintenance, SERVONAVI AP, SERVONAVI SF, rotary axis notch filter switch, local variables display, display of remaining machining time
MacMan plus		Aggregation and display of machining records, operating records, operating history and trouble information, Visualization of power consumption, Records, output of records and trouble info file
Automation/Unattended operation		Auto power shutoff
Communications/Networks		USB3.0 interface (2 ports), Ethernet interface, DNC-T1, Smart I/F (Connect Plan interface), browser
High-Speed/		Hi-G control, Hi-Cut Pro, pitch error compensation, TAS-S (Thermo Active Stabilizer–Spindle),
High-Accuracy Functions		TAS-C (Thermo Active Stabilizer–Construction), cycle time reduction (operation time reduction, machining time reduction, easy parameter setting), in-position check, exact stop check, variable lost motion compensation
Energy-saving functions	ECO suite plus	ECO Idling Stop, ECO Operation, oil temperature controller auto control, ECO Power Monitor*1
	Power Regeneration System	Regenerative power is used when the spindle and feed axes decelerate to reduce energy waste

*1. The displayed power is an approximate value. If you need an accurate power value, please select the option to attach a wattmeter.

Kit Specifications

		NML		OT-IGF		Digital Twin				Digital Twin OT-IGF			
		E	D	E	D	E	D	VE	VD	E	D	VE	VD
Interactive functions	Advanced One-Touch IGF-M (including real 3-D simulation)			●	●					●	●	●	●
	Interactive MAP (I-MAP)					●	●	●	●				
	Smart OSP Operation			●	●	●	●	●	●	●	●	●	●
	Machining process chart preparation and operation			●	●	●	●	●	●	●	●	●	●
High-Speed/High-Accuracy Functions	Dynamic displacement compensation	●	●	●	●	●	●	●	●	●	●	●	●
Digital Twin On Machine	Virtual Machining					●	●	●	●	●	●	●	●
	Quick modeling					●	●	●	●	●	●	●	●
	OPC UA for Machine Tools					●	●	●	●	●	●	●	●
	OSP API KIT					●	●	●	●	●	●	●	●
Digital Twin On PC	Virtual Machining							●	●			●	●
	Quick modeling							●	●			●	●
Programming Machining Operations	Operation buffer 10 MB	●	●	●	●	●	●	●	●	●	●	●	●
	Program notes	●	●	●	●	●	●	●	●	●	●	●	●
	Coordinate system selection	●		●		●		●		●		●	
	(Std: 20 sets)			●		●		●		●		●	
	Helical cutting (within 360°)	●	●	●	●	●	●	●	●	●	●	●	●
	Synchronized Tapping II	●	●	●	●	●	●	●	●	●	●	●	●
	Arbitrary angle chamfering	●	●	●	●	●	●	●	●	●	●	●	●
	Programmable travel limits	●	●	●	●	●	●	●	●	●	●	●	●
	Coordinate change and drawing conversion			●		●		●		●		●	
	Enlarge/reduce			●		●		●		●		●	
Sequence stop	●	●	●	●	●	●	●	●	●	●	●	●	
Sequence return			●		●		●		●		●		
Auto scheduled program update	●	●	●	●	●	●	●	●	●	●	●	●	
Tool management	Tool wear compensation	●	●	●	●	●	●	●	●	●	●	●	●
	Tool wear compensation input restriction	●	●	●	●	●	●	●	●	●	●	●	●
	Tool life management (including prior notice, warning, and special prior notice/warning)	●	●	●	●	●	●	●	●	●	●	●	●
Monitoring	Real 3-D Simulation			●	●	●	●	●	●	●	●	●	●
	Simple load monitor	●	●	●	●	●	●	●	●	●	●	●	●
	NC operation monitor (counter, totaling)	●	●	●	●	●	●	●	●	●	●	●	●
	Tool breakage no-load detection			●		●		●		●		●	
Measuring	Manual measuring (not including sensors)	●	●	●	●	●	●	●	●	●	●	●	

Notes. NML: Normal, OT-IGF: One-Touch IGF, E: Economy, D: Deluxe, VE: Virtual Economy, VD: Virtual Deluxe. For each specification, please refer to Optional Specifications in P29 and P30.

Optional Specifications

Operation panel	Monitor, operation panel	21.5-inch operation panel 21.5-inch Full HD touch screen
	Pulse handle	Portable pulse handle with function buttons (Type B1) Pulse handle with touch panel Pulse handle addition (3 pieces in total)
	Keyboard	Keyboard ABC layout
Interactive functions	Advanced One-Touch IGF-M	Auto operation decision (drilling, milling) A variety of machining including contouring, grooving, pocket machining, milling, boring and linear chamfering Realistic 3D simulated test cuts Direct from machining order tables (no G-/M-codes) Slope machining, 5-face machining
	Interactive MAP (I-MAP)	Part programs can be edited according to guide maps (with figure calculation function)
	Interactive MAP (I-MAP-B)	Solid shape machining function added to I-MAP pattern cycle
	Interactive MAP (I-MAP-C)	Functions to determine cutting conditions and automatically determine drilling cycle added to I-MAP
	Smart OSP Operation	Machining process chart preparation and editing functions: By using the process chart to follow the guidance, rapid preparation for machining operations is possible even without knowing G-/M-code. Machining process chart operating functions: Direct operation from the machining order chart (no G-/M-code). Independent operation for each process or from the middle of a process is possible.
Digital Twin	Virtual Machining	Confirmation tasks are more efficient in a virtual space. Machining trajectories, material scraping, interference checks.*1 High-speed, high-precision machining time estimation. Power consumption (carbon dioxide emissions) estimation.
	Quick modeling	Easy preparation of 3D models of tools, jigs and workpieces. Supply of affluent 3D model data. Selecting 3D models of tools allows not only virtual spaces for digital twins but also automated configuration of real space control data.
	OPC UA for Machine Tools	Communication specification for machine tools compatible with OPC UA communication Compatible with OPC UA version 1.00 (essential functions)
	OSP API KIT	API for Windows®-based application development
Programming Machining Operations	Imperial/metric switch	Program commands and data setting operations are switchable between metric and imperial.
	Operation buffer	10 MB
	Sub-program large capacity operation	When a sub-program is called and executed, the relevant sub-program is searched for and executed
	Program notes	To show notes in part program screens
	Auto scheduled program update	Updates part programs during a scheduled run
	Block skip	Use soft ON/OFF keys on screen to skip execution of a part program Block skip 9 sets
	Program branch	The branch of the part program can be turned ON/OFF with soft keys on the screen (number of sets: 9)
	Work coordinate system	Number of selected sets: 100, 200, 400
	Helical cutting	Circular interpolation + helical axis interpolation
	3D circular interpolation	Three dimensional interpolation
	Skip	Axis travel by G-code, movement skip by sensor input
	Arbitrary angle chamfering	Easy chamfering at an arbitrary corner angle (C, R)
	Synchronized Tapping II	Synchronized tapping, deep bore synchronized tapping, high-speed deep bore synchronized tapping cycle
	Cylindrical side machining	Can easily carry out machining of cylindrical side
	Tool max rotational speed setting	The rotation speed limit is set for each milling tool
	F1-digit feed	Feed speed command by designating the number - external switch type/parameter type
	Programmable travel limits	Per G22, G23
	Axis name designation	Can change axis name by G-code
	Slope machining	Type I/Type II
	Fixture offset	The workpiece coordinate of the rotary/tilting axis is offset
	Dynamic fixture offset	The workpiece coordinate is automatically offset according to the movement of the rotary axis
	Harmonic Spindle Speed Control (HSSC)	The spindle speed is periodically changed to avoid chatter during cutting
	Tool grooving	Hale machining (simultaneous XY + spindle)
	Inverse time feed	Feed rate command with cutting time
	Spindle path control	Contouring per simultaneous control of spindle C and X-Y-Z axes
	Dynamic Tool Load Control	Control of chipping due to tool runout during the machining of difficult-to-cut materials
	Punch tap cycle	High-speed threading cycle using tools dedicated to punch tap
Coordinate change and drawing conversion	Enlarges and reduces drawings, programmable mirror image	
User Task	Common variables: 1,000 or 2,000 sets G-code macros: 100 sets (80 sets added) Input/output variables (16 points each)	
Sequence stop	Stops machining at prescribed sequence number	
Sequence return	Mid-block sequence return	
Pulse handle angle and arc feed	Angle and arc feed with simultaneous 2-axis control by pulse handle	
Tool management	Tool life management	The cumulative number of machined workpieces or cumulative cutting time is calculated, and when the preset value is reached, a spare tool is automatically assigned. Life data of each tool are displayed as graphs; tool life prior notice, tool life warning, tool life special prior notice/warning
	Tool wear compensation	Compensation for the wear amount of the tool
	Tool wear compensation input restriction	Limitation on the amount of tool wear compensation
	3D tool compensation	Designates offset direction at I, J, K
	TOOL-ID (with chips)	Central management of tool data for tools with ID chips
	TOOL-ID (without chips)	Integration of tool data with tools for management and storage
	TOOL-IC	Tool management with Factory Manager manufactured by BIG DAISHOWA SEIKI

External input output	DNC connection	DNC-C/Ethernet DNC-T3	Connected to host using Ethernet I/F for MacMan-net
	Communication functions	DNC-B	Ethernet RS-232C for OSP, connects to host RS-232C; remote buffer operations
Networking		DNC-DT	Remote operation using Ethernet: part programs are downloaded from PCs for the machining operation
		RS-232C interface	RS-232C interface 1CH to 4CH
	FL-net		Connected to host and other machines using FL-net
	Ethernet/IP		Connected to host and other machines using Ethernet/IP
	OSP-MTConnect		MTConnect I/F for production management systems produced by other companies
Measuring	Auto tool length offset/ Auto tool breakage detection		Automatically performs tool length compensation and tool breakage detection Continuous tool gauging: Multiple tools are continuously gauged automatically
	In-magazine tool breakage detection		Automatically performs tool breakage detection in the magazine
	Auto gauging		Checks workpiece dimension, and auto zero offset; Measured data output to file
	Manual measurement		Easy manual tool length compensation, workpiece gauging and zero setting according to guidance on the display
	Interactive gauging		Easy semi-automatic tool length compensation, workpiece gauging and zero setting according to guidance on the display
	NC Gage		Workpiece dimensions and geometrical tolerance can be measured
Monitoring, Adaptive control	One-Touch Spreadsheet		Excel® files assist machining setups
	Collision Avoidance System (Units and actions to prevent interference are limited)		Interference during automatic, MDI and manual operations is prevented Easy modeling of shape data Simultaneous movement with Hyper-Surface II and Tool Center Point Control II
	Real 3-D Simulation		Real time simulation of all machining modes (auto, MDI, manual operation) Solid/cross section/transmission display of workpieces, tool path display, tool shape display With cycle time calculator
	Simple load monitor		Monitors spindle overload (machining stops when overloaded)
	NC operation monitor		NC hour meters for NC start, spindle rotation, cutting, etc. and 4 NC workpiece counters
	Status indicator		NC running lamp, alarm lamp, machining end lamp
	Tool breakage no-load detection		In drilling, detects the no-load cutting status of the spindle caused by tool breakage, triggers an alarm and stops operation
	Synchronized tapping torque monitoring MOP-TOOL		During synchronized tapping, monitors for spindle overload (overload causes machining stop and evacuation) Overload monitoring and adaptive control
	AI Machine Diagnosis*2		AI-based spindle and feed axis diagnostics
	Machine Status Logger		Commands, operations and spindle and feed axis loads are recorded to increase, analyze and improve machining traceability
	Cutting Status Monitor		To reduce machining failure, spindle and feed axis loads are monitored to trigger an alarm, pause operations, and/or trigger evacuation operations
	Machining Navi M-i		Based on chatter vibration during machining, the spindle speed is automatically optimized to stabilize machining
	Machining Navi M-gII+		Chatter vibration during machining is visualized to help automatically select the optimal spindle speed for stable machining
	Feed axis retraction		Pull back in axial direction during power failures
	Tool retract cycle		Execute shelter cycle according to interruption signal
	Workpiece counters on machine		Counted with M02 and M30 or dedicated M-code
	Hour meters on machine		The power ON time, spindle rotation time, NC running time and cutting time are counted
	Operation end buzzer		A buzzer goes off at M02/M30 and M00/M01 and also when an alarm is generated
	Tapping retraction		Retract the tapping tool when a power failure occurs during tapping
	Adaptive control (AC) using external signals		Interruption program function, slide hold, feed axis override activated using external signals
	Tool monitoring system		CARON TMAC8 I/F
	General purpose overload detection		Detect overload in external devices and display an alarm
Automation/Unattended operation functions	Warm-up		Automatically turn on the power to perform warm-up at the preset time
	External program		Push button, rotary switch, digital switch, BCD
	Connection with automated devices		Robot loader I/F, stacker crane I/F, FMS link I/F
High-Speed/High-Accuracy functions	AbsoScale detection		X-Y-Z axes
	Dynamic displacement compensation		Dynamic displacement during acceleration/deceleration is compensated for, to improve machining accuracy
	0.1 μm control		0.1 μm command increments
	Hyper-Surface II		3 linear axes, 3 linear axes + 2 rotary axes
	Inductosyn detection, DD encoder detection		A-axis, B-axis, C-axis
	Straightness compensation		Compensation for linear axis motion
	Misalignment compensation		Compensation for misalignment of the rotary axis rotation center
Energy-saving functions	ECO suite plus		ECO Power Monitor (on-machine wattmeter), ECO Hydraulics, Spindle Power Peak Limiter, External output interface of consumed electricity
Other functions	Circuit breaker		Power shutoff with the detection of earth leakage
	External M-signals		[4 sets, 8 sets] Signals for controlling external devices such as rotary indexing tables
	OSP-VPSII-EX		Allowlist-based virus protection system
	Monitor display language (multi-language)		Language switchable

*1. If the Collision Avoidance System specs are enabled, then interference checks can be performed for structural components of the machine in addition to workpiece, tools, and fixtures.
*2. With AbsoScale detection specs, ball-screw wear detection is possible.
Note: Cannot be selected for some machine specifications.

Table size

Unit: mm

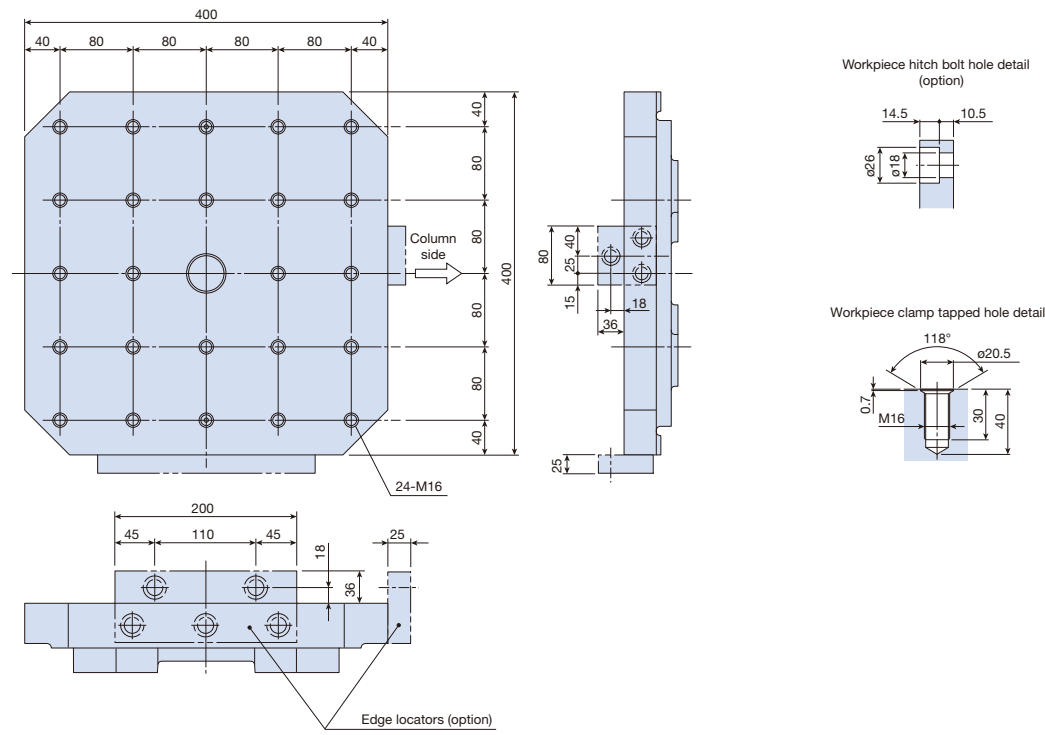

Working range

Unit: mm

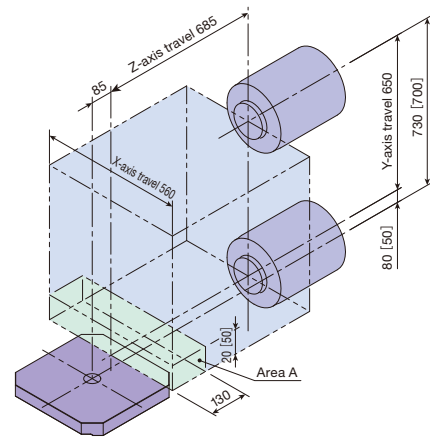

[]: T-slot pallets
 Note: The machine should be operated with caution and with reference to the following interference areas described below.
 Area A: Spindlehead interference
 130 mm when the B-axis is 0, 90, 270, or 360 degrees.
 130 mm or larger when the B-axis is other than 0, 90, 270, or 360 degrees.
 130 mm or larger if edge locators are installed.

Maximum workpiece dimensions

Unit: mm

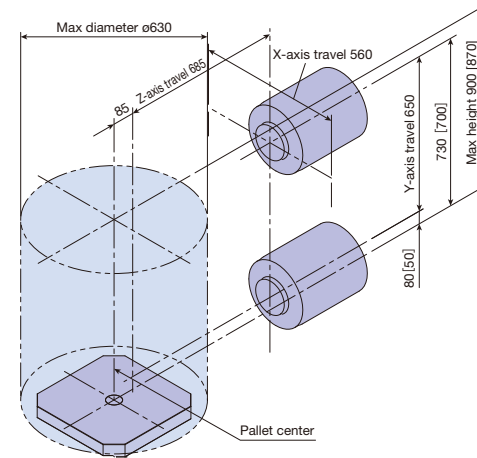

[]: T-slot pallets
 Note: The Z and Y-axis minus limit area is a spindle / pallet interference zone.

Dimensional and Installation Drawings

Unit: mm

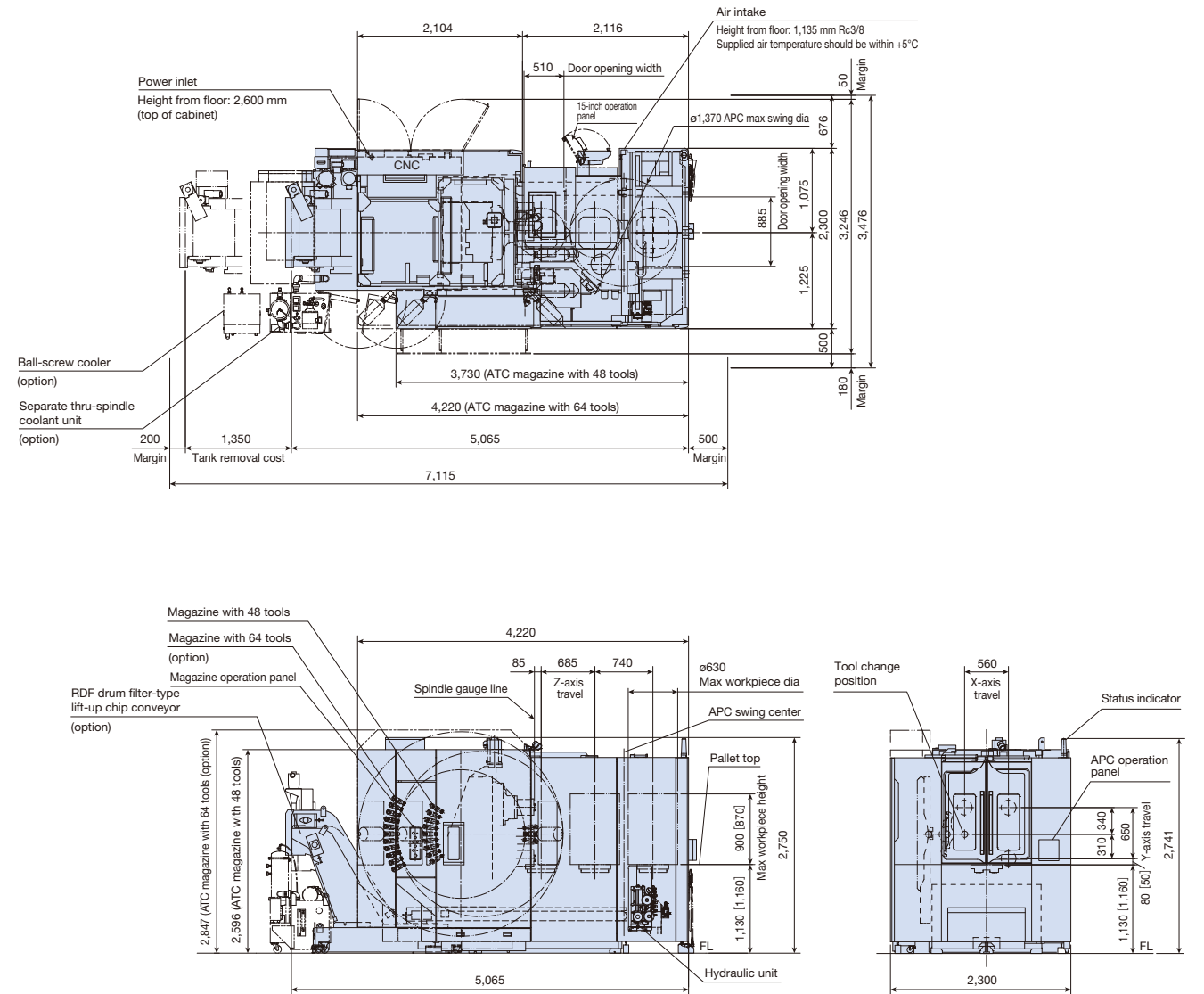

[]: T-slot pallets



When using Okuma products, always read the safety precautions mentioned in the instruction manual and attached to the product.

● The specifications, illustrations, and descriptions in this brochure vary in different markets and are subject to change without notice.
Pub.No.MA-4000H-E-(3a)-200(Jul2025)D

This product is subject to the Japanese government Foreign Exchange and Foreign Trade Control Act with regard to security controlled items; whereby Okuma Corporation should be notified prior to its shipment to another country.



OKUMA Corporation

Oguchi-cho, Niwa-gun,
Aichi 480-0193, Japan
TEL: +81-587-95-7825 FAX: +81-587-95-6074