

# ***MA-8000H***

Horizontal Machining Center



# MA-8000H

Horizontal Machining Center



**For greater productivity of large parts  
with outstanding machining capacity  
and incredible reliability**

## Increased machining capacity with a powerful 10,000 min<sup>-1</sup> spindle (option)

- 10,000 min<sup>-1</sup> No. 50 spindle machining capacity: 1,157 cm<sup>3</sup>/min (S45C)  
1,389 cm<sup>3</sup>/min (FCD450)

## Higher floor space productivity\* with larger work envelope

- X-axis travel: 1,400 mm
- Y-axis travel: 1,200 mm
- Z-axis travel: 1,350 mm

\* Area productivity: Ratio of required machine floor area to processing area

## Outstanding dimensional stability even for long-run machining of large workpieces

- The Thermo-Friendly Concept minimizes dimensional changes due to ambient temperature changes and machining heat.  
Achieves outstanding dimensional stability even during long-run machining.

## Contributing to the realization of a decarbonized society by achieving high productivity and high precision, together with environmental friendliness

- Thermo-Friendly Concept and ECO suite plus, an energy-system that meets the needs of a decarbonized society, autonomously achieve both stability of dimensional accuracy and energy consumption reduction.

## An operator-friendly machine design

- Daily inspection equipment is placed at the rear of the machine on the operator's side to shorten the work path and improve operability.

## Chip discharge that maximizes uptime

- Effective workspace area washing suppresses chip accumulation and reduces frequent chip cleaning inside the machine.

## "Sludgeless Tank" enhances stable operations (option)

- The Sludgeless Tank removes coolant impurities (sludge) that affect machining effectiveness—drastically reducing the man-hours for troublesome tank cleaning.

## Automation support to further improve productivity

- Flexible support for automation; multi-pallet APC systems effective hydraulic/pneumatic fixture port arrangements

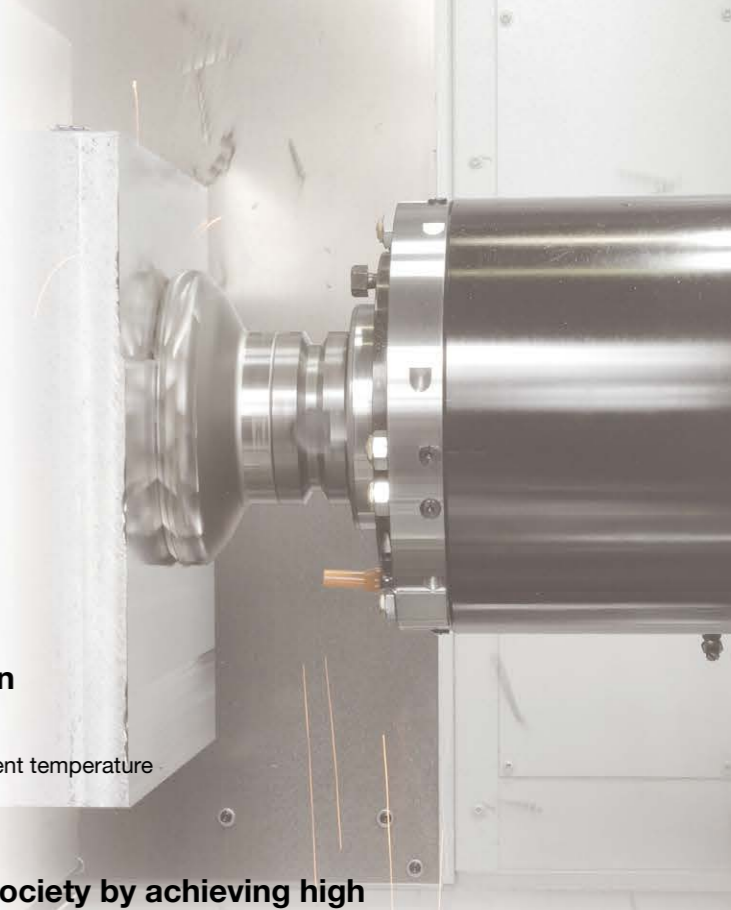
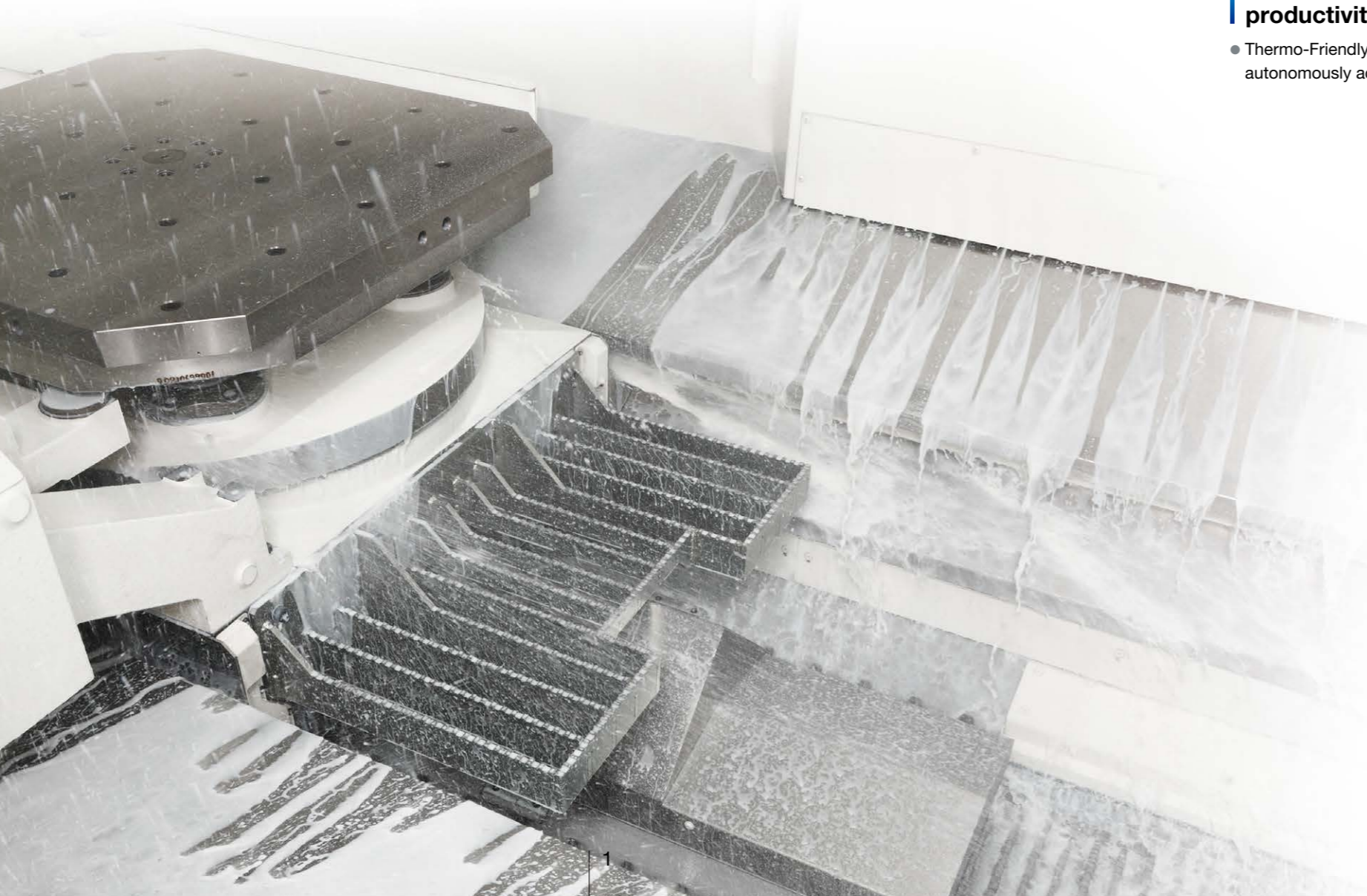
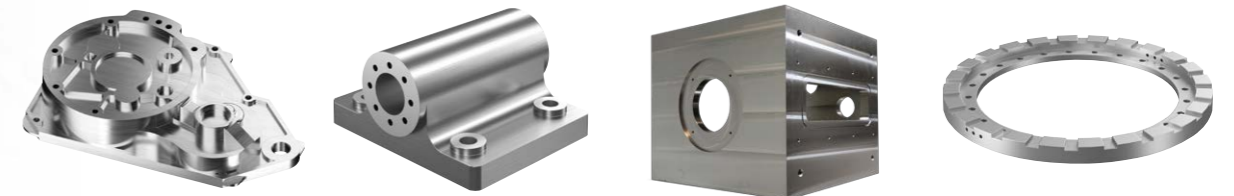

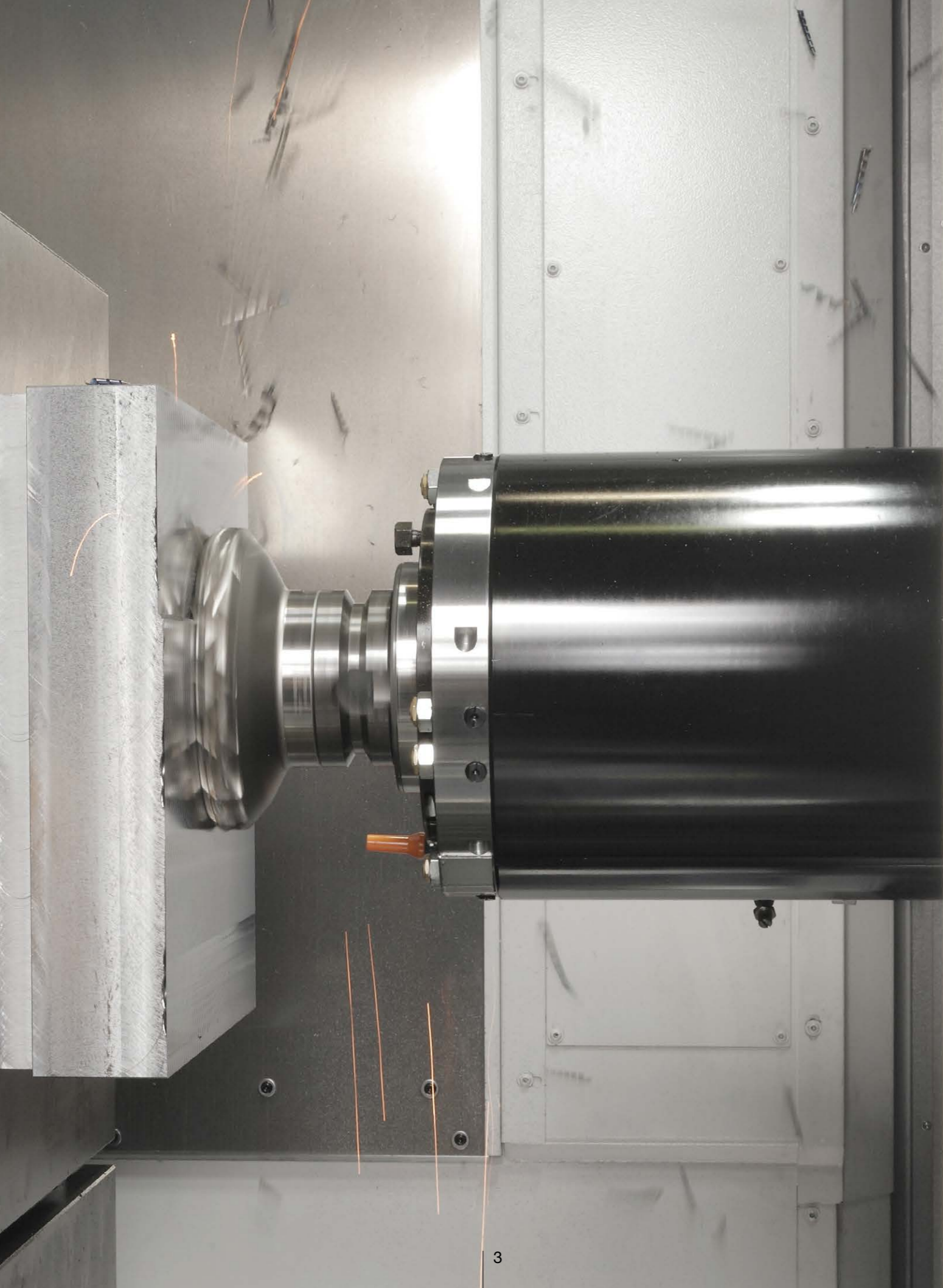

# Increased machining capacity with a powerful 10,000 min<sup>-1</sup> spindle (option)

## Lineup with powerful spindle: 10,000 min<sup>-1</sup> (option)

Delivering high machining capacity across a wide range of low to high speeds. Effectively handles a wide range of workpieces from heavy-duty cutting of steel to aluminum machining.

### Handling a wide range of applications from heavy-duty to high-feed machining

#### Powerful spindle 10,000 min<sup>-1</sup> No. 50 (option)

- Max output: **45/30 kW** (20 min, 60% ED/cont)
- Max torque: **652/349 N-m** (15% ED/cont)
- Machining capacity:

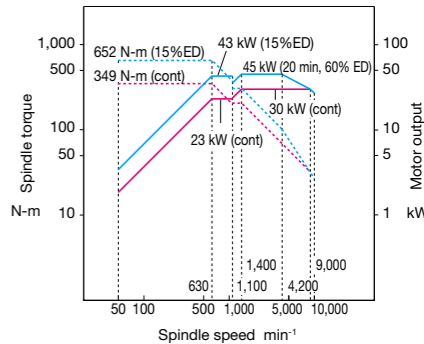

#### Material: S45C Actual data

##### Milling capacity

**1,157 cm<sup>3</sup>/min**

Tool: ø160 mm face mill  
16 blades (carbide)  
Spindle speed: 597 min<sup>-1</sup>  
Cutting Speed: 300 m/min  
Feed rates: 3,826 mm/min  
Cut width × depth: 112 mm × 2.7 mm  
(Cut position: 741 mm from pallet top)

##### End milling capacity

**632 cm<sup>3</sup>/min**

Tool: ø50 mm end mill  
4 blades (carbide)  
Spindle speed: 1,318 min<sup>-1</sup>  
Cutting Speed: 207 m/min  
Feed rates: 1,581 mm/min  
Cut width × depth: 10 mm × 40 mm  
(Cut position: 776 mm from pallet top)

#### Material: FCD450 Actual data

##### Milling capacity

**1,389 cm<sup>3</sup>/min**

Tool: ø160 mm face mill  
16 blades (carbide)  
Spindle speed: 497 min<sup>-1</sup>  
Cutting Speed: 250 m/min  
Feed rates: 3,180 mm/min  
Cut width × depth: 112 mm × 3.9 mm  
(Cut position: 742 mm from pallet top)

##### End milling capacity

**1,000 cm<sup>3</sup>/min**

Tool: ø80 mm end mill  
4 blades (carbide)  
Spindle speed: 980 min<sup>-1</sup>  
Cutting Speed: 246 m/min  
Feed rates: 980 mm/min  
Cut width × depth: 17 mm × 60 mm  
(Cut position: 794 mm from pallet top)

Note: The "actual data" referred to above for this brochure represent examples, and may not be obtained due to differences in specifications, tooling, cutting condition, and others.

## Spindle variations

### Mainly for steel workpieces

#### Standard spindle No. 50

- Spindle speed: 6,000 min<sup>-1</sup>
- Max output: 30/22 kW (10 min/cont)
- Max torque: 606/349 N-m (10 min/cont)

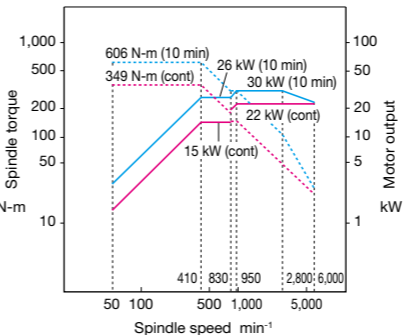

### Machines materials from aluminum to steel

#### Wide-range spindle No. 50 (option)

**Max output: 45 kW**  
(1.2 times more than previous model)

- Spindle speed: 12,000 min<sup>-1</sup>
- Max output: 45/30 kW (10 min, 25% ED/cont)
- Max torque: 419/194 N-m (2 min/cont)

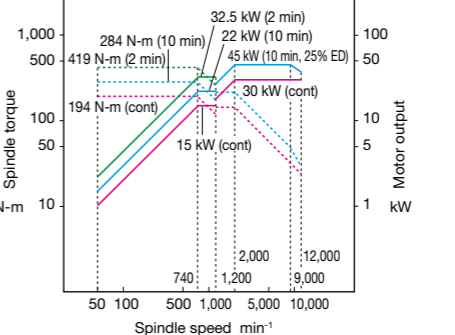

### Machines inconel, titanium and other difficult-to-cut materials

#### High-torque spindle No. 50 (option)

**Max torque: 1,071 N-m**

- Spindle speed: 6,000 min<sup>-1</sup>
- Max output: 45/37 kW (20 min/cont)
- Max torque: 1,071/637 N-m (3 min/cont)

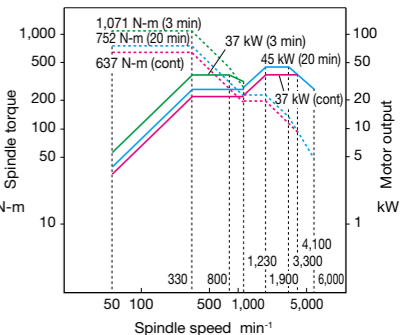

# Higher floor space productivity with larger work envelope

## Optimal travels for the large parts applications

With longer X-, Y-, and Z-axis travels, a wider range of applications can be handled.

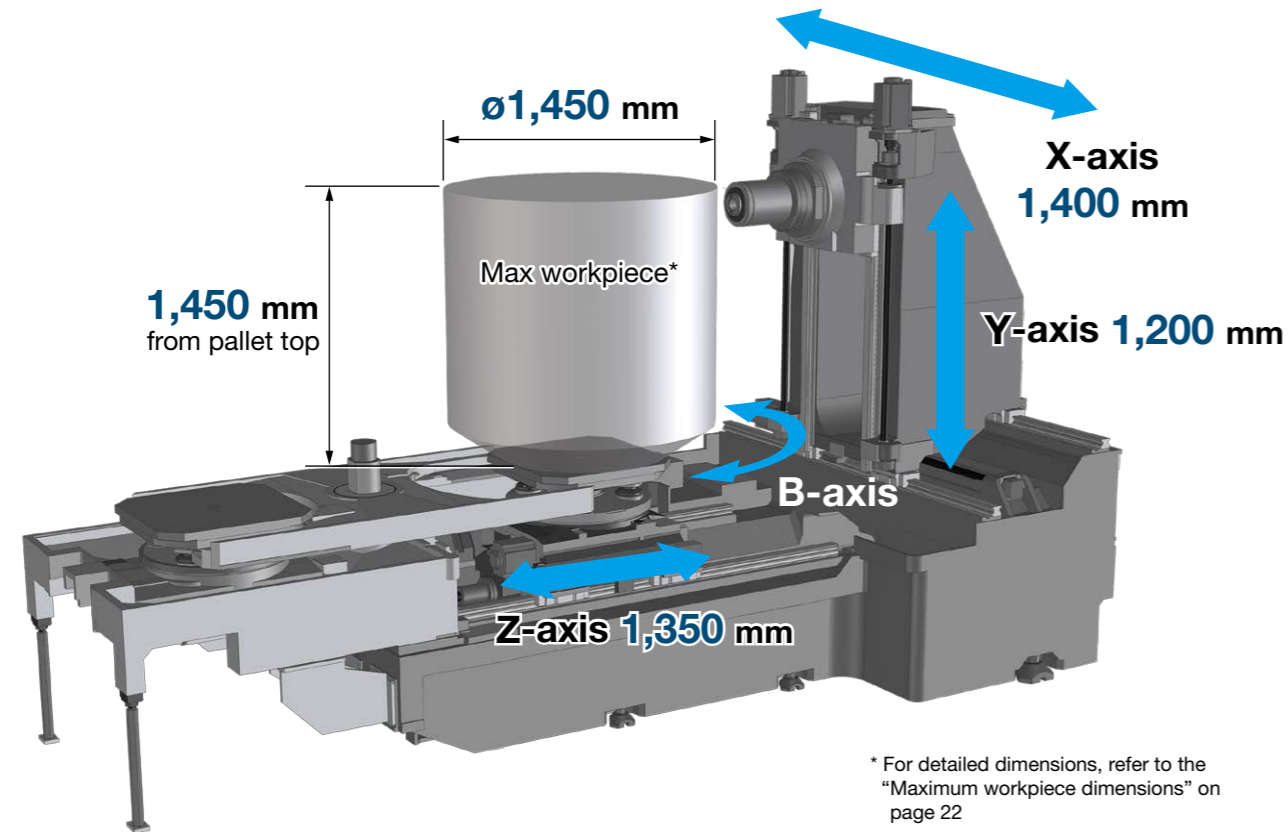

### Larger work envelope

- X-axis travel: **1,400 mm**
- Y-axis travel: **1,200 mm**
- Z-axis travel: **1,350 mm**

### Load capacity

**3,000 kg** (only for option / two-sided rotary APC)

### Max workpiece size

**ø1,450 x 1,450 mm**

### Max tool length

**800 mm** (option)

### High speed operations

- Rapid traverse: 50 m/min (X-, Y-, Z-axis)
- Tool change: 2.0 sec (T-T)<sup>\*1</sup>  
4.7 sec (CTC min)<sup>\*2</sup>
- Pallet change time: 17.5 sec<sup>\*1</sup>  
18.3 sec<sup>\*2</sup>
- Table indexing time: 1.9 sec<sup>\*3</sup>/90° (1 degree indexing)

<sup>\*1</sup>. MAS standard measurements (formerly JIS B 6013)

<sup>\*2</sup>. ISO 10791-9 (2001) (JIS B 6336-9) measurements

<sup>\*3</sup>. At low inertia

# Outstanding dimensional stability even for long-run machining of large workpieces



## Thermo-Friendly Concept

The unique approach of "accepting temperature changes."

### Eliminate waste with the Thermo-Friendly Concept

Okuma's Thermo-Friendly Concept achieves high dimensional stability not only when the room temperature changes, but also at machine startups or when machining is resumed.

The warm-up operation time to stabilize thermal deformation is shortened, and the burden of dimensional correction when resuming machining is reduced.

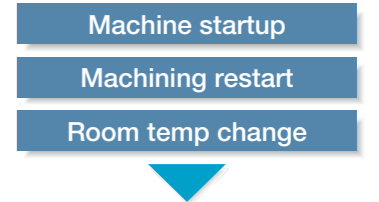

**High dimensional stability**

### TAS-C (Thermo Active Stabilizer – Construction)

TAS-C estimates and accurately controls the volumetric thermal deformation of the machine's construction due to ambient temperature changes; based on data from properly placed sensors, feed axis positions, and actual machine thermal deformation characteristics.

### TAS-S (Thermo Active Stabilizer – Spindle)

The TAS-S spindle thermal deformation control takes into account various conditional changes such as the spindle's temperature data, modification of the spindle rotation and speed, as well as spindle stoppage. The spindle's thermal deformation will be accurately controlled, even when the rotating speed changes frequently.

## Machine is structurally designed to achieve outstanding accuracy

### Highly rigid bed

Easy installation thanks to bed that does not twist. Supporting stable, high accuracy over a long period.

### Ball-screw bracket

The ball-screw brackets at both ends of the X-Y-Z axes are reinforced and combined for highly accurate drive and positioning.

### Ball-screw cooling

X-Y-Z axes ball-screw cooling and motor bracket cooling are standard. Assuring stable accuracy during high rates of operation.

### Indexing table and pallet

Highly accurate indexing table

- Standard: Curvic coupling (1 degree indexing)
- Optional: NC (0.001 degree indexing)

The pallet seating on a tapered cone achieves highly accurate positioning and excellent durability.

### The exactness of bi-directional positioning

(AbsoScale actual data)

- X-axis (travel: 1,400 mm) **3.0 μm**
- Y-axis (travel: 1,200 mm) **3.4 μm**
- Z-axis (travel: 1,350 mm) **2.3 μm**

### Bi-directional repeatability

(AbsoScale actual data)

- X-axis (travel: 1,400 mm) **2.4 μm**
- Y-axis (travel: 1,200 mm) **2.8 μm**
- Z-axis (travel: 1,350 mm) **1.6 μm**

Note: The "actual data" referred to above represent examples of data obtained by using ISO 230-2 test methods done at Okuma factories, and they are not guaranteed values.

# Contributing to the realization of a decarbonized society by achieving high productivity and high precision, together with environmental friendliness

## Highly productive, accurate and eco-friendly **Green-Smart Machine**

Okuma has worked to reduce energy consumption in order to achieve carbon neutrality at the three factories in Japan which are our main production bases.

We have realized high productivity through automation and process-intensive machining, in addition to high-accuracy machining, and we then introduced the use of green energy to transform the three domestic factories into carbon-neutral factories.

“Green-Smart Machines” is our definition of Okuma’s intelligent machine tools, which autonomously achieve stable dimensional accuracy and reduced energy consumption, to support environmentally friendly production. Our policy is to deploy “Green-Smart Machines” fully, to help achieve a carbon-free society.

Starting with products manufactured at those carbon-neutral factories and distributing them globally, we will partner with our customers to address the social challenges faced by the manufacturing industry.

**Green-Smart Machines** are **environmentally friendly** products that autonomously achieve stable dimensional accuracies and reduced energy consumption.

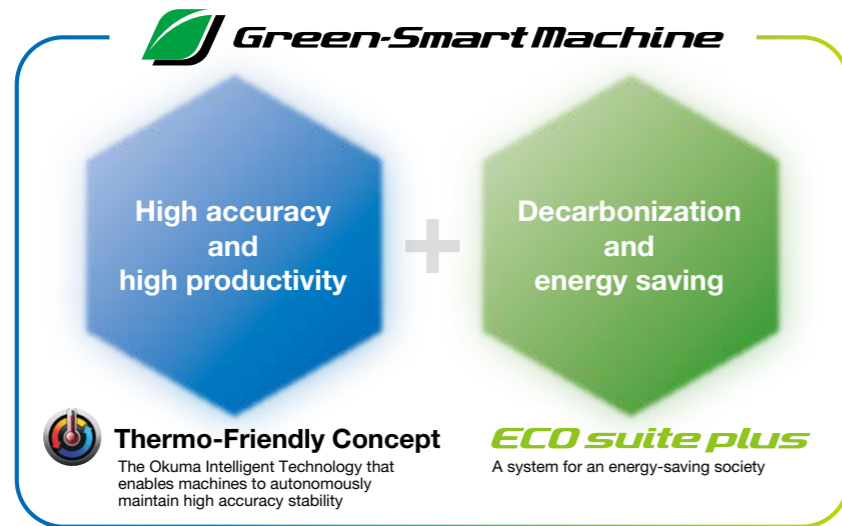

### Thermo-Friendly Concept

The Okuma Intelligent Technology that enables machines to autonomously maintain high accuracy stability

The unique concept of accepting temperature changes achieves consistent high accuracy without special coolers or excessive air conditioning.

#### Reduction of warm-ups and dimensional compensation

Reduce the time needed for daily warm-ups and dimensional compensation to adjust to ambient temperature changes.

#### Reduction of power used for air conditioning

Maintain high stability of dimensional accuracy even if the air conditioning temperature range is expanded.

#### Reduction of machine body coolers

Achieve outstanding dimensional accuracy without any special machine body cooling being required to maintain accuracy.

### The Okuma way to cool

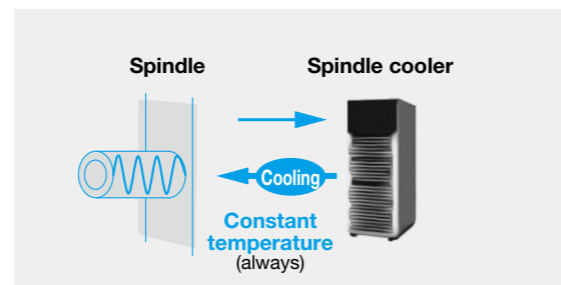

By always setting a constant coolant supply temperature, the cooler power consumption is reduced.

## ECO suite plus A system for an energy-saving society

### ECO Idling Stop

Auxiliary equipment consume a substantial portion of the power used in a factory. This function enables each of them to be turned off when not needed to reduce power consumption.

In addition to when automatic operation is suspended, it is now possible to stop idling during manual operation. Power consumption and carbon dioxide emissions are reduced without conscious effort by the operator.

### ECO Operation

By using only the required peripherals (chip conveyor, mist collector), energy-saving operations are possible.

### ECO Power Monitor

Power is shown individually for spindle, feed axes, and auxiliaries on the OSP operation screen.

In addition to regenerative power, the energy-saving benefits from auxiliary equipment stopped with ECO Idling Stop can be confirmed on the spot.

### 1 Check carbon dioxide emissions on the spot

With ECO suite plus, you can also check the power consumption of each device.

### 2 Simultaneously records operating status and carbon dioxide emissions

With ECO suite plus, recording carbon dioxide emissions for each device, and data output is possible.

### 3 Analyze carbon dioxide emissions and improve machine tool operation

With ECO suite plus, not only the display on the machine but data analysis for each device is also possible on a PC, to see a more detailed carbon dioxide emission analysis.

The machine monitors the cooling level when not machining, and proactively turns off the cooler while maintaining high accuracy conditions.

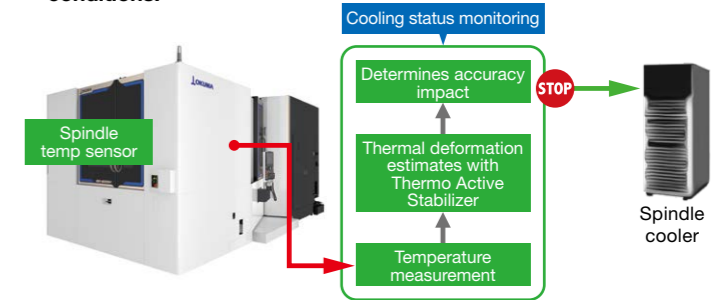

ECO PARAMETER	ECO IDLE STOP (1/4)	ECO OPERATION
ECO IDLE STOP ELAPSED TIME	000:00:00	REMAINING TIME UNTIL ECO IDLE STOP READY 12:48
Chip conveyor interval control	OFF	PARAMETER UNIT
Chip conveyor interval/active time	100	[min]
Chip conveyor interval/suspended time	200	[min]

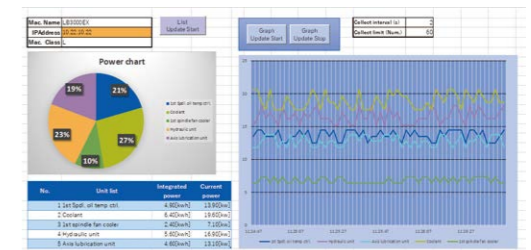
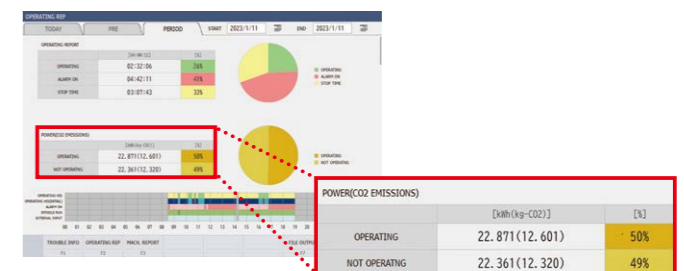
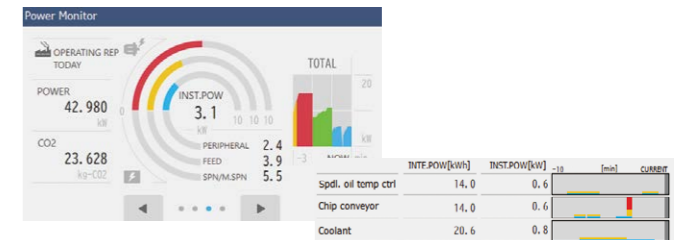

Example of utilizing One-Touch Spreadsheet (option) to create visual feedback of machine’s power consumption and carbon dioxide emissions.

# An operator-friendly machine design

## Good machine access and better work efficiency

### Improved setup station operator efficiency

#### Wider APC door opening width

- More efficient setups for maximum-size parts

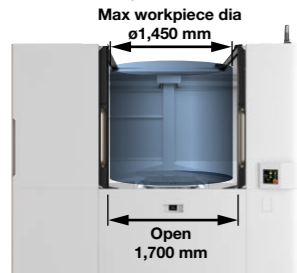

#### Ceiling is open when the door is open

- Easy part load/unload by crane
- Lighting is good, and coolant doesn't drop in the workspace area



Setup station

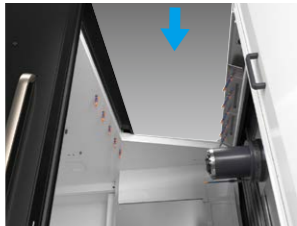

Workspace area

### Maintenance improved by grouping daily inspection equipment at the rear of the machine

- Hydraulic unit is located on the operation side and daily check points are located at the rear of the machine.
- Operator efficiency also improved with shortest workflow

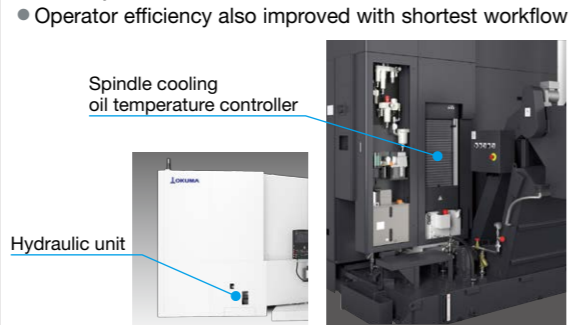

### Good accessibility to the spindle and workpiece

- 520 mm from tool load/unload button to spindle



### Space around the machine — operator preference steps available

- A larger step (option) can expand the operator's working area.

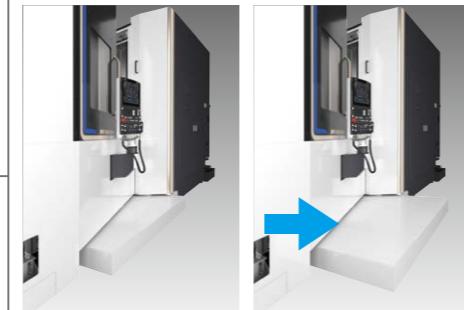

220 mm (standard)

700 mm (option)

### Operation panel mounted on the left Swivel movement improves visibility and workability

- Workpiece and operation screen XYZ directions are the same
- Operator can be close to the screen, for less fatigue



The angle can be adjusted

- Operation panel moves horizontally toward spindle

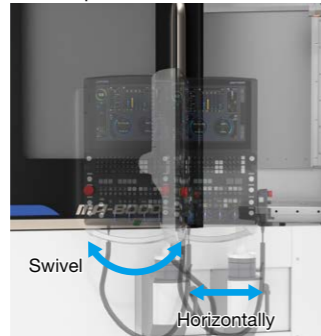

Swivel

Horizontally

### In-machine steps (standard) improve in-machine operator efficiency

- Steps move with table and stationary step at workspace area entrance

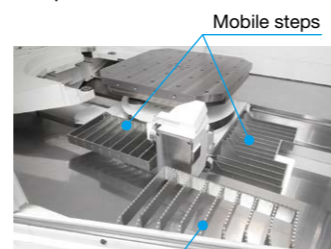

Mobile steps

Stationary step

# Chip discharge that maximizes uptime

## With simple workspace covering and reinforced coolant applications, efficient chip discharge and long-run machining possible

Just Z-axis travel single cover and a smooth X-, Y-axis telescopic covers suppress chip accumulation.

Moreover, in dry machining without coolant, washing only the lower workspace area with coolant is possible.

In-machine washing prevents likely areas of chip accumulation, by cleaning away chips to maintain long-run production runs.

### Chip discharge and workspace area designed to prevent chip accumulation

Stronger workspace lower area with large-volume coolant wash and hinge conveyor smoothly removes accumulated chips out of the machine.

From the upper area of the workspace, a shower coolant system (option) and coolant from the X-, Y-axis telescopic covers suppress chip accumulation.



Preventing chip accumulation with smooth X-, Y-axis telescopic covers and Z-axis stainless steel single cover.

Flat covers in the workspace prevent chip accumulation.

Center trough design enhances large amount of chip discharge out of the machine.



Z-axis stainless steel single cover



X-, Y-axis telescopic covers

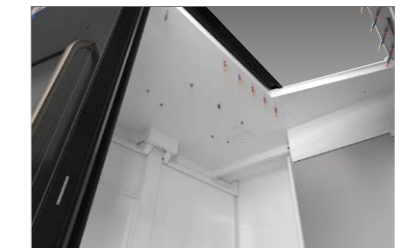

### Out-of-machine chip discharge

Optional a lift-up chip conveyor that discharges chips to the outside of the machine, and a Sludgeless Tank (option) that efficiently removes sludge are available.

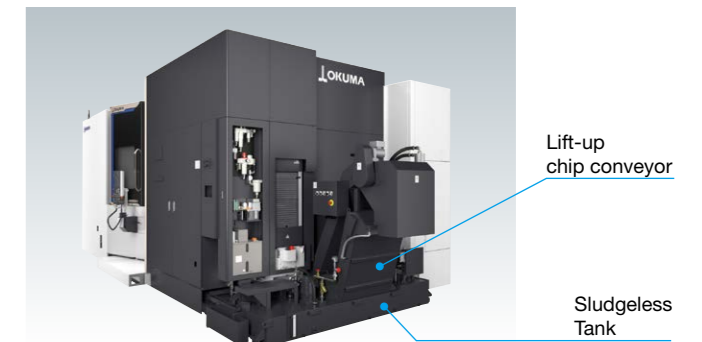

Lift-up chip conveyor

Sludgeless Tank

# “Sludgeless Tank” enhances stable operations (option)

## Sludgeless Tank (option)

Reducing waste liquid by suppressing coolant deterioration

### Coolant maintenance work is significantly reduced

### The environmental impact of coolant disposal is also minimized

The Sludgeless Tank continuously circulates cutting fluid within the tank, efficiently collecting sludge to prevent accumulation and significantly reducing issues and maintenance work. This significantly reduces the frequency of tank cleaning, enabling stable operation over long periods and improving productivity. It also extends the cutting fluid’s lifespan, helps prevent spoilage and odors, and creates a better working environment. Furthermore, reducing the frequency of cutting fluid changes decreases industrial waste and lessens the environmental impact. Coolant supplied with thru-spindle coolant specifications uses a bag filter to collect even finer sludge and improve machined surface quality.

**Sludge removal rate 99%** (when the material is casting and aluminum)  
 Note: · After secondary filtration (cyclone filter) permeation  
 · Okuma evaluated removal rate

**No tank cleaning for 3 years**  
 (okuma equipment actual data)

**No coolant replacement for 3 years**  
 (okuma equipment actual data)

Note: If the Sludgeless Tank is chosen, it is necessary to select a hinge + scraper chip conveyor with a drum filter.

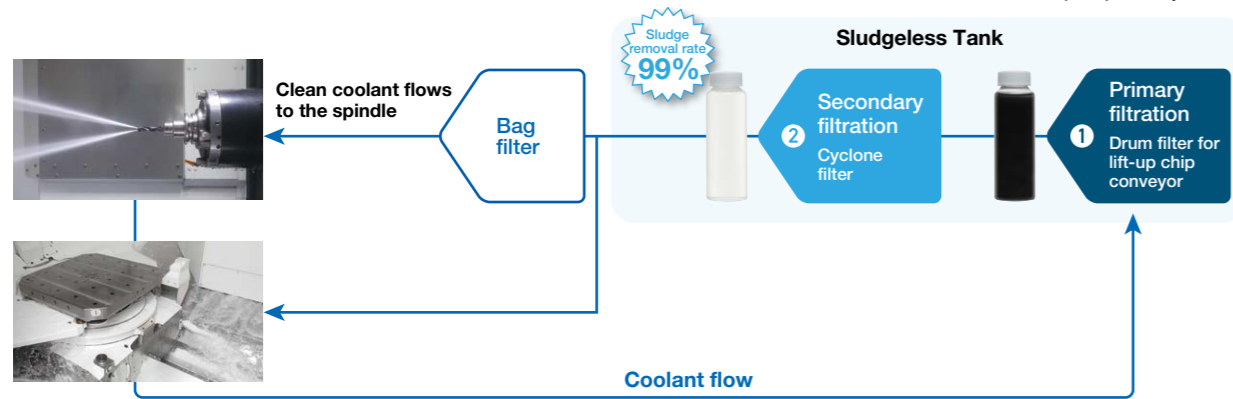
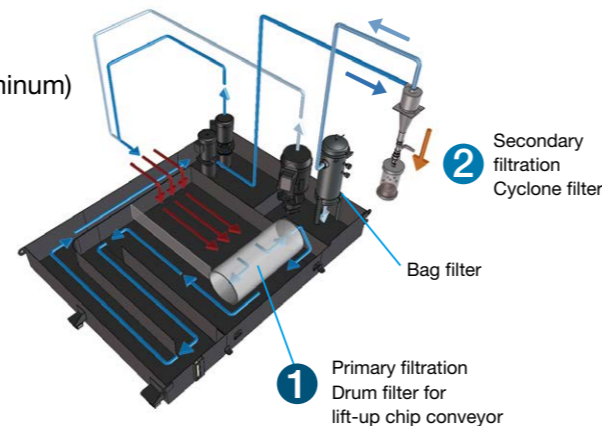

### Keeping spindle tapers clean

The three filtration devices in the Sludgeless Tank and coolant suction inside the spindle reduce dirt on the spindle taper and lessen defective machining.

Note: Suction of coolant from the spindle also limits the outflow of coolant to the spindle taper when changing tools.

### Compact—integrated with the Thru-Spindle Coolant tank



# Automation support to further improve productivity

## Flexible automation support

### Equipped with a large number of thru-pallet fixture ports (option)\*

The setup station pallet base can be equipped with up to 16 fixture ports for hydraulic and pneumatic pressure, and the workspace area table base can have up to 8 ports for flexible automation applications. Simplifying complex hydraulic circuits is possible, making it easier to design auto-clamp fixtures. Customers benefit from more agile system building to handle diverse automation requirements.

#### Setup station

**Max 16 ports (hyd/pneu)\*1, \*2**

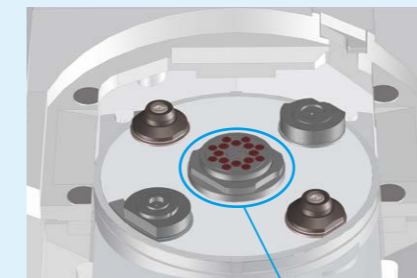

#### For the setup station 16 ports preps

With 16 ports, arrangements for robotic and automation applications will be expanded, and more flexible fixture support will be possible. With 16 ports, a large number of parts can be mounted, and a different workpiece can be clamped on each side of a 4-sided tooling block fixture.

\*1. 8 or 16 ports available.  
 (for 16 ports, max 12 hydraulic ports)  
 \*2. Hydraulic pressure: 7 MPa.

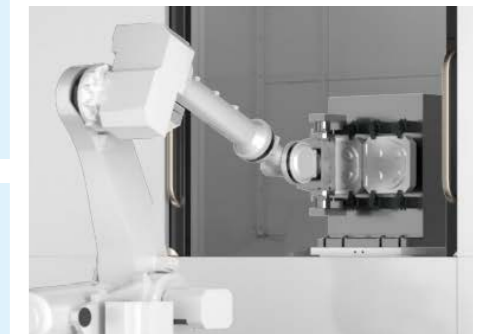

Example of robotic automation

#### Workspace area (table)

**Part load/unload\*1: Max 7 ports\*3**

**Workholding clamps\*2: Max 8 ports\*3**

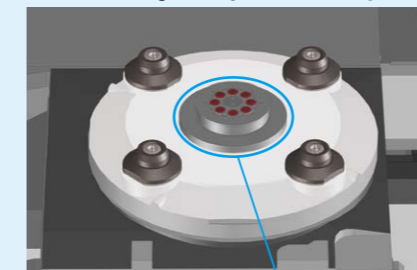

#### Part load/unload in workspace area (table) also possible

“Part load/unload” fixture ports also allow part load/unload in the workspace area in the machine. Adjustment times for trial cuts can be shortened and fixture readjustments in the workspace improve work efficiency. With more ports, hydraulic applications have increased, eliminating complicated hydraulic circuits arrangements.

\*1. For part load/unload in the workspace area, **select part load/unload.**  
 \*2. If the above is not required, **select workholding clamps.**  
 \*3. Hydraulic pressure: 7 MPa.

### Auto Setup Station Pallet Rotate (option)

With the automatic indexing setup station, the pallet rotates 90° each time the foot switch is pressed.

Workability at the setup station has been improved, and robotic loading/unloading from multi-sided fixtures is also supported.\*

\* This function is available only with the two-sided rotary APC.

# Flexible production of large-variety workpiece applications

## An impressive lineup of automation systems

### Flexible APC systems

Multi-pallet APCs allow the operator to single setup a large number of workpieces, and use the extra time available for other jobs. Setups at the end of the day for untended operations are also a benefit.

- Multi-pallet APC connects to standard 2-pallet rotary-shuttle APC
- Pallet change time is the same as in the standard APC
- Can be adapted to match plant layout and type of production

Note: With the multi-sided APC, the 1,000 × 1,000 mm pallet size and the 3,000 kg pallet loading capacity cannot be selected.

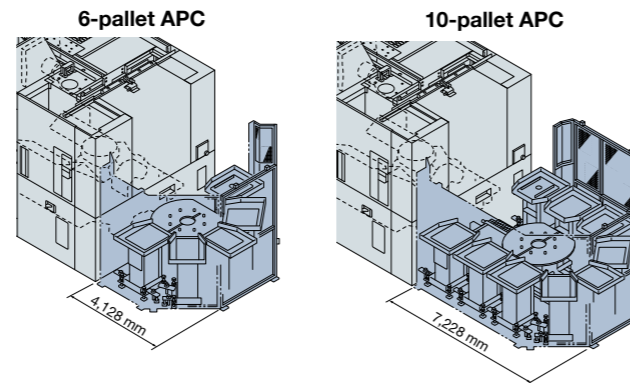

### Auto tool changer

The standard number of tools that can be stored is 60. Flexible, high-volume tool storage systems available for adding more types of workpieces. Matrix magazines store larger numbers in compact, quick tool-change arrangements.

ATC magazine capacity	Magazine type	ATC tool			
		Max diameter		Maximum length, mass, moment	
		w/adjacent	w/o adjacent		
40 tools, 60 tools (standard)	Chain magazine	ø140 mm	ø240 mm	Max length 600 [800] mm	Max mass 25 kg Mass moment 36.75 N-m
81 tools, 111 tools, 141 tools, 171 tools	Matrix magazine (171-tool cabinet)	ø105 mm (standard)	ø240 mm (large size)		
195 tools, 225 tools, 255 tools, 285 tools	Matrix magazine (285-tool cabinet)	ø130 mm (mid-size)			
320 tools, 400 tools	Multiple magazine	ø135 mm	ø240 mm		

[ ]: Option



Matrix system ATC magazine (option)

### Ready for FMS applications

- An FMS with a smart, expandable stacker crane system

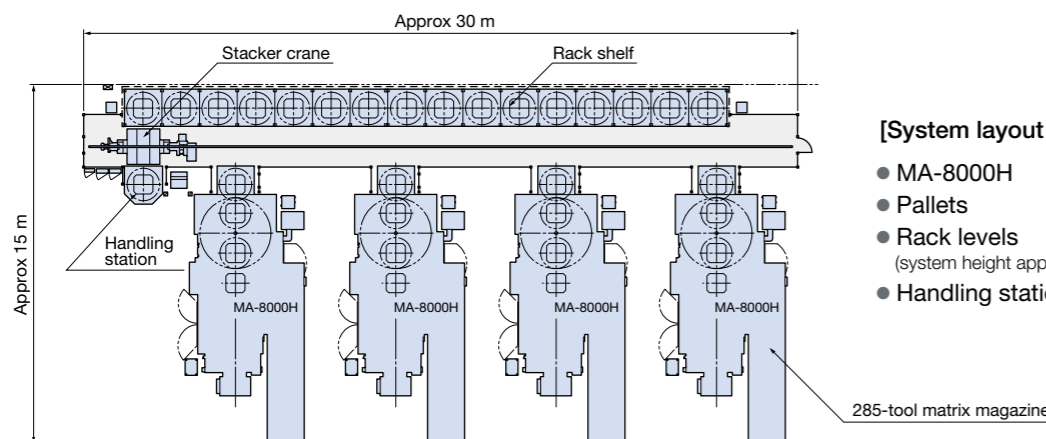

#### [System layout example]

- MA-8000H 4
- Pallets 32
- Rack levels 2 (system height approximately 5.5 m)
- Handling station 1

285-tool matrix magazine

# A next-generation CNC that makes manufacturing DX (digital transformation) a reality

## OSP-P500

### Improved productivity and stable production

As Your Single Source for M-E-I-K (Mechanics - Electronics - IT - Knowledge) merging technology, Okuma offers this CNC to build an advanced “digital twin” that faithfully reproduces machine control and machining operations and creates new value. In addition, Okuma offers productivity improvement and stable production with ease of use that allows customers to use their machining know-how, an energy-saving solutions that achieve both high accuracy/productivity and eco-friendly products, with robust security protection against increasing threats of cyber-attacks.

Faithful reproduction of machines and processing — Digital support for shop floor work  
Digital Twin (option)

“Okuma’s **two digital twins**” made possible by an office PC and a next-generation CNC reduce machine downtime and improve machine utilization

Simulation using the latest machine information can be achieved with an office PC and OSP-P500 installed on the physical machine. This enables preparation for machining in advance in the office environment (front loading). Preparing machining for the next part while continuing machining can reduce the preparation time for the physical machine. When a problem occurs on the shop floor, it can be solved quickly on site without going back to the office.



15-inch operation panel

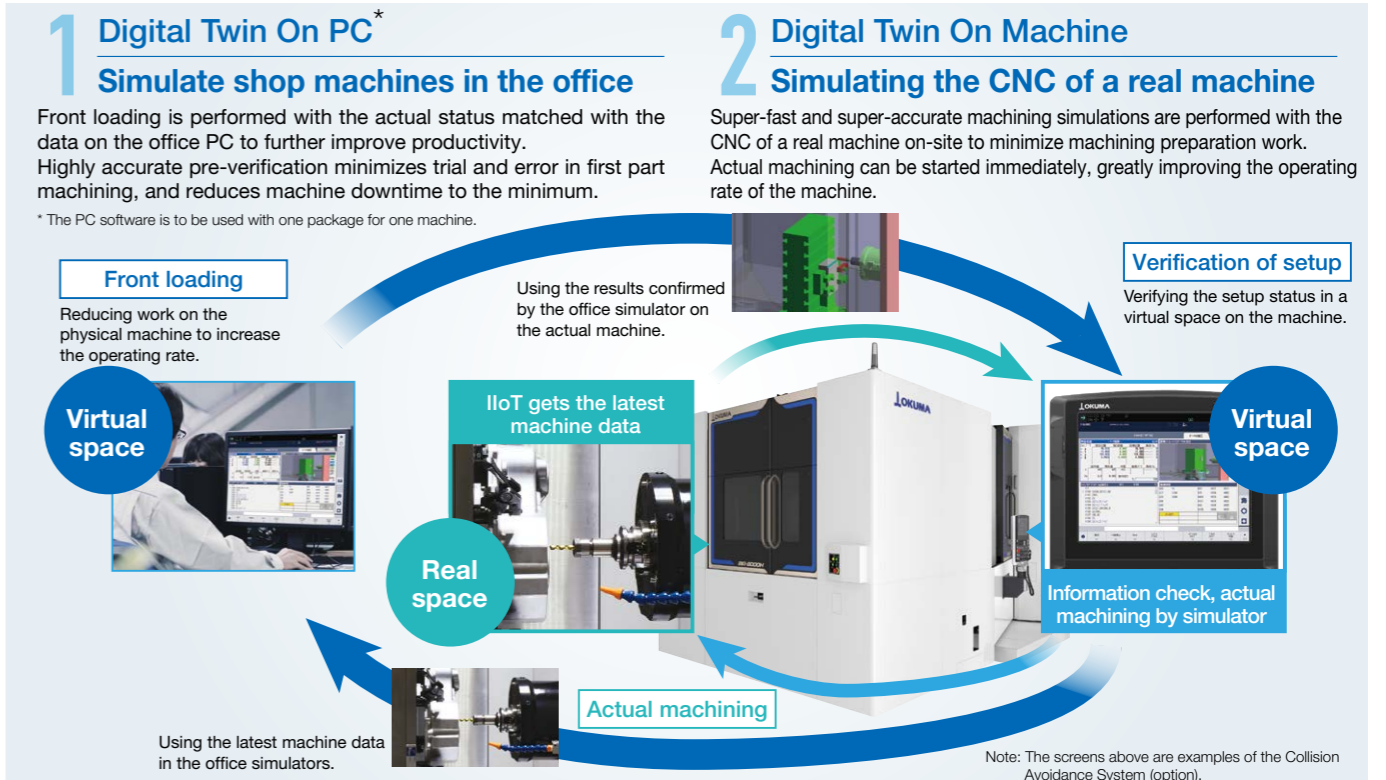

## Connect Plan Get Connected, Get Started, and Get Innovative with Okuma “Monozukuri”

### Connect, Visualize, Improve

Okuma’s Connect Plan is a system that provides analytics for improved utilization by connecting machine tools and visual control of factory operation results and machining records. Simply connect the OSP and a PC and install Connect Plan on the PC to see the machine operation status from the shop floor, from an office, from anywhere. The Connect Plan is an ideal solution for customers trying to raise their machine utilization.

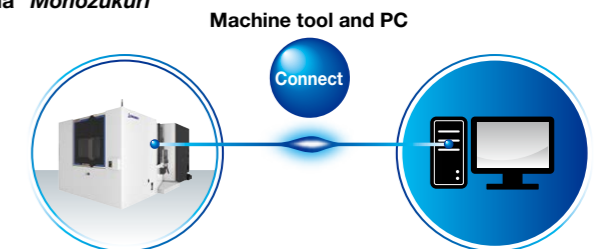

# Advanced technology—effective for machine shops

## AI Machine Diagnosis Function (option)

Machine tool diagnostics technology with artificial intelligence (AI)

### With predictive maintenance, prevent machine stoppages just in time

AI installed in the control system detects abnormalities in the spindle and feed axes before they lead to issues, preventing prolonged machine downtime and enabling stable, long-term production. The operators themselves can easily diagnose the machine by following simple screen guidelines on the Okuma control.

Notes:  
AI diagnostic models are already installed, and diagnoses can be performed by the machine itself. AI diagnostic models can be updated through Okuma's Connect Plan. With AbsoScale detection specs, ball-screw wear detection is possible.

Self-diagnosis of spindle and feed axis status with AI

**AI Spindle Diagnosis Function**

Detects damage to spindle bearings

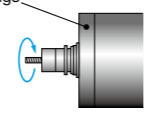

**AI Feed Axis Diagnosis Function**

Detects ball-screw wear condition

Detects damage to ball-screw support bearings

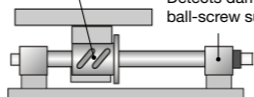

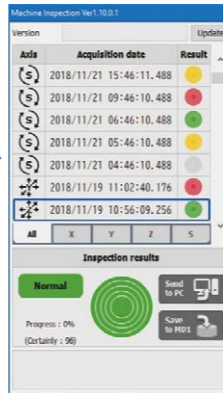

Axis	Acquisition date	Result
S	2018/11/21 15:46:11.488	Normal
S	2018/11/21 09:46:10.488	Normal
S	2018/11/21 06:46:10.488	Normal
S	2018/11/21 05:46:10.488	Normal
S	2018/11/21 04:46:10.488	Normal
S	2018/11/19 11:02:40.176	Normal
S	2018/11/19 10:56:09.256	Normal

## Turn-Cut (option)

Turning operations on machining centers

### Shorter lead times with process-intensive machining

Simultaneously controlling X-Y circular motion with the tool edge position rotated by the spindle tool enables lathe-like turning.

- Tapers also possible
- Hole making with different diameters — with one tool
- IDs and ODs can be machined when they exceed the maximum tool diameter that ATC can handle

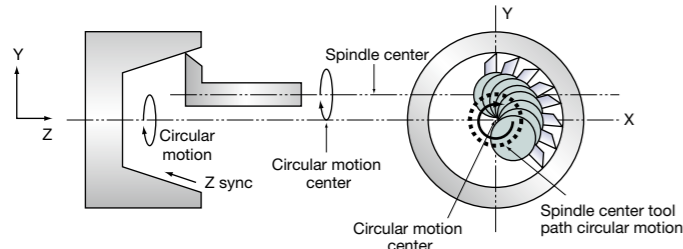

Note: AbsoScale detection and ball-screw cooling required

### Example of use: Turning valve parts

With Turn-Cut, it's possible to turn the seating surfaces required by gas pipe sealing conditions.

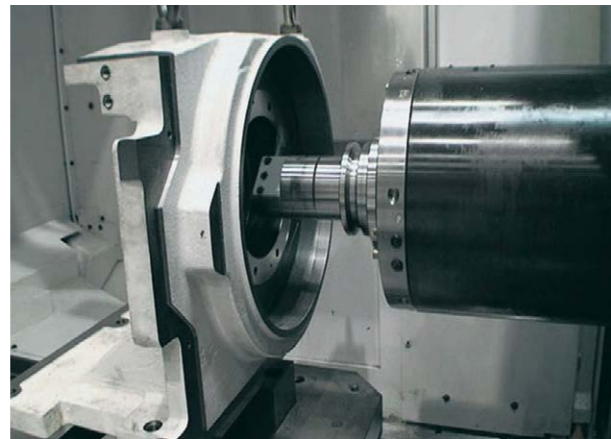

## Flat-Tool Grooving (option)

Airtight seal grooving

### Grooving with high sealability

The spindle phase is precisely synchronized with cutting edge motion, to perform highly accurate grooving.

- Getting high sealability without hand finishing.
- Complex seal groove curves also cut with flat tools.



## Collision Avoidance System (option)

Collision prevention

Allowing operators to focus on making parts

### World's first "Collision-Free Machine"

CAS prevents collisions in automatic or manual mode, providing risk-free protection for the machine and great confidence for the operator.

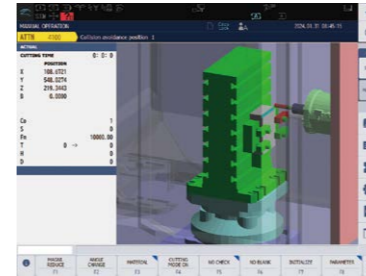

## SERVONAVI

Optimized Servo Control

Achieves long term accuracy and surface quality

### SERVONAVI AP (Automatic Parameter setting)

#### Work Weight Auto Setting

- **Cycle time shortened with faster acceleration**
- Work Weight Auto Setting estimates the weight of the workpiece and fixture on the table and automatically sets the linear axis servo parameters, including acceleration, to the optimum values. Cycle times are shortened with no changes to machining accuracy.

#### Rotary Axis Inertia Auto setting

- **Maintains high accuracy and stable movements**
- The "ServoNavi Rotary Axis Inertia Auto Setting" estimates the inertia of the workpiece and jig from the acceleration torque, and automatically sets the optimum servo parameters for the table rotation axis, including acceleration, thereby maintaining the high-precision operation of the table rotary axis. Moreover, the table indexing time for light weight workpieces is reduced.

### Cycle time reduction

Significantly shortens cycle times and reduces power consumption

- **Operation time reduction:** The non-cutting time is shortened by simultaneously performing multiple operations, such as spindle rotation and axis feed, and allowing the rotary axis to take the shortest path.
- **Machining time shortening:** The cycle time is reduced for parts machining with frequent switches between cutting feed and rapid traverse by using feeder-mode high-speed switching and optimal acceleration/deceleration.
- **Easy parameter setting:** Collects parameters related to cycle time reduction in a single screen for enabling changes and reuse in a single operation.

Parameter easy setting  
Setting screen

## Machining Navi M-i, M-gII+ (option)

Cutting condition search for milling

Longer tool life and shorter machining times by optimizing cutting conditions

### Searches for the best cutting conditions

- Machining Navi M-i changes automatically to optimum spindle speed
- Machining Navi M-gII+ displays several spindle speed possibilities

Changing to optimum spindle speed

Changing spindle speed

Lower cutting load required

## Machine Specifications

	Item	Unit	MA-8000H
Travels	X-axis (column left/right)	mm (in)	1,400 (55.12)
	Y-axis (spindle up/down)	mm (in)	1,200 (47.24)
	Z-axis (table front/back)	mm (in)	1,350 (53.15)
	Spindle center to pallet top	mm (in)	100 to 1,300 (3.94 to 51.18) {70 to 1,270 (2.76 to 50.00)} <30 to 1,230 (1.18 to 48.43)>
	Spindle nose to pallet center	mm (in)	100 to 1,450 (3.94 to 57.09)
Pallet	Work area	mm (in)	800 × 800 (31.50 × 31.50) <1,000 × 1,000 (39.37 to 39.37)>*1
	Max load capacity	kg (lb)	2,000 (4,400) [3,000 (6,600)]*2 <2,550 (5,610)>*2
	Indexing angle	deg	1 [0.001]
	Max workpiece dimensions	mm (in)	∅1,450 × 1,450 (∅57.09 × 57.09) {∅1,450 × 1,420 (∅57.09 × 55.91)} <∅1,450 × 1,380 (∅57.09 × 54.33)>
Spindle	Speed	min <sup>-1</sup>	50 to 6,000 [50 to 10,000, 50 to 12,000, 50 to 6,000 (high-torque spindle)]
	Tapered bore		7/24 taper No. 50 [HSK-A100]
	Bearing dia	mm (in)	∅100 (∅3.94)
Feed rate	Rapid traverse	m/min (ipm)	X, Y, Z: 50 (1,969)
	Cutting feed rate	mm/min (ipm)	X, Y, Z: 1 to 50,000 (0.04 to 1,969)
Motors	Spindle	kW (hp)	30/22 (40/30) (10 min/cont) [10,000 min <sup>-1</sup> : 45/30 (60/40) (20 min, 60 %ED/cont), 12,000 min <sup>-1</sup> : 45/30 (60/40) (10 min, 25 %ED/cont), 6,000 min <sup>-1</sup> high-torque spindle: 45/37 (60/50) (20 min/cont)]
	Feed axes	kW (hp)	X: 5.1 (6.8), Y: 3.5 (4.67) × 2, Z: 5.1 (6.8)
	Table indexing	kW (hp)	4.6 (6.13)
ATC	Tool shank		MAS403 BT50 [CAT50, DIN50, HSK-A100]
	Pull stud		MAS2 [MAS1, CAT, DIN, JIS]
	Magazine capacity	tools	60 [40 (chain magazine type)] [81, 111, 141, 171, 195, 225, 255, 285 (matrix magazine type)] [320, 400 (multiple magazine system)]
	Max tool dia (w/ adjacent)*3	mm (in)	∅140 (∅5.51)
	Max tool dia (w/o adjacent)*3	mm (in)	∅240 (∅9.45) [∅315 (∅12.40)]*4
	Max tool length	mm (in)	600 (23.62) [800 (31.50)]*4 *5
	Max tool mass	kg (lb)	25 (55) [30 (66)]*4
	Tool selection		Memory random [Matrix magazines use fixed addresses]
Machine size	Height	mm (in)	3,442 (135.51)
	Floor space; width × depth	mm (in)	3,960 × 8,178 (155.91 × 321.97)*6
	Mass	kg (lb)	33,000 (72,600)*7
Controller			OSP-P500M

[ ]: Option { }: T-slot millimeter pallet < >: 1,000 × 1,000 mm pallets (available only with two-sided rotary APC)

\*1. During APC rotation, a 110 mm Z-axis retraction is required (when using touch or laser sensors).

\*2. The special maximum loading capacity is supported only by the two-sided rotary APC and results in longer operation time.

\*3. Values differ with a matrix magazine. Please inquire.

\*4. Shutter open/close times become longer with the optional specification.

\*5. Max workpiece diameters may be limited by required tool lengths.

\*6. Off-machine chip discharge; hinge + scraper with drum filter.

\*7. Workpieces and tools not included.

## MA-8000H Standard Specifications

Spindle speed	No. 50	6,000 min <sup>-1</sup> (30/22 kW [10 min/cont])	APC fork washer	
ATC magazine capacity		60 tools	Air filter and oiler	
Spindlehead cooling system			Telescopic cover	
Ball-screw cooler		X-Y-Z axes	Hydraulic unit	
Centralized lubrication		Tank: 20 L	Automatic 1° indexing table	
		Oil level alarm and pressure alarm	2-pallet rotary-shuttle APC	Pallet top surface M16 tap
Coolant supply system		Tank: 1,293 L ( Dirty tank: 1,168 L (effective: 800 L ) Clean tank: 125 L )	Full enclosure shielding	2-pallet pivoted type for APC
		Pump: 3.0 kW, 1.5 kW, 0.55 kW (50 Hz)/0.75 kW (60 Hz)	Operation panel	15 in; movable (swivel, horizontal)
			ATC operation panel	For manual operation
In-machine chip discharge		Hinge type chip conveyor	NC (OSP) control cabinet ventilation fan	
Chip pan for above			Work lamp	LED (2 locations)
Coolant nozzle		Insert nozzle type	Status indicator	3 phase C type
Thru-spindle coolant*		1.5 MPa	Foundation blocks, jack bolts	
Suction of excess coolant in spindle			Slip stoppers and chemical anchors	
ATC air blower (blast)			Tool release lever	
Chip air blower (blast)		Nozzle type	Tapered bore cleaning bar	
Coil conveyor under APC			Hand tools	
In-machine chip washer			Tool box	
			TAS-S	Thermo Active Stabilizer – Spindle
			TAS-C	Thermo Active Stabilizer – Construction

\* Okuma pull stud required with Thru-Spindle Coolant.

## MA-8000H Optional Specifications

Spindle speeds	No. 50	50 to 10,000 min <sup>-1</sup> , 45/30 kW	Oil mist lubricator	
		50 to 12,000 min <sup>-1</sup> , 45/30 kW	Mist collector	
High-torque spindle	No. 50	6,000 min <sup>-1</sup> , 45/37 kW, 1,071 N·m	Coolant system	Sludgeless Tank (option)
Dual contact spindle*1		HSK*2, BIG-PLUS*3	In-machine chip discharge	Scraper type chip conveyor
ATC magazine capacity (tools)		40 tools (chain magazine type)	Off-machine chip discharge (lift-up chip conveyor types)	Refer to Recommended chip conveyors.
		81, 111, 141, 171, 195, 225, 255, 285 tools (matrix magazine type)	Chip bucket for above	Height 700 mm, 1,000 mm
		320, 400 tools (multiple magazine system)	Hydraulic oil cooler	
ATC maximum tool dimensions		∅315 mm, length 800 mm	Coolant heater / cooler	
Maximum weight		30 kg	Auto tool length comp / breakage detection	Touch sensor
AbsoScale detection		X-Y-Z axes	Auto zero offset/auto gauging	Touch probe
Auto 0.001° indexing table		Built-in NC table	Tool life management	By hour meter
Pallet loading capacity		3,000 kg (only with two-sided rotary APC)	Turn-Cut	AbsoScale detection required
APC Auto pallet changer*3		Parallel shuttle: 6P, 10P	Pull stud bolt shape	MAS1, CAT, DIN, JIS
FMS 2-pallet APC		Wing block type, Under-pallet fork type	Pull stud bolt	MAS1, MAS2, CAT, DIN, JIS
Pallet size		1,000 × 1,000 mm (only with two-sided rotary APC)	2-sided tooling block	
Pallet top surface configuration		T-slot	4-sided tooling block	
Spare pallets			Additional work lamp	
Edge locator			Machining Navi	M-i, M-gII+
Oil-hole coolant system		1.5 MPa	Hydraulic fixture systems	Linked, pallet-thru types
Thru-spindle coolant*4		7.0 MPa, large flow 1.5 MPa, large flow 7.0 MPa	Recommended for die machining	AbsoScale detection (X-Y-Z axes) Hyper-SurfaceII DNC-DT, 0.1 μm control
Semi-dry machining		Thru-spindle type, nozzle type, thru-spindle/nozzle switch type		
Shower coolant		10 nozzles		
Workpiece wash gun				

\*1. Be sure to select this specification when BIG-PLUS® holder is used.

\*2. Use HSK holders equipped with coolant supply pipes.

\*3. Excludes models with 3,000 kg loading capacity and 1,000 × 1,000 mm pallets.

\*4. Okuma pull stud required with Thru-Spindle Coolant.

**Chip conveyors** (Please contact an Okuma sales representative for details.)

○: recommended  
△: conditionally recommended

Workpiece Material		Steel	Cast iron	Aluminum/ non-ferrous metal	Mixed (general use)
Chip shape					
In-machine chip discharge	Hinge type (standard)*1	○	○	○	○
Off-machine chip discharge (option)*2	Hinge + scraper with drum filter (recommended)	○	○	○	○
	Hinge type	○	—	—	—
	Scraper type*3	—	○ (dry)	—	—
	Scraper type with drum filter*3	—	○ (wet) with magnet	△	—

\*1. Scraper type (option) also available. \*2. With limitations per conveyor discharge direction. \*3. When chips are shorter than 100 mm

**Off-machine lift-up chip conveyors**

Type	Hinge + scraper with drum filter	Hinge	Scraper	Scraper with drum filter
Shape				

Note: It is necessary to select a chip conveyor with hinge + scraper (with drum filter) if Sludgeless Tank option is chosen.

**A next-generation CNC OSP-P500M standard specifications**

Basic specs	Control	X, Y, Z, simultaneous 3 axis, spindle control (1 axis)
	Position feedback	OSP full range absolute position feedback (zero-point return not required)
	Coordinate functions	Machine coordinate system (1 set), work coordinate system (20 sets)
	Min/max command	±99999.999 mm, ±9999.9999° 8-digit decimal, command units: 0.001 mm, 0.01 mm, 1 mm, 0.0001°, 0.001°, 1°
	Feed	Cutting feed override: 0 to 200%
	Spindle control	Direct spindle speed commands, override 30 to 300%, multi-point indexing
	Tool compensation	No. of registered tools: Max 999 sets, tool length/radius compensation: 3 sets per tool
	Display	15-inch color LCD + multi-touch panel operations
	Security	Operator authentication, Lock screen, OSP-VPSII-STD (Virus Protection System)
	Programming	Program capacity
Program operations		Scheduled program, fixed cycle, G/M code macros, arithmetic, logic statements, math functions, variables, branch commands, Coordinate calculate, area machining, coordinate convert, programming help, user task, keyway cycle
Operations		OSP suite "suite apps" to graphically visualize and digitize information needed on the shop floor, "suite operation" enable one-touch access to "suite apps".
Easy Operation	Easy Operation	"Single-mode operation" to complete a series of operations. Advanced operation panel/graphics facilitate smooth machine control
	MacMan plus	Machining management: aggregation and display of machining records, operating records and problem information, Visualization of power consumption, file output
	Machine operations	Operation help, load meter, alarm help, sequence return, manual interrupt/auto return, pulse handle overlap, parameter I/O, PLC monitor, auto power shut-off
Communications / Networking	USB (2 ports), Ethernet, DNC-T1, Smart I/F	
High speed/accuracy specs	Thermo Active Stabilizer – Spindle (TAS-S), Thermo Active Stabilizer – Construction (TAS-C), Hi-Cut Pro, Pitch error compensation, Hi-G control, ServoNavi, Cycle time reduction (operation time reduction, machining time shortening, easy parameter setting)	
Energy-saving function	ECO suite plus	ECO Idling Stop, ECO Operation, oil temperature controller auto control, ECO Power Monitor
	Power Regeneration System	Regenerative power is used when the spindle and feed axes decelerate to reduce energy waste.

**A next-generation CNC OSP-P500M kit specifications/optional specifications**

Item	Kit specs	NML		AOT		DT		DT AOT	
		E	D	E	D	E	D	E	D
<b>Digital Twin</b>									
Virtual Machining						●	●	●	●
Quick Modeling						(VE)	(VD)	(VE)	(VD)
OPC UA for Machine Tools						(VE)	(VD)	(VE)	(VD)
OSP API KIT						●	●	●	●
<b>Interactive functions</b>									
Advanced One-Touch IGF-M (w/ Real 3-D simulation)				●	●			●	●
Interactive MAP (I-MAP)								●	●
Smart OSP Operation				●	●	●	●	●	●
<b>Programming</b>									
Operation buffer 10 MB		●	●	●	●	●	●	●	●
Program notes (MSG)		●	●	●	●	●	●	●	●
Auto scheduled program update		●	●	●	●	●	●	●	●
Block skip; 9 sets									
Program branch; 9 sets									
Coordinate system select (Std: 20 sets)	100 sets	●	●	●	●	●	●	●	●
	200 sets			●	●	●	●	●	●
	400 sets								
Helical cutting		●	●	●	●	●	●	●	●
3-D circular interpolation									
Skip									
Synchronized Tapping II		●	●	●	●	●	●	●	●
Arbitrary angle chamfering		●	●	●	●	●	●	●	●
Cylindrical side facing									
Tool max rotational speed setting									
F1-digit feed	External switch type, parameter type								
Programmable travel limits (G22, G23)		●	●	●	●	●	●	●	●
Slope machining	Type I, Type II								
Axis name designation									
Fixture offset II									
Dynamic fixture offset									
Tool grooving									
Turn-Cut									
Dynamic Tool Load Control									
3-D tool compensation									
Coordinate change and drawing conversion	Programmable mirror image (G62)	●	●	●	●	●	●	●	●
	Enlarge/reduce (G50, G51)	●	●	●	●	●	●	●	●
User task	Common variables 1,000, 2,000 pcs								
	G code macros: 80 sets added								
	I/O variables (16 each)								
Sequence stop		●	●	●	●	●	●	●	●
Sequence return	Mid-block sequence return	●	●	●	●	●	●	●	●
Tool wear compensation	Includes input restriction	●	●	●	●	●	●	●	●
Tool life management	Includes warning	●	●	●	●	●	●	●	●
<b>Gauging</b>									
Auto tool length offset/breakage detection									
In-magazine tool breakage detection									
Auto Workpiece Gauging/Auto zero offset									
Manual gauging (w/o sensor)		●	●	●	●	●	●	●	●
Interactive gauging (touch sensor, touch probe required)									
<b>External I/O communication</b>									
RS-232C connector									
DNC connection	DNC-T3, DNC-B, DNC-DT DNC-C/Ethernet								
<b>Monitoring</b>									
21.5-inch color LCD operation panel tilt adjustment									
One-Touch Spreadsheet									
Collision Avoidance System									
Real 3-D Simulation						●	●	●	●
Simple load monitor	Spindle overload monitor	●	●	●	●	●	●	●	●
NC operation monitor	Hour meter, workpiece counter	●	●	●	●	●	●	●	●
Status indicator									
Operation end buzzer									
Workpiece counters on machine									
Tool breakage no-load detection		●	●	●	●	●	●	●	●
MOP-TOOL	Adaptive control, overload monitor								
AI machine diagnostics*	Spindle/feed axes, or feed axes only								
Machine Status Logger									
Cutting Status Monitor									
Machining Navi M-i, M-gII+(cutting condition search)									
Feed axis retraction									
Tool retract cycle									
<b>Automation / Unattended operation</b>									
Warm-up (calendar timer)									
External program	Button, rotary switch Digital switch, BCD (2-digit, 4-digit)								
Pallet pool control (PPC) (Required for multi-pallet APC)									
Connection with automated devices	Robot, loader I/F Stacker crane I/F FMS link I/F								
<b>High-speed, high-precision</b>									
AbsoScale detection	X-Y-Z axes								
Dynamic displacement compensation		●	●	●	●	●	●	●	●
0.1 μm control (linear axis commands)									
Hyper-SurfaceII	3 linear axes, 3 linear axes + 2 rotary axes								
<b>ECO suite plus</b>									
ECO Power Monitor	On-machine wattmeter								
Spindle Power Peak Limiter									
Energy-saving hydraulic unit	ECO Hydraulics								
External output interface of consumed electricity									
<b>Other</b>									
Circuit breaker									
OSP-VPSII-EX (Virus Protection System)									
Pulse handles	2 pcs, 3 pcs								
External M codes [4 sets, 8 sets]									

Note 1. NML: Normal kit, AOT: Advanced One-Touch IGF-M kit, DT: Digital Twin kit, DT AOT: Digital Twin Advanced One-Touch IGF-M, E: Economy, D: Deluxe  
VE and VD kits are also equipped with the Digital Twin on PC function, allowing running from a PC.  
Note 2. Specifications, etc. are subject to change without notice.  
\* With AbsoScale detection specs, ball-screw wear detection is possible.



When using Okuma products, always read the safety precautions mentioned in the instruction manual and attached to the product.

● The specifications, illustrations, and descriptions in this brochure vary in different markets and are subject to change without notice.  
Pub.No. MA-8000H-E-(3a)-100 (Jun 2025)

This product is subject to the Japanese government Foreign Exchange and Foreign Trade Control Act with regard to security controlled items; whereby Okuma Corporation should be notified prior to its shipment to another country.



**OKUMA Corporation**

Oguchi-cho, Niwa-gun,  
Aichi 480-0193, Japan  
TEL: +81-587-95-7825 FAX: +81-587-95-6074