

***MB-80V***  
***MB-100V***

Vertical Machining Centers



Vertical Machining Centers

# MB-80V/MB-100V



## User-friendly yet extremely precise, – easing large-part machining burden

The MB-80V/MB-100V are powerful, high-precision vertical machining centers built with a double-column structure and are able to machine large workpieces with ease.

Also, its space-saving design contributes to saving floor space in the factory.

High-power machining reduces machining time, and the machine is equipped with unique technology that allows it to autonomously maintain high precision and achieve high-precision machining.

The machine construction takes into consideration setup work for large parts, and it is equipped with a large stroke and solutions for multi-sided machining, minimizing the operator's workload.

Furthermore, it smoothly discharges the large amount of chips that are generated, thoroughly eliminating chip troubles that can cause machining to stop.

The MB-80V/MB-100V is user-friendly and exacting in its precision, achieving stable operation over long periods of time while minimizing operator intervention in dimensional control and chip removal, improving productivity in machining large parts.



MB-80V

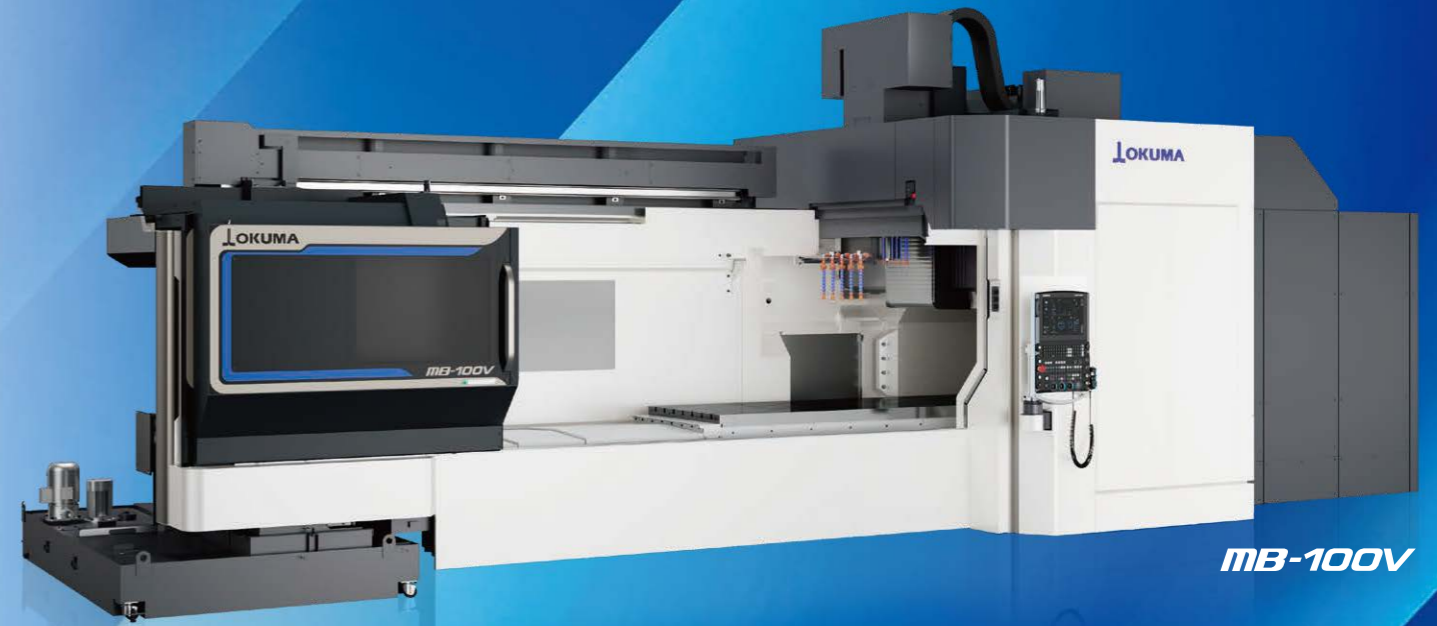

MB-100V



Semiconductor manufacturing equipment components  
Cooling plate

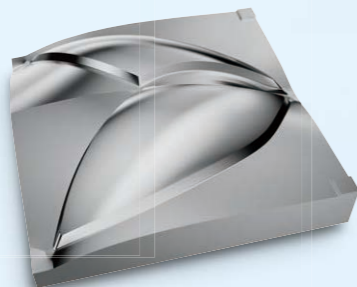

Automobile headlight cover  
plastic dies/molds



Automobile dash panel  
press dies/molds

Photographs and images used in this brochure may include optional equipment.

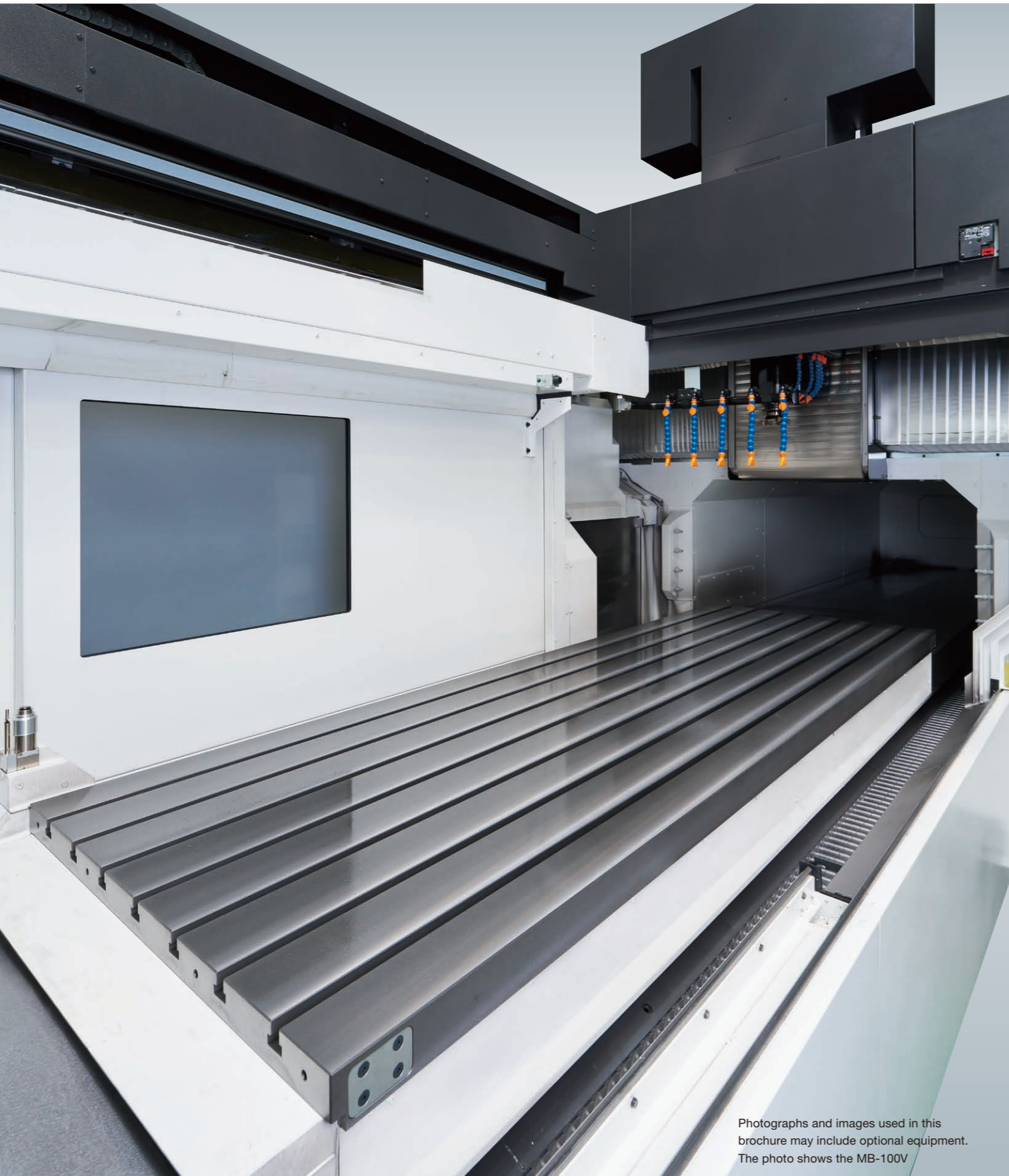

Photographs and images used in this brochure may include optional equipment. The photo shows the MB-100V

## Achieves large part machining in a small space

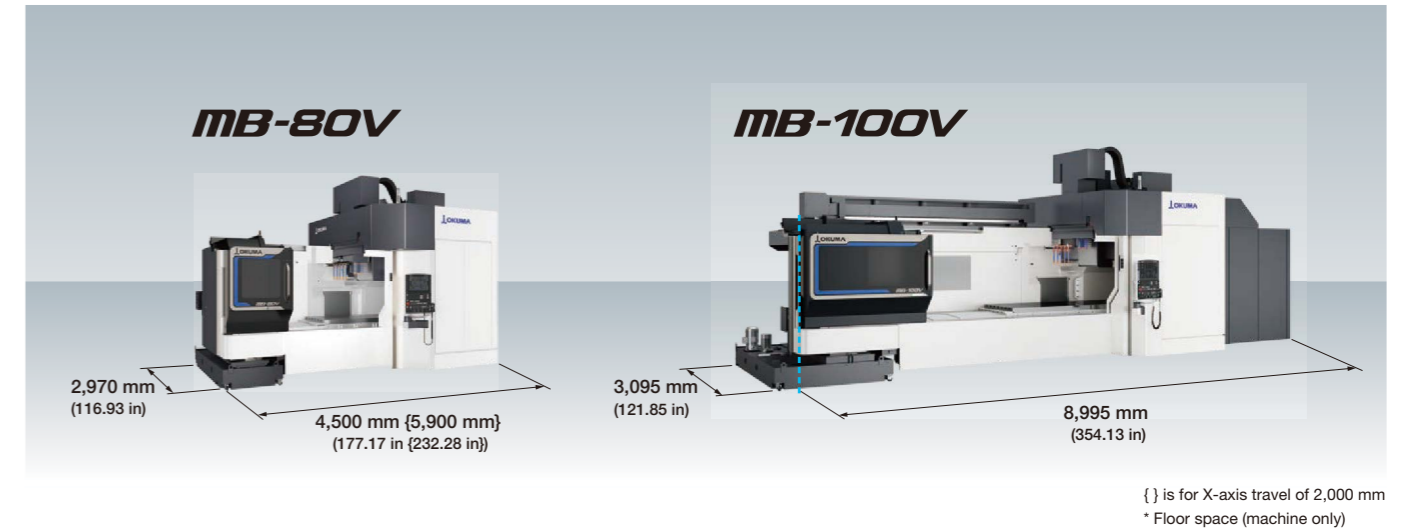

## Ample machining area for large parts

The machine has a large table and working range that are sufficient for machining large parts for a wide range of industries, including semiconductor manufacturing equipment components, construction machinery, and dies/molds. It employs a highly rigid double-column construction and a space-saving design, achieving the best area productivity in its class.

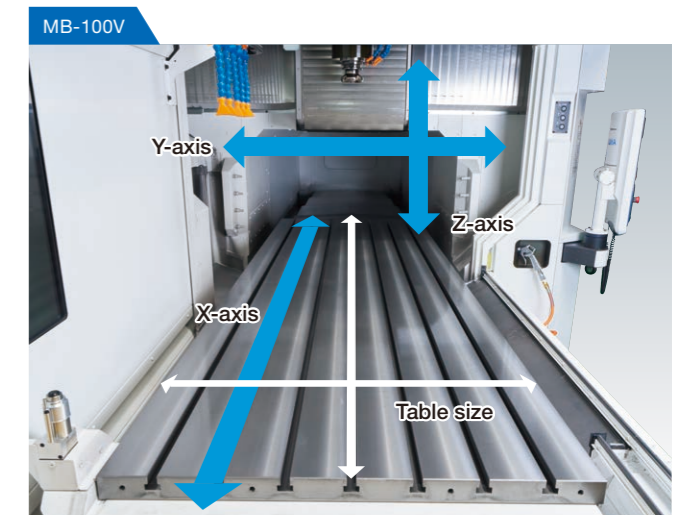
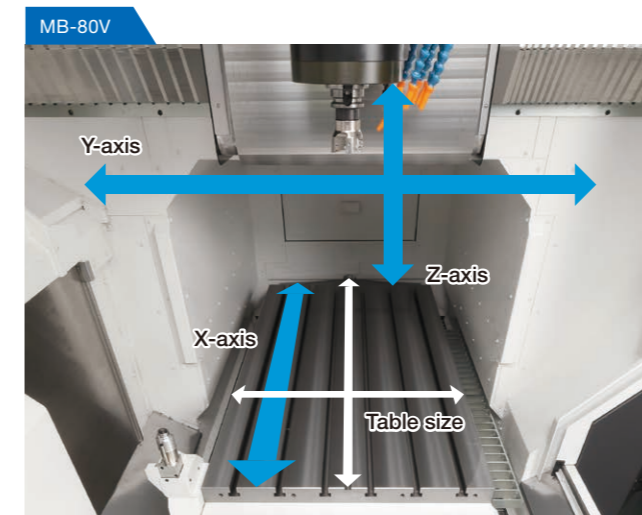

		MB-80V	MB-100V
Table size	mm (in)	1,600 × 800 {2,000 × 800} (62.99 × 31.50 {78.74 × 31.50})	3,000 × 1,000 (118.11 × 39.37)
X-axis travel	mm (in)	1,600 {2,000} (62.99 {78.74})	3,200 (125.98)
Y-axis travel	mm (in)	1,050 (41.34)	1,250 (49.21)
Z-axis travel	mm (in)	600 {750} (23.62 {29.53})	750 (29.53)
Max load capacity	kg (lb)	2,500 [4,000: option] (5,500 [8,800: option])	6,000 [8,000: option] (13,200 [17,600: option])

{ } is for X-axis travel of 2,000 mm < > is for Z-axis travel of 750 mm

Outstanding dimensional stability greatly shortens compensation and warm-up

**Reliable machining with high accuracy and excellent thermal stability**



**Thermo-Friendly Concept**

The Okuma Intelligent Technology that enables machines to autonomously maintain high accuracy stability

The Thermo-Friendly Concept is to achieve amazing machining accuracy with unique structural design and thermal deformation control technology. It eliminates the need for cumbersome dimensional compensation and warm-up and demonstrates outstanding dimensional stability, even when operation continues over many hours or when the ambient temperature in the factory changes.

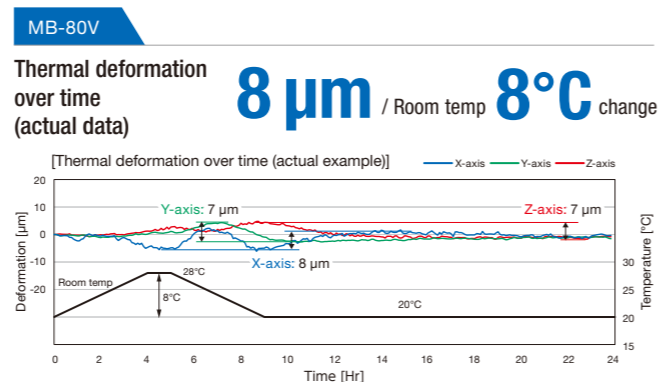

\* The data listed in the catalog are actual data and does not guarantee accuracy.

**Eliminate waste with the Thermo-Friendly Concept**

Okuma's Thermo-Friendly Concept achieves high dimensional stability not only when the room temperature changes, but also at machine startups or when machining is resumed. The warm-up operation time to stabilize thermal deformation is shortened, and the burden of dimensional correction when resuming machining is reduced.

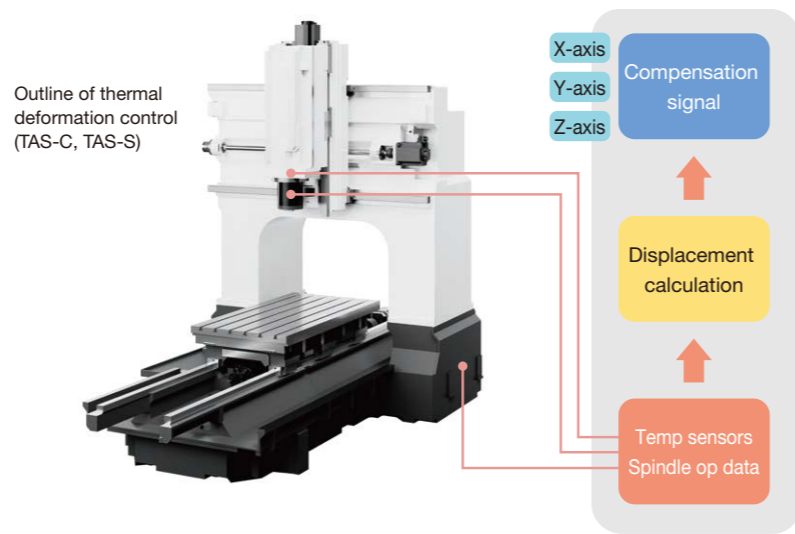
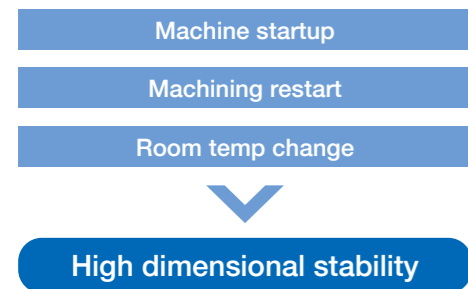

**TAS-C** Thermo Active Stabilizer - Construction

TAS-C, based on machine thermal characteristics, with appropriately placed temperature sensors and feed axis position data, will predict and accurately control thermal deformation in machine construction when ambient temperatures change.

**TAS-S** Thermo Active Stabilizer - Spindle

TAS-S considers not only spindle temperature information but also spindle rotation, spindle speed changes, and spindle stoppage. Thermal deformation of the spindle is accurately controlled even when spindle speed changes frequently.

time and improves productivity

**Maintains stable machine accuracy over a long period of time**

**3D Smart Calibration System**

Calibrates the spatial accuracy of the machine

option

**Anyone can easily calibrate machine accuracy**

Factory floors undergo deformation over the long term, which affects the accuracy of machines. 3D calibration inspects and calibrates machine accuracy (positioning accuracy, straightness, squareness) by automatically measuring an accuracy master, which serves as an absolute accuracy standard, using a simply-operated touch probe.

**The machine notifies you of the timing for accuracy calibration**

The accuracy stability diagnosis function estimates changes in machine accuracy due to thermal deformation of the floor or uneven factory temperatures, and quantifies them as "accuracy stability." By performing 3D calibration at the timing notified by the accuracy stability diagnosis function, high accuracy can be maintained over the long term across the entire machining space.



Linear axis error measurement using the accuracy master (ball beam) and touch probe

**Reliable machine structure that achieves machining with high accuracy and high efficiency**

**Reliable, highly rigid double-column construction**

The highly rigid double-column construction that has a small overhang from the guideway of the linear axis to the machining points adopted. The casting design optimizes the flow of loads that need to be supported, resulting in a lean and reasonable structure that enables high rigidity.

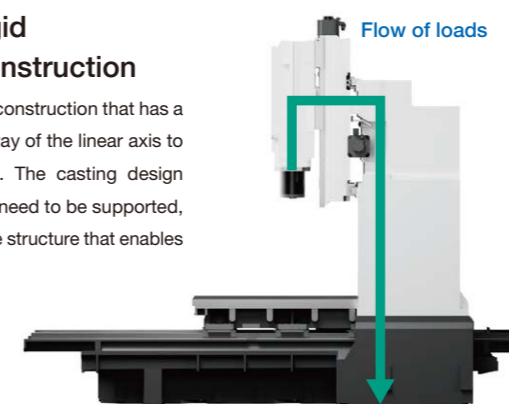

**Simple machine construction for thermal deformation / Machine designs that equalize heat transmission**

"Manageable deformation"—structural designing for controlled machine expansion/contraction (predictable directions), with equalized heat transmission.

**Enhanced Thermo-Friendly Concept**

We pursued the machine structure suppresses tilting due to temperature changes on the cover side and the outside in order to ensure that the heat capacity of the machine structure is well-balanced. As a result, machining accuracy is further increased.

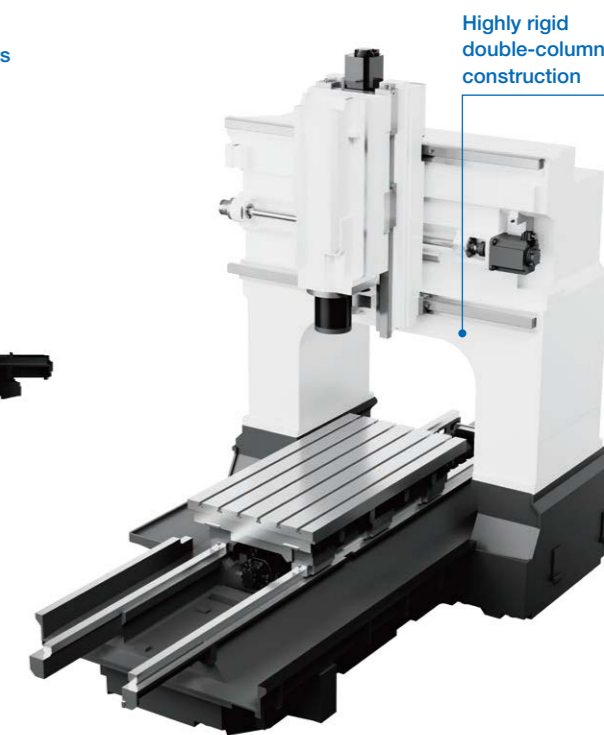

# High productivity Increase productivity by shortening machining time

A wide range of spindle lineups suitable for machining general parts, dies/molds,

## The spindle lineup

For a wide range of machining, from steel materials to aluminum materials

**MB-80V standard spindle**  
Wide-area spindle No. 40

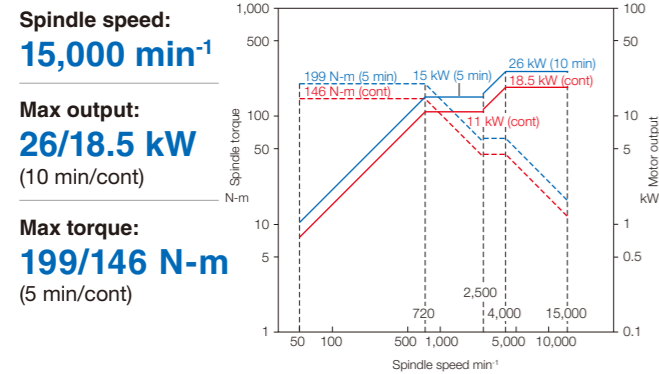

\* MB-100V: option

Material : S45C actual data

**Cutting Capacity 400 cm<sup>3</sup>/min** (face milling)

Tool	Spindle speed min <sup>-1</sup>	Cutting speed m/min	Feed rate mm/min	Cutting width mm	Cutting depth mm
ø100 face mill, 5 blades (carbide)	955	300	1,429	70	4
Insert drill ø63	606	120	91	—	—
Tap M30P3.5	240	23	840	—	84% (spindle load)

\* MB-80V (No. 40) actual data

Material : A5052 actual data

**Cutting Capacity 1,500 cm<sup>3</sup>/min** (face milling)

Tool	Spindle speed min <sup>-1</sup>	Cutting speed m/min	Feed rate mm/min	Cutting width mm	Cutting depth mm
ø63 face mill, 5 blades (carbide)	15,000	2,969	8,523	44	4

\* MB-80V (No. 40) actual data

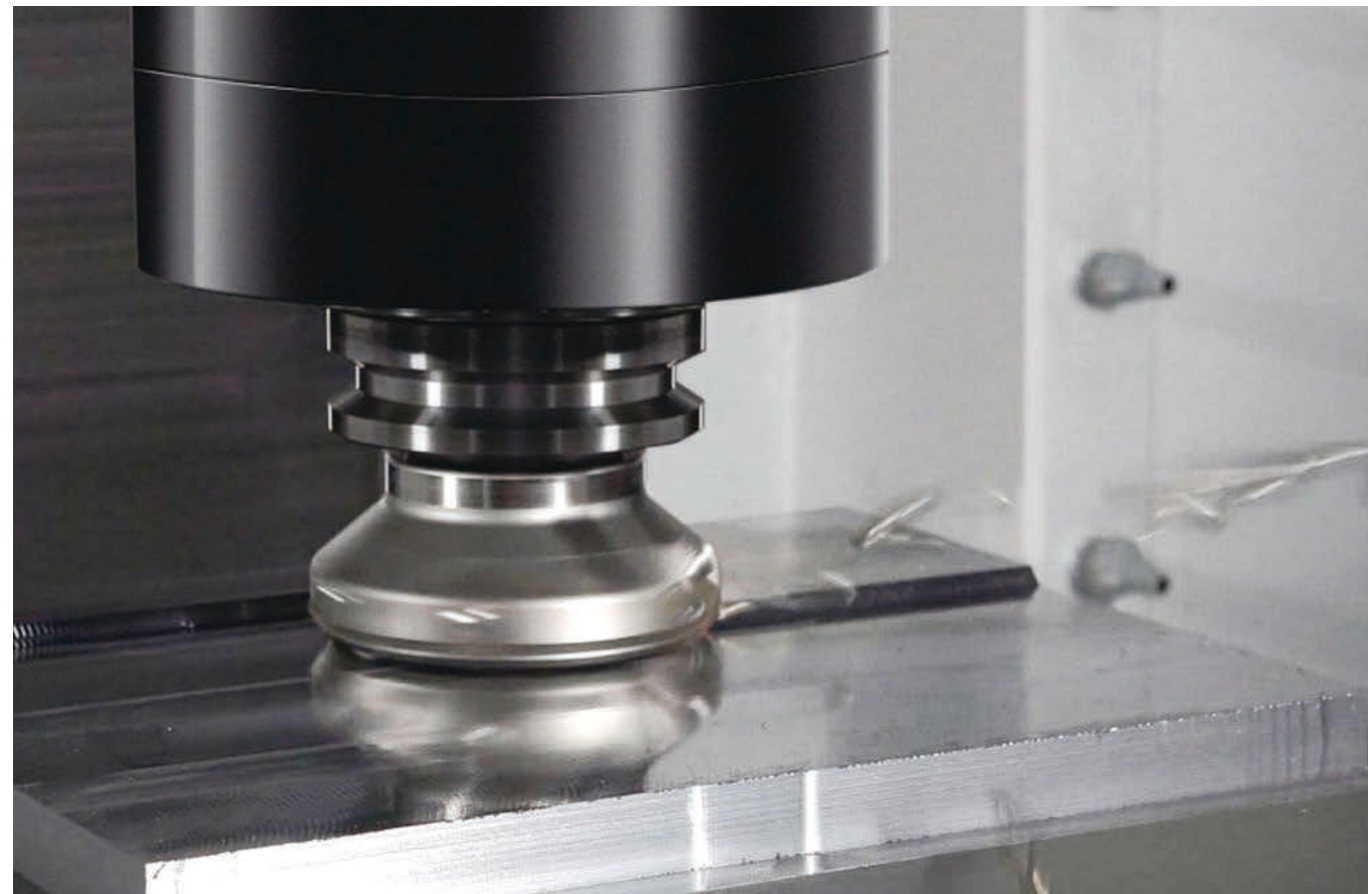

# with highly efficient machining

and aluminum materials

Complete machining from highly efficient machining of general parts to rough and finish machining of dies/molds

**MB-100V standard spindle (No.50)**  
High power spindle No. 40/No. 50 roller bearing specifications

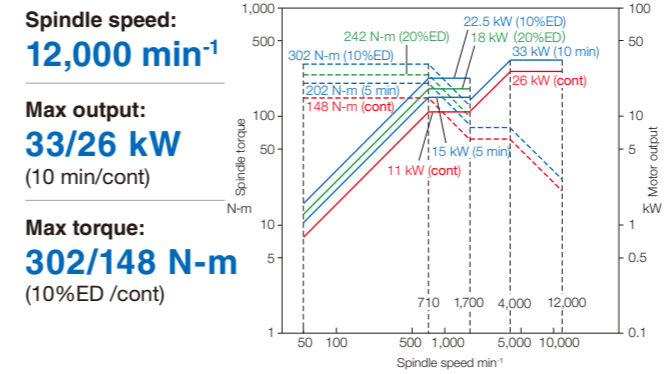

\* MB-80V: option

Material : S45C actual data

**Cutting Capacity 669 cm<sup>3</sup>/min** (face milling)

Tool	Spindle speed min <sup>-1</sup>	Cutting speed m/min	Feed rate mm/min	Cutting width mm	Cutting depth mm
ø100 face mill, 5 blades (carbide)	955	300	1,910	70	5

Material : S45C actual data

**Cutting Capacity 704 cm<sup>3</sup>/min** (end milling)

Tool	Spindle speed min <sup>-1</sup>	Cutting speed m/min	Feed rate mm/min	Cutting width mm	Cutting depth mm
ø20 roughing end mill, 7 flutes (carbide)	4,000	251	9,520	3.7	20

For high speed machining, mainly of aluminum materials

**High-speed spindle No. 40 (option)**

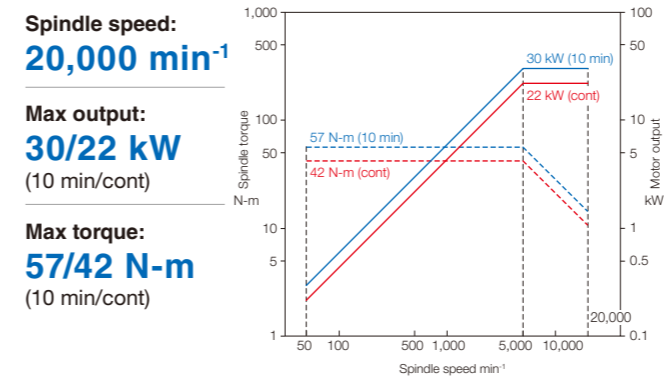

Note: The "actual data" referred to above for this brochure represent examples, and may not be obtained due to differences in specifications, tooling, cutting condition, and others.



Smooth chip discharge ensures stable operation for long periods of time

**ATC structure that reduces the risk of breakdown**

By installing the ATC arm and cam box outside the machining chamber, problems caused by chip accumulation and chip entrapment are eliminated

**Dramatically reduces the amount of work required to clean workpieces and the interior of the machine**

**Cleaning by the shower installed under the crossrail** option

Cleaning by the shower installed under the crossrail (option) sweeps away chips from workpieces and the table



The photo shows the MB-80V

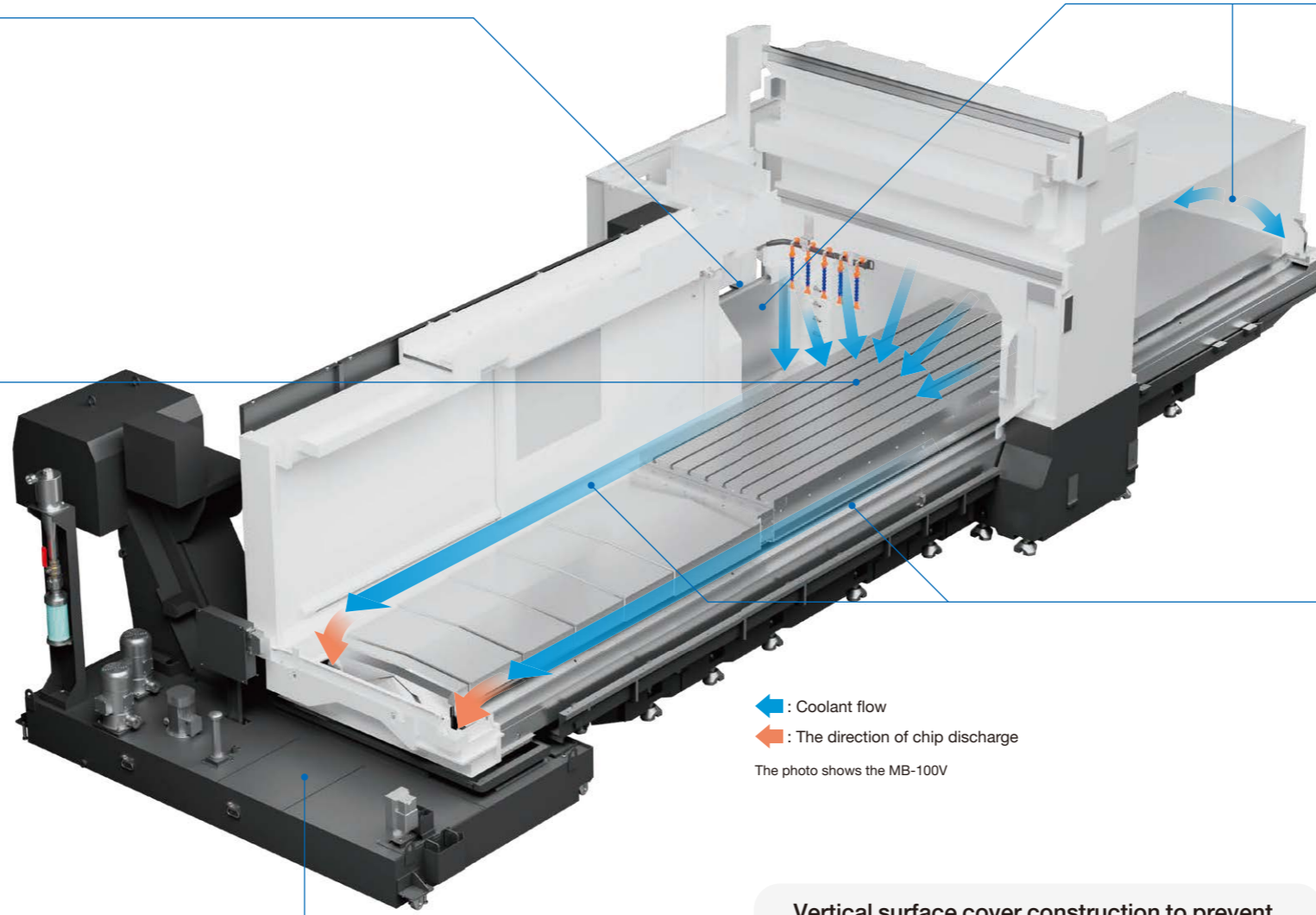

← : Coolant flow  
 → : The direction of chip discharge  
 The photo shows the MB-100V

**Cleaning inside the machine prevents chip accumulation inside the machine**

Effective pinpoint cleaning reduces chip accumulation and reduces the risk of breakdowns



The photo shows the MB-100V

**Large amounts of chips can be collected throughout the machine**

**Hinge-type in-machine conveyor**

Wide hinge-type in-machine conveyors are installed in front and behind the table. Large amounts of chips can be discharged smoothly

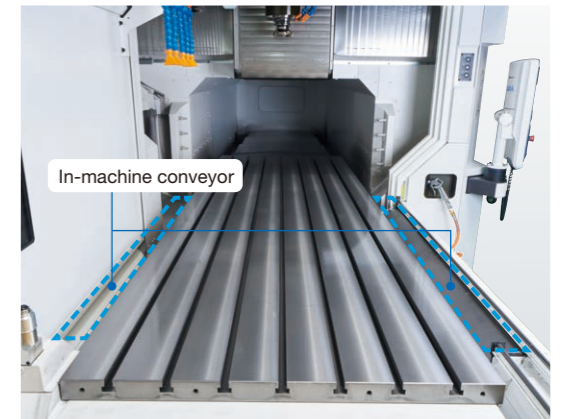

The photo shows the MB-100V

**Dramatically reduces the frequency of tedious tank cleaning**

**Sludgeless Tank** option

A Sludgeless Tank (option) is available to efficiently collect sludge. Greatly reduces maintenance work for coolant



Sludge and oil floating during long shutdowns

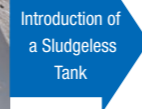

The stirring function virtually eliminates floating objects, sludge, and oil

**Vertical surface cover construction to prevent chips from accumulating inside the machine**

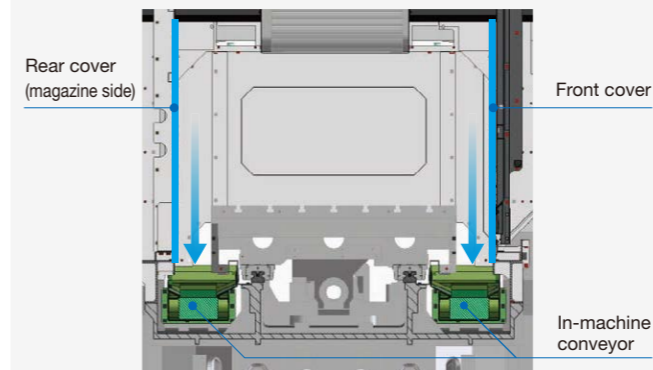

The figure shows the cross-sectional construction seen from the left side of the machine

Highly accurate and stable operation prevents long machine downtime

Improved, long-term machining accuracy and surface quality through optimized servo control



**SERVO NAVI**  
Optimized Servo Control

## Cycle time shortened with faster acceleration

### ■ SERVO NAVI AP (Automatic Parameter setting): Work Weight Auto Setting

On table travel type machining centers, the table feed acceleration with the previous system was the same regardless of weight, such as workpieces and fixtures loaded on the table. Work Weight Auto Setting estimates the weight of the workpiece and fixture on the table and automatically sets the linear axis servo parameters, including acceleration, to the optimum values. Cycle times are shortened with no changes to machining accuracy.

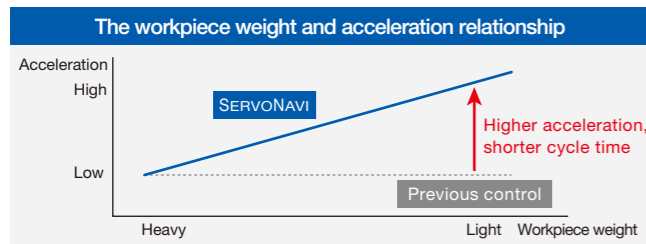

## Maintains machining accuracy and surface quality

### ■ SERVO NAVI SF (Surface Fine-tuning): Reversal Spike Auto Adjustment

Slide resistance changes with length of time machine tools are utilized, and discrepancies occur with the servo parameters that were the best when the machine was first installed. This may produce crease marks at motion reversals and affect machining accuracy (part surface quality). Reversal Spike Auto Adjustment maintains machining accuracy by switching servo parameters to the optimum values matched to changes in slide resistance.

## Contributes to longer machine life

### ■ SERVO NAVI SF (Surface Fine-tuning): Vibration Auto Adjustment

When aging changes machine performance, noise, vibration, crease marks, or fish scales may appear. Vibration Auto Adjustment can quickly eliminate noise and vibration even from machines with years of operation.

With predictive maintenance, prevent machine stoppages just in time



**AI Machine Diagnosis Function**  
Machine tool diagnostics technology with artificial intelligence (AI) option

Okuma's AI-equipped control detects abnormalities in the machine spindle and feed axes, leading to the prevention of long machine downtime and achieving stable production over a long period of time. The operators themselves can easily diagnose the machine by following simple screen guidelines on the Okuma control.

Notes:  
AI diagnostic models are already installed, and diagnoses can be performed by the machine itself.  
AI diagnostic models can be updated through Okuma's Connect Plan.  
AbsoScaLe detection specs is required for ball-screw wear detection.

### AI Spindle Diagnosis Function

Detects damage to spindle bearings

Self-diagnosis of spindle and feed axis status with AI

Axis	Acquisition date	Result
X	2023/02/11 16:36:45.240	Normal
Y	2023/02/11 16:31:45.472	Normal
Z	2023/02/11 16:28:35.512	Normal
X	2023/02/11 16:21:49.024	Normal
Y	2023/02/11 16:19:06.160	Normal
Z	2023/02/11 16:15:52.576	Normal
All	2022/11/13 11:31:10.112	Normal

Inspection results: **Normal**

Progress: 0% (Certainty: 96)

### AI Feed Axis Diagnosis Function

Detects damage to ball-screw support bearings

Detects ball-screw wear condition

Reduces operator intervention during machining, reducing the operator's workload

Coolant maintenance work is significantly reduced  
The environmental impact of coolant disposal is also minimized

## Sludgeless Tank option

The Sludgeless Tank continuously circulates cutting fluid within the tank, efficiently collecting sludge to prevent accumulation and significantly reducing issues and maintenance work. This significantly reduces the frequency of tank cleaning, enabling stable operation over long periods and improving productivity. It also extends the cutting fluid's lifespan, helps prevent spoilage and odors, and creates a better working environment. Furthermore, reducing the frequency of cutting fluid changes decreases industrial waste and lessens the environmental impact.

**Sludge removal rate** **99%** (when the material is casting and aluminum)  
Notes: After secondary filtration (cyclone filter) permeation  
Okuma evaluated removal rate

**No coolant tank cleaning required for 3 years**  
(Okuma equipment actual data)

**No coolant replacement required for 3 years**  
(Okuma equipment actual data)

Notes:  
It is necessary to select a chip conveyor with drum filter if the Sludgeless Tank option is chosen.  
Tank structure varies depending on the model and specifications.

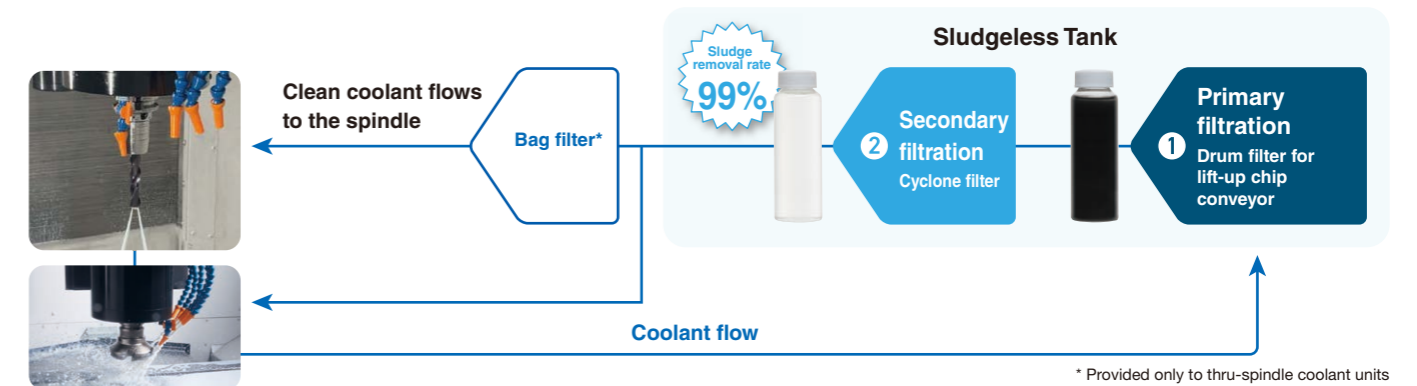
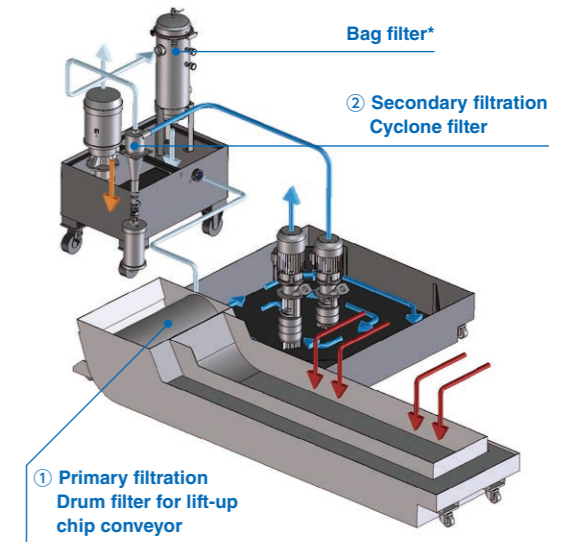

## Improved operating rate with auto pallet changer (APC)

Replacing large parts significantly reduces the operating rate. Off-machine setup using a two-sided APC improves the operating rate and extends unattended operating time. The two-sided APC is located on the side of the machine, and the layout allows work to be done from the operation panel side, reducing the operator's travel distance and reducing the workload.

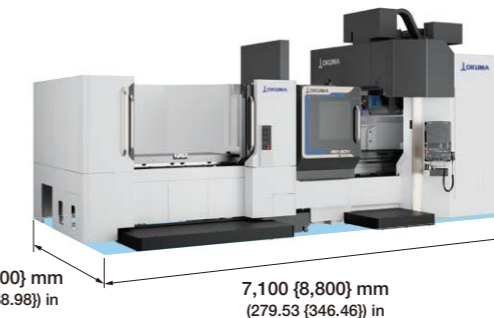

4,000 {4,800} mm  
(157.48 {188.98}) in

7,100 {8,800} mm  
(279.53 {346.46}) in

The floor space dimensions include 32 ATC magazines, the lift-up chip conveyor (discharge height: 750 mm), and the APC step platform.  
{ } is for X-axis travel of 2,000 mm

The shortest route between the setup station and the machine's operation panel

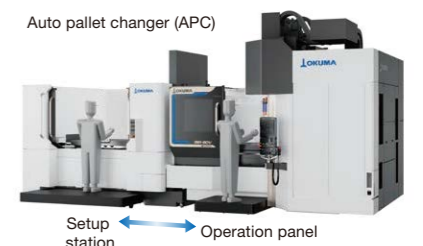

The image shows MB-80V

Shorter lead times by consolidating multiple processes into one machine. Further

## Consolidating side machining processes reduces the setup time and achieves high-precision machining

Angle head option

The angle head is equipped with a highly accurate indexing function, allowing machining from multiple directions without changeover, even for large workpieces where changing the machining position is difficult. Machining can be done with one chucking, which reduces the setup time and achieves high-precision processing. The angle head is compatible with the auto tool changer (ATC), allowing continuous machining of multiple processes without operator intervention.

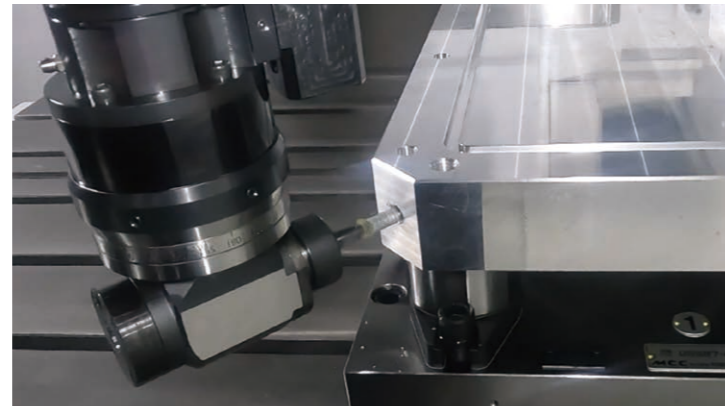

Machining from multiple directions is possible with the Y-axis travel larger than the table size

## Consolidating highly airtight and highly durable joining processes reduces costs and lead times

Friction stir welding (FSW) option

Friction stir welding (FSW) is a joining technology that uses frictional heat to soften, stir, and mix materials to integrate them into one body. FSW generally requires a dedicated machine, but the MB-80V/MB-100V has a highly rigid machine construction that allows it to be performed with a standard machine. It achieves high-quality joining that is both highly airtight and highly durable without the need for a dedicated machine, and also contributes to reducing capital investment costs and shortening lead times.

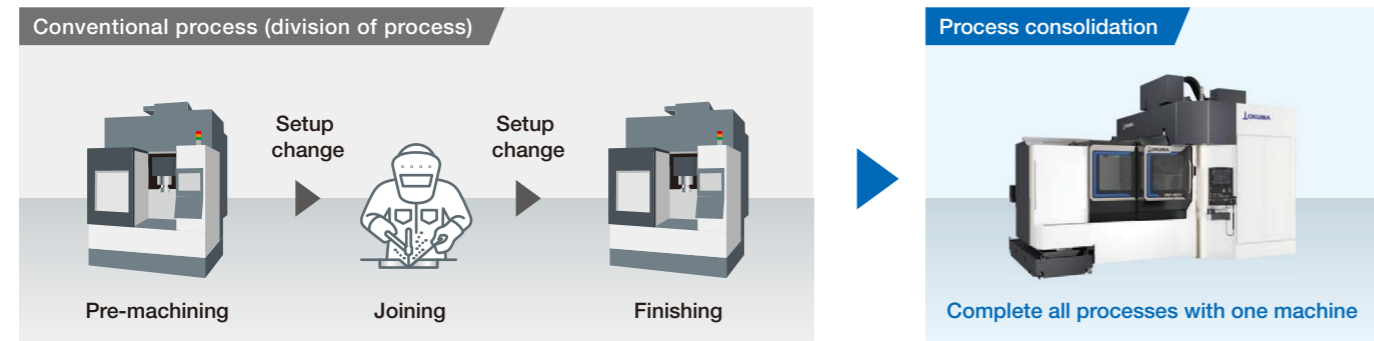

improvement of added value

## Achieves highly airtight seal grooving without a hand finishing process

Flat-Tool Grooving option

By finishing the groove bottom with a cutting tool, a highly sealed surface can be obtained that reduces fluid leakage. When grooves are machined with an end mill, cutter marks are left at the bottom of the groove, reducing airtightness and requiring hand finishing. However, with grooving using a cutting tool, the cutting edge phase and the direction of motion are precisely synchronized to create machining marks on the machined surface, allowing for smooth machining of even complex groove shapes with connected curves, thereby achieving high airtightness.



The cutting edge direction is controlled to match the groove

## Effortlessly and easily achieves high-precision quality control and reduces lead times

NC Gage option

Dimensions such as hole position and flatness, as well as geometric accuracy can be measured on the machine. There is no need to transport, load, or unload workpieces, or change setups for each measurement point, significantly reducing lead time. It has over 20 types of measurement functions, including geometrical tolerances and position dimensions, and measurement programs are automatically generated through intuitive teaching. Measurement results can be saved as a report and used for quality control.



## Anyone can easily calibrate machine accuracy

In-machine measurement automatic calibration function option

In-machine measuring devices such as touch sensors and touch probes can be calibrated automatically. Using a reference block or reference sphere, the zero point and correction values can be automatically calibrated, enabling high-precision measurements to be maintained stably for a long period of time without hassle and in a short time.

**No manual work required, significantly reducing calibration time**

Calibration time  
20 min → **2 min**



Touch sensor zero point calibration Touch probe length calibration Touch probe diameter calibration

# Various advanced technologies that increase productivity

## Okuma's advanced technology - effective for shop floors

### Allowing operators to focus on making parts without worrying about collisions, reducing machining preparation time



**Collision Avoidance System**  
Collision prevention option

The NC unit (OSP) has 3D model data of the machine construction and performs a real-time simulation prior to the actual machine operation. It checks for interference and collisions and stops machine operation just before a collision occurs, preventing collisions in all situations, whether the machine is operating in automatic or manual mode. It provides risk-free protection for the machine and great confidence for the operator.

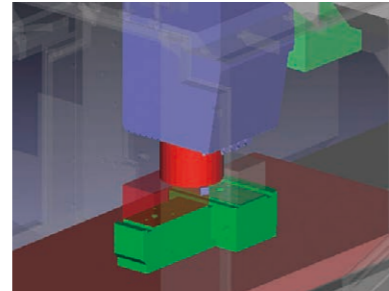

### Reduces costs and chatter vibration



**Machining Navi**  
Cutting condition search option

In case that chatter vibration occurs, the usual solution was to sacrifice productivity by lowering the cutting conditions, or to use costly special tools that are less likely to cause chatter vibration. Machining Navi instantly searches for the optimal cutting conditions and visualizes the cutting status, maximizing the capabilities of the machine and tools and improving productivity.

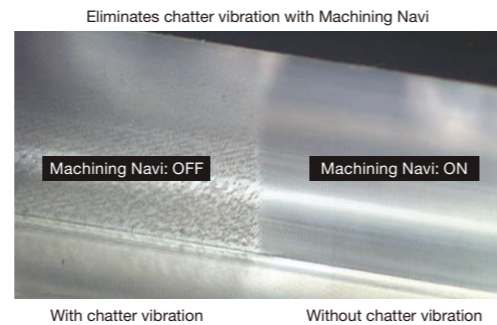

### Machining Navi M-i

(Optimization of spindle speed / Harmonic Spindle Speed Control (HSSC))

#### Automatically changes to optimum spindle speed

Chatter vibration is measured by built-in sensors, and Machining Navi automatically changes spindle speed to the optimum speed.

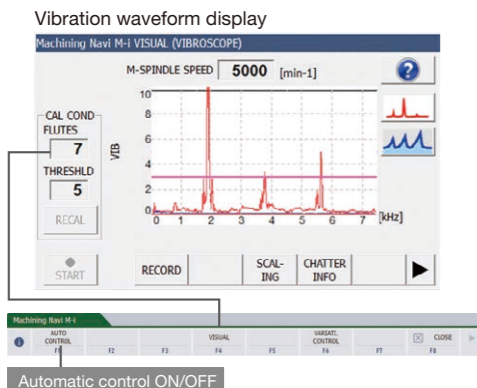

### Machining Navi M-gII+

(Optimization of spindle speed / Harmonic Spindle Speed Control (HSSC))

#### Adjust cutting conditions while monitoring the data

Based on the chatter noise captured by the microphone, Machining Navi displays a number of optimal spindle speed possibilities on the screen. The operator can change to the indicated spindle speed with a single touch and immediately confirm the result.

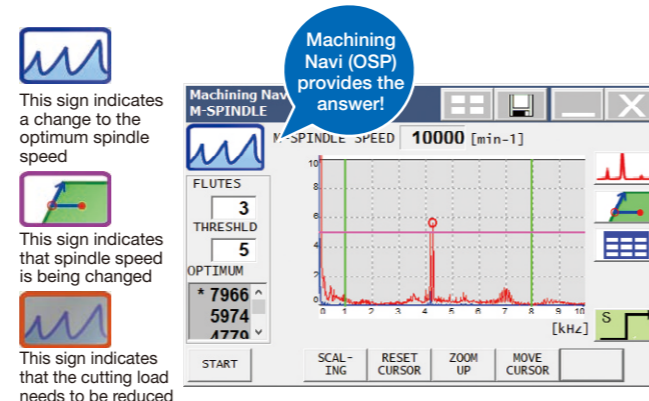

### Improving the performance of machining dies and free-form surfaces

**Hyper-Surface II** option

No modification of NC data is required. By reducing streaks and edge irregularities, machined part quality can be improved and hand finish polishing time can also be reduced. The Hyper-Surface function automatically compensates for edge positioning errors of the machining data output from CAM or the adjacent cutting path while maintaining shape accuracy. In addition, the SMART finish reduces vibration at corners without slowing down, reducing machining time and improving surface quality.

Notes: The effect varies depending on the machining shape.

#### Comparison of machined surface quality

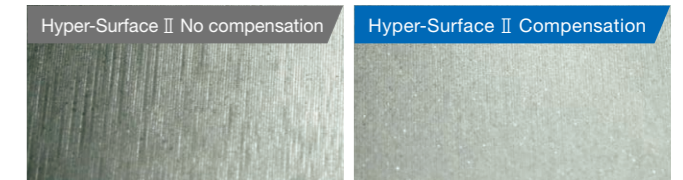

#### Smooths minor fluctuations and variations in command points

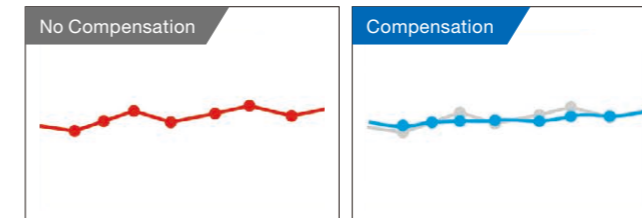

#### Adjust steps errors between adjacent cutter paths

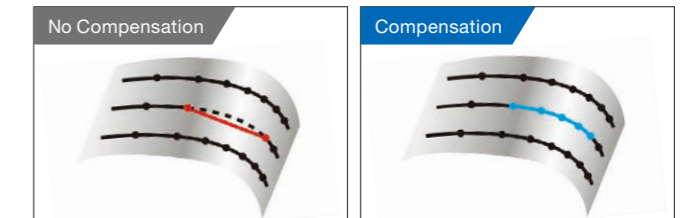

### Significantly shortens cycle times and reduces power consumption

#### Cycle time reduction

- Operation time reduction: The non-cutting time is shortened by simultaneously performing multiple operations, such as spindle rotation and axis feed, and allowing the rotary axis to take the shortest path.
- Machining time shortening: The cycle time is reduced for parts machining with frequent switches between cutting feed and rapid traverse by using feeder-mode high-speed switching and optimal acceleration/deceleration.
- Easy parameter setting: Collects parameters related to cycle time reduction in a single screen for enabling changes and reuse in a single operation.

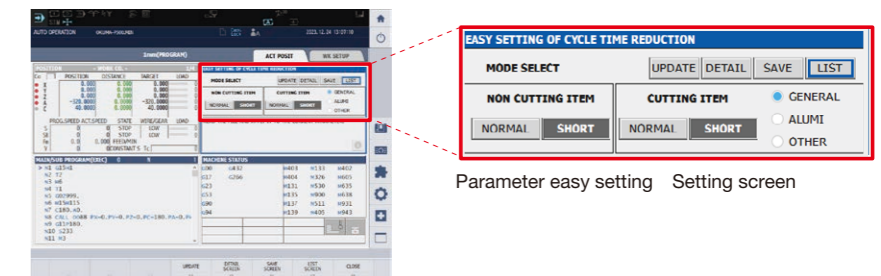

### Tool change time is shortened by reducing residual coolant discharge time

#### Suction of excess coolant in spindle

Residual coolant in tools is removed instantly in 0.9 seconds (actual value for drill tools). The suction of coolant in spindles eliminates the need for air blowing to remove residual coolant (at least 15 seconds), and so shortens tool change time.

**Coolant suction time 0.9 sec\***

\* The coolant suction time varies depending on the tool.  
Note: It can be selected in the thru-spindle coolant specification.

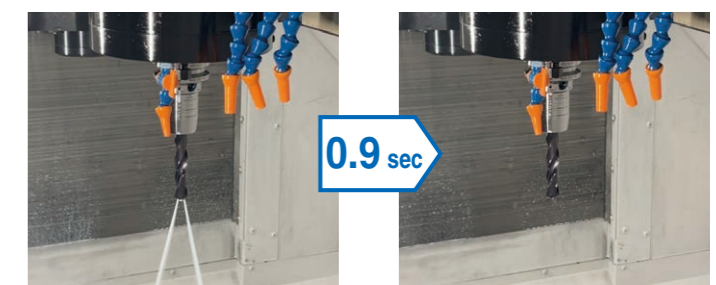

Ease of use with consideration of harmony between people and machines

# MB-80V



## ① OSP-P500 operation panel with excellent operability and visibility

Operation panel for visibility and operability by swivel movement

- Workpiece and operation screen X-Y-Z directions are the same
- The panel swivels for an easy visual check of the inside of the machine
- The angle can be adjusted to suit the body height of the operator



It can be swiveled according to the working position, ensuring good operability

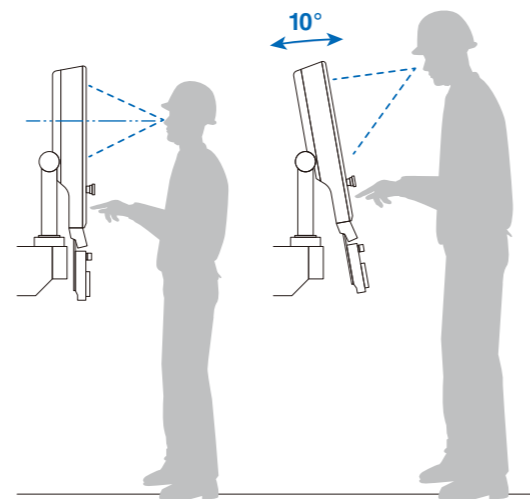

Body height **158 cm** (62.20 in)      Body height **185 cm** (72.83 in)  
The angle can be adjusted to suit the body height of the operator

## ② Wide opening width for easy setup of large workpieces

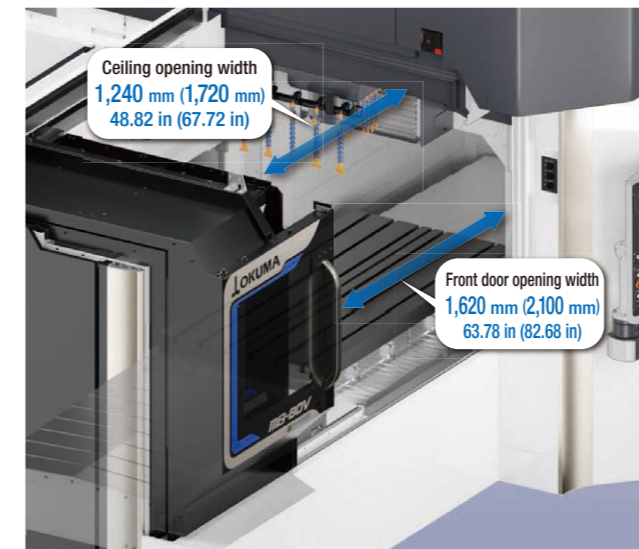

( ) is for X-axis travel of 2,000 mm

## ③ Large window for excellent visibility, making it easy to see the machining status



## ④ Good accessibility to the table and spindle

Easy operation with the table positioned at an appropriate height and comfortable accessibility to the machine

- From the machine front cover to the spindle center: **220 mm** (8.66 in)
- From the machine front cover to the table: **345 mm** (13.58 in)



## Consolidating maintenance areas to complete daily inspections smoothly

The maintenance area is consolidated on the right side of the machine.



Ease of use with consideration of harmony between people and machines

# MB-100V

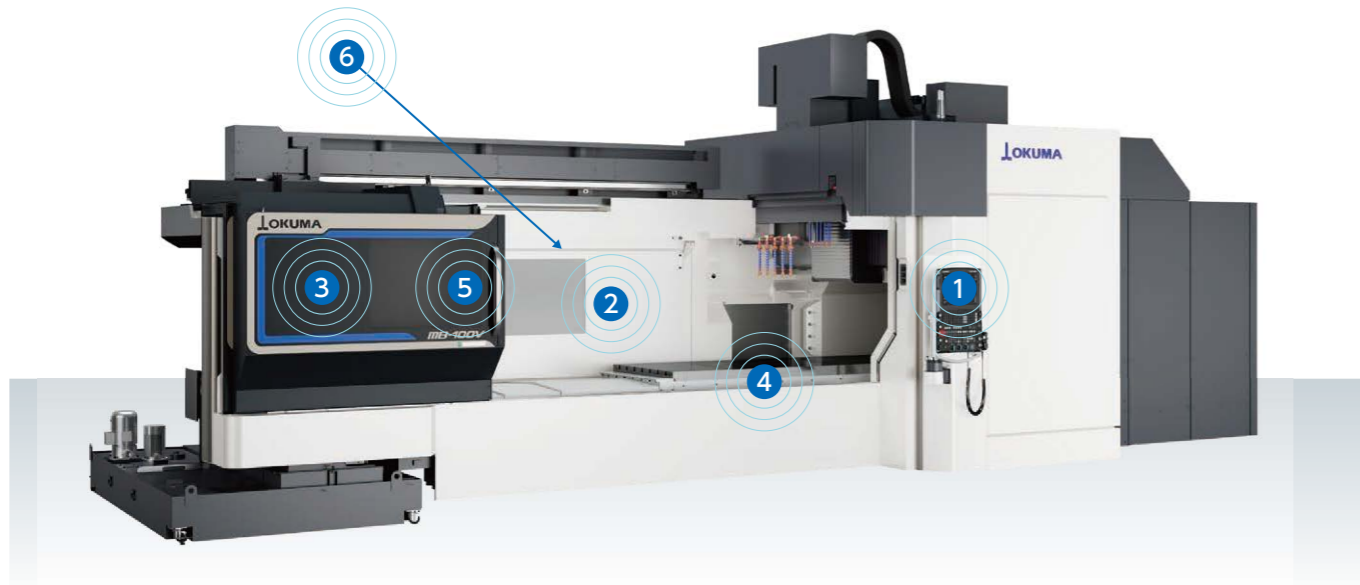

## 1 OSP-P500 operation panel with excellent operability and visibility

The panel swivels for the adjustment of the position according to the height of the operator for comfortable operation. (For details, please refer to P17)

## 2 Wide opening width for easy setup of large workpieces

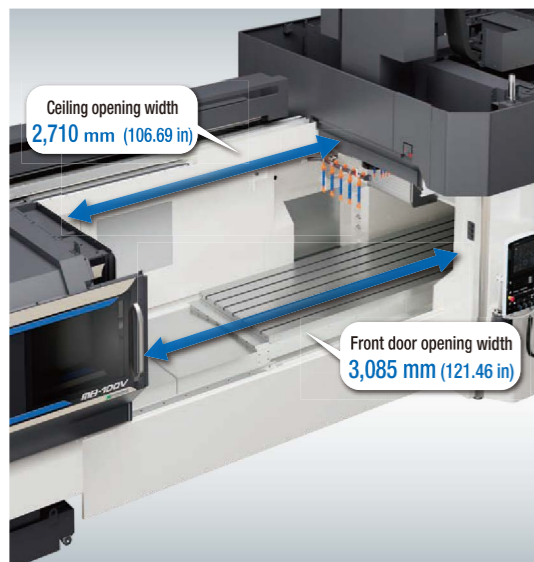

## 3 Large window for excellent visibility, it easy to see the machining status

## 4 Good accessibility to the table and spindle

Easy operation with the table positioned at an appropriate height and comfortable accessibility to the machine

- From the front of the machine to the spindle: 170 mm (6.69 in)
- From the front of the machine to the table: 305 mm (12.01 in)



## 5 The automatic door (electric) is adopted as standard, making it easy to open and close

In addition to full opening and closing, the door can be opened and closed at any position by inching

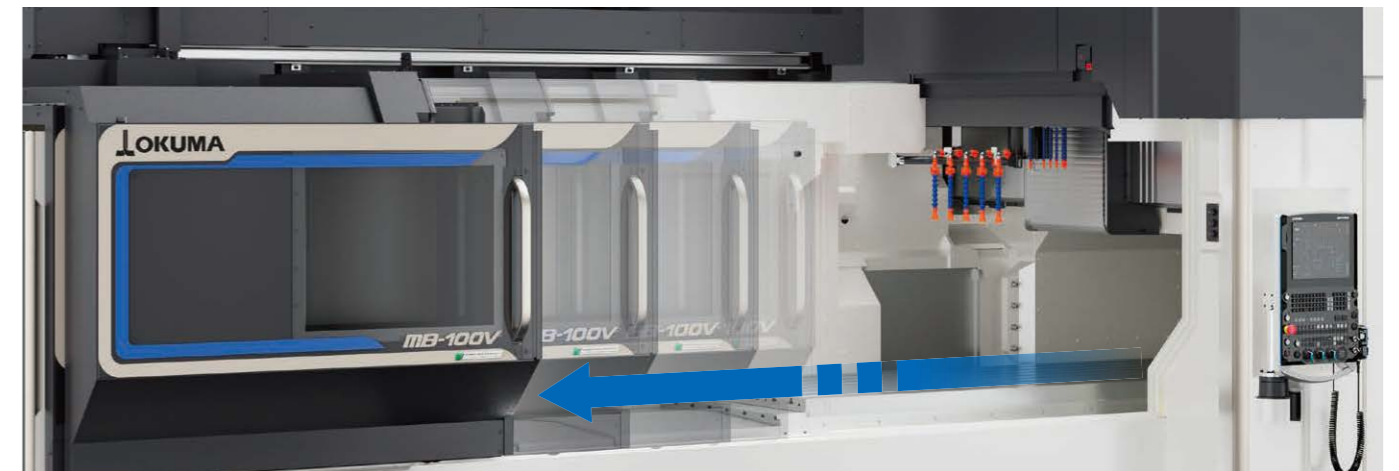

## 6 An operation door and sub-operation panel are adopted as standard on the rear side of the machine, eliminating the need to work in an awkward position and improving safety and work efficiency

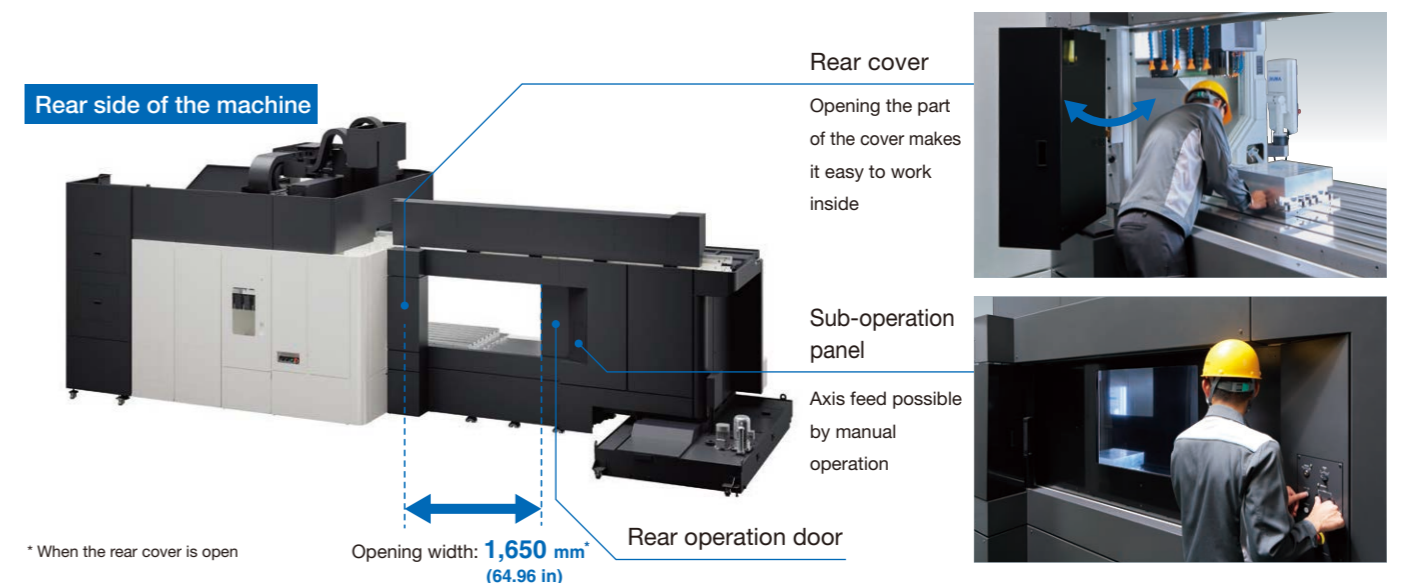

## Consolidating maintenance areas to complete daily inspections smoothly

The maintenance area is consolidated on the right side of the machine. Machine layout that takes daily inspections into consideration

A next-generation CNC that makes customer manufacturing

# OSP-P500

## Improved productivity and stable production

As Your Single Source for M-E-I-K (Mechanics - Electronics - IT - Knowledge) merging technologies, Okuma offers this CNC to build an advanced “digital twin” that faithfully reproduces machine control and machining operations and creates new value. In addition, the product helps improve productivity and realize stable production, featuring ease of use that allows customers to use their machining know-how. Additional features are: control technology that achieves high-speed and high-accuracy machining, energy-saving solutions that achieve both high accuracy/productivity and eco-friendliness, and robust security functions to protect against the increasing threat of cyber attacks.

15-inch operation panel



DX (digital transformation) a reality

- 1 Faithful digital reproduction of machines and processes
  - | Ground-breaking concept of a digital twin
- 2 Novice-friendly smart operation
  - | Innovative operability
- 3 Realizing high-speed and high-accuracy machining
  - | Revolutionary control technology
- 4 Increasing cyber resilience
  - | Robust security



Home screen



Virtual machining

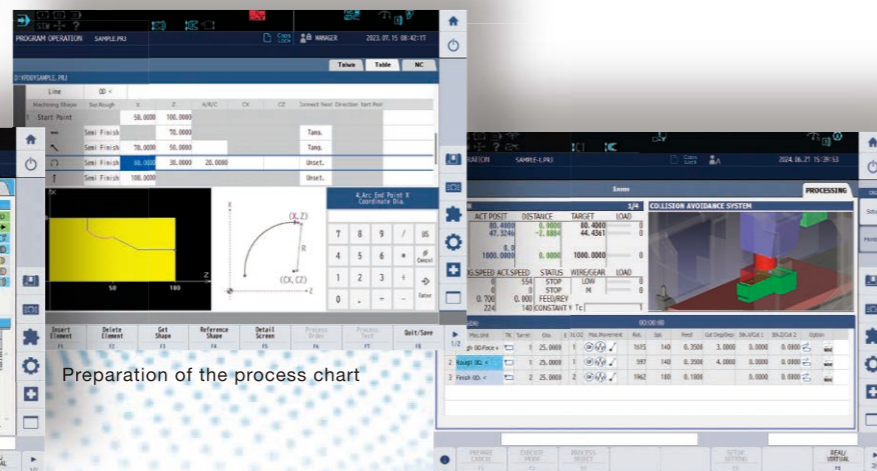

Preparation of the process chart

Operation with the process chart

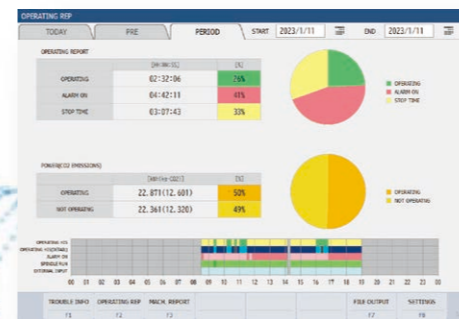

MacMan plus

**OSP-P500** A next-generation CNC that makes customer manufacturing DX (digital

**1 Faithful digital reproduction of machines and processes**

Digital Twin option

**Ground-breaking concept of a digital twin**

The digital twin calculates cycle time, machining shape, and electricity consumption through super high-speed and high-accuracy simulation. It supports accurate estimates of cycle time, development of the machining schedule, and quick and accurate estimates of delivery time and costs when an order is received.

Simulation using the latest machine information can be achieved even with an office PC or with the built-in OSP-P500.

This enables preparation for machining in advance in the office environment (front loading).

Physical machine preparation time can be reduced by using digital twin preparation results to prepare for machining the next parts while machining continues.

When a problem occurs on the shop floor, it can be solved quickly on site without going back to the office.



**2 Novice-friendly smart operation**

Smart OSP Operation option

**Innovative operability**

Conventionally, machining operations are programmed with G-/M-code based on drawings. With OSP-P500, however, you only have to follow the guidance to enter drawing information. So you can prepare for machining quickly, even if you have no familiarity at all with the NC program language.

**High-productivity programs are easy to create**

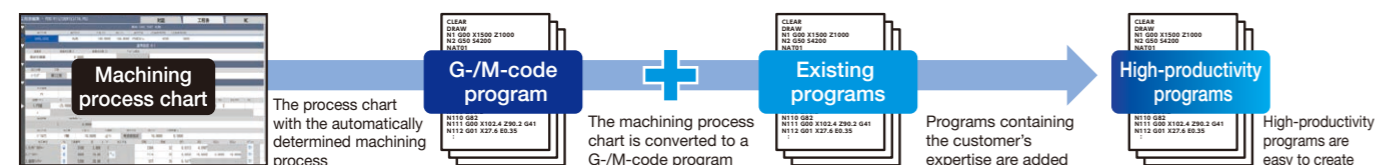

transformation) a reality

**3 Realizing high-speed and high-accuracy machining**

**Revolutionary control technology**

CNC operation performance has been doubled compared to the conventional model (OSP-P300A).

The processing capacity and the response speed between control modules have been improved to shorten the machining time.

The time for machining general parts can be shortened if the machining program and machining conditions are the same as before.

**4 Protecting the operation of machines and precious assets such as part programs from cyber attacks**

**Robust security that increases cyber resilience**

As digital networks develop and servers are increasingly connected to factory machines, the threat of cyber attacks increases, making it ever more important to protect against them.

OSP-P500 is equipped with robust security functions for defense against and protection from cyber attacks, along with data restoration, to protect the operation of machines and precious assets such as part programs in the event of a cyber attack.

<b>Defense</b>	Prevent unauthorized access and connection	Identification of operators and communications, authentication function, etc.
<b>Protection</b>	Control damage	Anti-virus measures based on the allowlist, functions to prevent falsification and detect abnormalities, etc.
<b>Data restoration</b>	Preparation for emergencies	Control software and data backup function, etc.

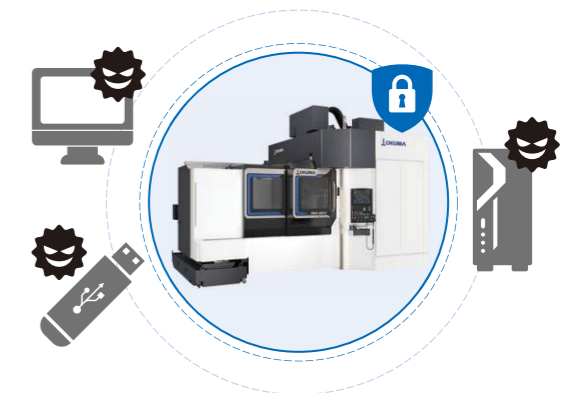

**OSP-VPSII (Virus Protection System II)**

OSP-VPSII (Virus Protection System II) incorporates allowlisting\*1 antivirus functions into the Okuma CNC (OSP) to prevent infection by viruses via networks and USB devices.

**OSP-VPSII-STD**

OSP-VPSII-STD [Standard] includes antivirus functions developed exclusively for Okuma's numerically controlled machines. Machines can be used safely, as only software tested by Okuma can be run.

Note: Because the allowlist is locked, only Okuma software can be run.

**OSP-VPSII-EX (option)**

OSP-VPSII-EX [Expert] includes antivirus functions made by TXOne Networks\*2.

The allowlist can be edited by the customer, so any software can be installed\*3.

Note: Incorrectly editing the allowlist may prevent OSP from operating normally, so specialized knowledge of allowlisting antivirus functions is required.

\*1. Allowlisting is a method in which safe software is listed and software not included in the list is prevented from running.

\*2. TXOne Networks is a registered trademark of TXOne Networks Inc.

\*3. This does not guarantee the operation of any software on OSP. Note that installed software may prevent OSP from operating properly.

# Energy-saving technology

It contributes to providing both high productivity and high precision while being eco-friendly

Achieving high accuracy and high productivity while achieving decarbonization and energy saving



Okuma has worked to reduce energy consumption in order to achieve carbon neutrality at the three factories in Japan which are our main production bases. We have realized high productivity through automation and process-intensive machining, in addition to high-accuracy machining, and we then introduced the use of green energy to transform the three domestic factories into carbon-neutral factories. "Green-Smart Machines" is our definition of Okuma's intelligent machine tools, which autonomously achieve stable dimensional accuracy and reduced energy consumption, to support environmentally friendly production. Our policy is to deploy "Green-Smart Machines" fully, to help achieve a carbon-free society. Starting with products manufactured at those carbon-neutral factories and supplying them all over the world, we will work together with our customers to help solve the social issues faced by the manufacturing industry.

Green-Smart Machines are **environmentally friendly** products that autonomously achieve stable dimensional accuracies and reduced energy consumption.

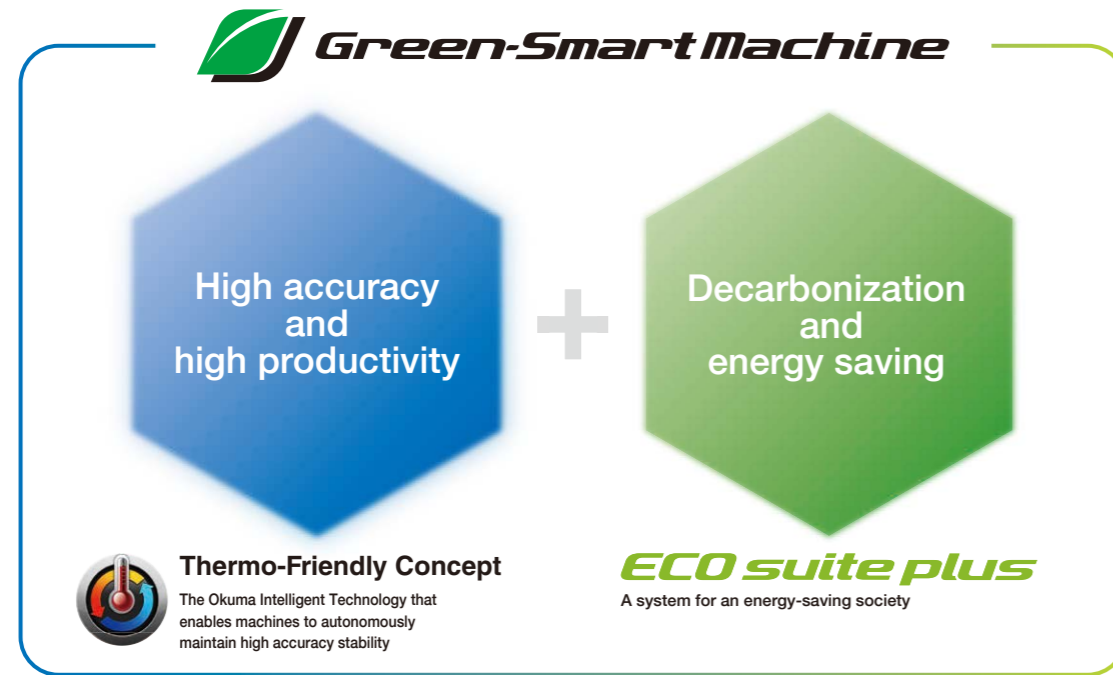

The Okuma Intelligent Technology that enables machines to autonomously maintain high accuracy stability



The unique concept of accepting temperature changes achieves consistent high accuracy without special coolers or excessive air conditioning.

- Reduction of warm-ups and dimensional compensation**  
Reduce the time needed for daily warm-ups and dimensional compensation to adjust to ambient temperature changes.
- Reduction of power used for air conditioning**  
Maintain high stability of dimensional accuracy even if the air conditioning temperature range is expanded.
- Reduction of machine body coolers**  
Achieve outstanding dimensional accuracy without any special machine body cooling being required to maintain accuracy.

### The Okuma way to cool

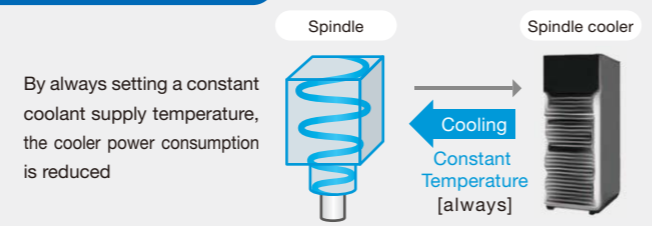

A system for an energy-saving society

## ECO suite plus

The "ECO suite plus" retains the concept of achieving both high machining accuracy stability and energy savings (less carbon dioxide emissions) achieved by the Thermo-Friendly Concept and the "ECO suite" that was put into practical use in 2014. It is an energy-saving system with enhanced high-accuracy/productive functionality and advanced eco-friendly support.

### Ensure accuracy and actively turn off unnecessary peripherals

#### ECO Idling Stop

All auxiliary equipment when not needed (most of factory power consumption), can be turned off. The ECO Idling Stop button enables diligent idle stop operations even during machining and maintenance work. The cooling system necessary for maintaining accuracy uses Thermo-Friendly Concept technology, and the machine itself decides when to cool and stop idling while maintaining high accuracy. With ECO suite plus, the machine automatically detects the operating status, eliminating the need to push buttons while reducing carbon dioxide emission as much as possible without operator awareness.

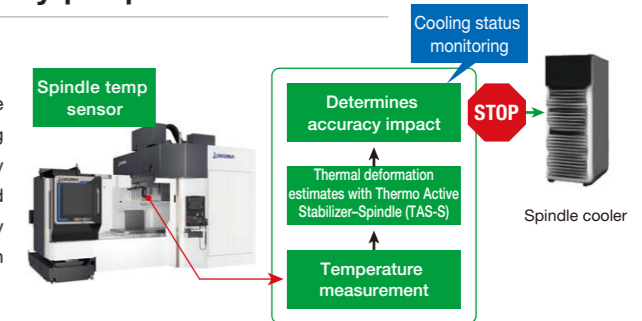

### Peripheral equipment runs only when needed

#### ECO Operation

By using only the required peripherals (chip conveyors, mist collectors, etc.), energy-saving operations that also maintain high productivity are possible. ECO suite plus enables more detailed tuning of operations to thoroughly support carbon dioxide emission reduction activities that do not reduce productivity.

ECO PARAMETER	ECO IDLE STOP	ECO OPERATION
ECO IDLE STOP ELAPSED TIME	0000000	REMAINING TIME UNTIL ECO IDLE STOP READY 12:46
Chip conveyor interval control	OFF	UNIT
Chip conveyor interval/active time	100	[min]
Chip conveyor interval/suspended time	200	[min]

### Confirming energy savings and analyzing reductions

#### ECO Power Monitor

Making it possible for the OSP control to analyze the operating status of each device. The decarbonization cycle on the shop floor is supported through the three phases, 1. View, 2. Record, and 3. Analyze.

- Check carbon dioxide emissions on the spot**

With ECO suite plus, you can also check the power consumption of each device.

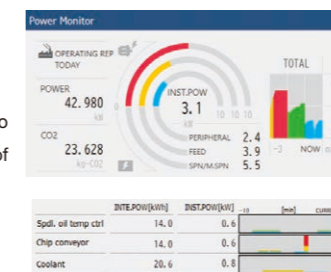

- Simultaneously records operating status and carbon dioxide emissions**

With ECO suite plus, recording carbon dioxide emissions for each device, and data output is possible.

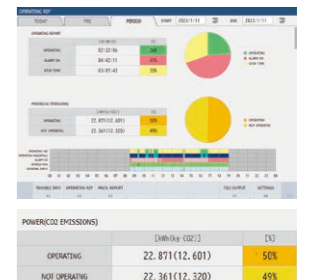

- Analyze carbon dioxide emissions and improve machine tool operation**

With ECO suite plus, not only the display on the machine but data analysis for each device is also possible on a PC, to see a more detailed carbon dioxide emission analysis.

Example of utilizing One-Touch Spreadsheet (option) to create visual feedback of machine's power consumption and carbon dioxide emissions.

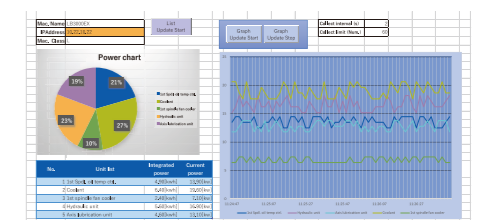

## Machine Specifications

		MB-80V	
		No. 40 spindle	No.50 spindle
Travels	X-axis (table L/R)	mm (in)	1,600 [2,000] <sup>*1</sup> (62.99 [78.74] <sup>*1</sup> )
	Y-axis (ram saddle B/F)	mm (in)	1,050 (41.34)
	Z-axis (spindle U/D)	mm (in)	600 [750] <sup>*2</sup> (23.62 [29.35] <sup>*2</sup> )
	Table top [Pallet top] <sup>*3</sup> to spindle nose	mm (in)	200 to 800 [150 to 750] <sup>*3</sup> [200 to 950] <sup>*2</sup> [150 to 900] <sup>*2*3</sup> (7.87 to 31.50 [5.91 to 29.53] <sup>*3</sup> [7.87 to 37.40] <sup>*2</sup> [5.91 to 35.43] <sup>*2*3</sup> )
Table	Table size [pallet top] <sup>*3</sup>	mm (in)	1,600 × 800 [2,000 × 800] <sup>*1</sup> (62.99 × 31.50 [78.74 × 31.50] <sup>*1</sup> )
	Floor to table top [pallet top] <sup>*3</sup>	mm (in)	900 [1,150] <sup>*3</sup> (35.43 [45.28] <sup>*3</sup> )
	Max load capacity <sup>*4</sup>	kg (lb)	2,500 [4,000] <sup>*5</sup> [1,500] <sup>*3</sup> [2,000] <sup>*3*5</sup> (5,500 [8,800] <sup>*5</sup> [3,300] <sup>*3</sup> [4,400] <sup>*3*5</sup> )
Spindle	Speed	min <sup>-1</sup>	15,000 [12,000] <sup>*6</sup> [20,000] <sup>*7</sup>   12,000
	Speed range		Infinitely variable
	Tapered bore		7/24 taper No. 40 [HSK-A63] <sup>*8</sup>   7/24 taper No. 50 [HSK-A100] <sup>*8</sup>
	Bearing dia	mm (in)	ø70 [ø90] <sup>*6</sup> (ø2.76 [ø3.54] <sup>*6</sup> )   ø90 (ø3.54)
Feed rate	Rapid traverse <sup>*4</sup>	m/mim (ipm)	X: 42 [30] <sup>*1*3</sup> [20] <sup>*5</sup> , Y: 42 [42] <sup>*1*3</sup> [20] <sup>*5</sup> , Z: 32 [32] <sup>*1*3</sup> [20] <sup>*5</sup> (X: 1,654 [1,181] <sup>*1*3</sup> [787] <sup>*5</sup> , Y: 1,654 [1,654] <sup>*1*3</sup> [787] <sup>*5</sup> , Z: 1,260 [1,260] <sup>*1*3</sup> [787] <sup>*5</sup> )
	Cutting feed rate <sup>*4</sup>	mm/min (ipm)	X: 32,000 [30,000] <sup>*1*3</sup> [20,000] <sup>*5</sup> , Y: 32,000 [32,000] <sup>*1*3</sup> [20,000] <sup>*5</sup> , Z: 32,000 [32,000] <sup>*1*3</sup> [20,000] <sup>*5</sup> (X: 1,260 [1,181] <sup>*1*3</sup> [787] <sup>*5</sup> , Y: 1,260 [1,181] <sup>*1*3</sup> [787] <sup>*5</sup> , Z: 1,260 [1,260] <sup>*1*3</sup> [787] <sup>*5</sup> )
Motors	Spindle	kW (hp)	26/18.5 [33/26] <sup>*6</sup> [30/22] <sup>*7</sup> (35/25 [44/35] <sup>*6</sup> [40/30] <sup>*7</sup> )   33/26 (44/35)
	Feed axes	kW (hp)	X: 5.2, Y, Z: 3.5 (X: 6.9 Y, Z: 4.7)
Auto tool changer (ATC)	Tool shank		MAS403 BT40 [HSK-A63] <sup>*8</sup>   MAS403 BT50 [HSK-A100] <sup>*8</sup>
	Pull stud		MAS2, [-] <sup>*8</sup>
	Magazine capacity	tools	32 (chain magazine) [48, 64 (chain magazine), over 64 (matrix magazine)] <sup>*9</sup>
	Max tool dia (w/adjacent tool)	mm (in)	ø90 (ø3.54)   ø100 (ø3.94)
	Max tool dia (w/o adjacent)	mm (in)	ø125 (ø4.92)   ø152 (ø5.98)
	Max tool length	mm (in)	400 (15.75)
	Max tool mass	kg (lb)	8 (17.6)   12 [15] <sup>*10</sup> (26.4 [33] <sup>*10</sup> )
	Max tool moment	N-m (ft-lbf)	7.8 (5.7)   15.3 [19.1] <sup>*10</sup> (11.3 [14] <sup>*10</sup> )
	Tool selection		Memory random (Matrix magazine types use the fixed address)
Machine size	Height	mm (in)	3,320 [3,520] <sup>*3</sup> [3,500] <sup>*2</sup> [3,700] <sup>*2*3</sup> (130.71 [138.58] <sup>*3</sup> [137.80] <sup>*2</sup> [145.67] <sup>*2*3</sup> )
	Floor space (machine only)	mm (in)	4,500 × 2,970 [5,900 × 2,970] <sup>*1</sup> [6,955 × 3,780] <sup>*3</sup> [8,705 × 3,780] <sup>*1*3</sup> (177.17 × 116.93 [232.28 × 116.93] <sup>*1</sup> [273.82 × 148.82] <sup>*3</sup> [342.72 × 148.82] <sup>*1*3</sup> )
	Mass (ATC 32 tools, machine only)	kg (lb)	16,750 [18,250] <sup>*1</sup> [18,600] <sup>*3</sup> [20,450] <sup>*1*3</sup>   17,000 [18,500] <sup>*1</sup> [18,500] <sup>*3</sup> [20,700] <sup>*1*3</sup> (36,850 [40,150] <sup>*1</sup> [40,920] <sup>*3</sup> [44,990] <sup>*1*3</sup> )   (37,400 [40,700] <sup>*1</sup> [40,700] <sup>*3</sup> [45,540] <sup>*1*3</sup> )
Controller		OSP-P500M	

[ ]: option

\*1. X-axis travel: 2,000 mm

\*2. Z-axis travel: 750 mm

\*3. APC spec

\*4. For die/mold specifications, the rapid traverse and cutting feed rate are limited to 20 m/min.

\*5. Die/mold kit

\*6. High-power spindle

\*7. High-speed spindle

\*8. Dual contact spindle (HSK)

\*9. Increased ATC magazine capacity

\*10. 15 kg tool mass support spec

## Standard Specifications & Accessories

		MB-80V
No.40 spindle speed 15,000 min <sup>-1</sup> *1		26/18.5 kW (10 min/cont)
Rapid traverse		X-Y: 42, Z: 32 m/min
Spindle/spindlehead cooler		Oil temperature controller
Ball screw cooling		X-Y-Z axes
TAS-S (Thermo Active Stabilizer—Spindle)		
TAS-C (Thermo Active Stabilizer—Construction)		
Air cleaner (filter)		Regulator included
Spindle oil-air lubricator		
Centralized lubricant automatic oil supplier		Ball-screw, guide, magazine
ATC magazine capacity		32 tools
ATC magazine shutter		Air-driven type
Tool unclamp package		
Table		Millimeter specs
		Table groove 18H7 × 6, crossrail groove
Coolant system		Tank 550 L (effective 360 L)
		Pump motor 3.3/3.8 kW (50/60 Hz)
Coolant nozzles		Adjustable coolant system (6 pcs)
Full enclosure shielding		With ceiling
In-machine chip discharge		Hinge-type chip conveyor
Chip pan <sup>*2</sup>		91 L
ATC air blower (blast)		
Chip air blower (blast)		Nozzles
Spindle air blower		
Foundation washers (with jack bolts)		14 pcs
3-lamp status indicator		Type C (LED signal tower) Red (alarm), Yellow (end), Green (running)
Work lamp		LED lamps (installed on right and left sides)
Tapered bore cleaning bar		
Y-axis bellows cover		
Hand tools		
Tool box		
Controller		OSP-P500M
Color LCD operation panel		15 inch
Pulse handle		
Automatic door		Air-driven type (option)
Door interlock		

\*1. The spindle tapered bore is compatible with 7/24 taper No. 40 (BT40, BIG-PLUS®, CAT40, DIN40), and HSK-A63.

\*2. "Required" optional specs.

## Machine Specifications

		MB-100V	
		No. 40 spindle	No. 50 spindle
Travels	X-axis (table L/R)	mm (in)	3,200 (125.98)
	Y-axis (ram saddle B/F)	mm (in)	1,250 (49.21)
	Z-axis (spindle U/D)	mm (in)	750 (29.53)
	Table top [Pallet top] to spindle nose	mm (in)	200 to 950 (7.87 to 37.40)
Table	Table size [pallet top]	mm (in)	3,000 × 1,000 (118.11 × 39.37)
	Floor to table top [pallet top]	mm (in)	900 (35.43)
	Max load capacity	kg (lb)	6,000 (13,200)
Spindle	Speed	min <sup>-1</sup>	15,000 [12,000] <sup>*3</sup> [20,000] <sup>*4</sup>
	Speed range		Infinitely variable
	Tapered bore		7/24 taper No. 40 [HSK-A63] <sup>*5</sup>   7/24 taper No. 50 [HSK-A100] <sup>*5</sup>
	Bearing dia	mm (in)	ø70 [ø90] (ø2.76 [ø3.54])   ø90 (ø3.54)
Feed rate	Rapid traverse <sup>*1</sup>	m/min (ipm)	X, Z: 32, Y: 42 [X, Y, Z: 20] <sup>*2</sup> (X, Z: 1,260, Y: 1,654 [X, Y, Z: 787] <sup>*2</sup> )
	Cutting feed rate <sup>*1</sup>	mm/min (ipm)	X, Y, Z: 32,000 [X, Y, Z: 20,000] <sup>*2</sup> (X, Y, Z: 1,260 [X, Y, Z: 787] <sup>*2</sup> )
Motors	Spindle	kW (hp)	26/18.5 [33/26] <sup>*3</sup> [30/22] <sup>*4</sup> (35/25 [44/35] <sup>*3</sup> [40/30] <sup>*4</sup> )   33/26 (44/35)
	Feed axes	kW (hp)	X: 6.4, Y, Z: 3.5 (X: 8.5, Y, Z: 4.7)
Auto tool changer (ATC)	Tool shank		MAS403 BT40 [HSK-A63] <sup>*5</sup>   MAS403 BT50 [HSK-A100] <sup>*5</sup>
	Pull stud		MAS2, [-] <sup>*5</sup>
	Magazine capacity	tools	32 (chain magazine) [48, 64 (chain magazine), over 64 (matrix magazine)] <sup>*6</sup>
	Max tool dia (w/adjacent tool)	mm (in)	ø90 (ø3.54)   ø100 (ø3.94)
	Max tool dia (w/o adjacent)	mm (in)	ø125 (ø4.92)   ø200 (ø7.87)
	Max tool length	mm (in)	400 (15.75)
	Max tool mass	kg (lb)	8 (17.6)   12 (26.4)
	Max tool moment	N-m (ft-lbf)	7.8 (5.7)   15.3 (11.3)
	Tool selection		Memory random
Machine size	Height	mm (in)	3,500 (137.80)
	Floor space (machine only)	mm (in)	8,995 × 3,095 (354.13 × 121.85)
	Mass (ATC 32 tools, machine only)	kg (lb)	25,000 (55,000)
Controller		OSP-P500M	

[ ]: option

\*1. For die/mold specifications, the rapid traverse and cutting feed rate are limited to 20 m/min.

\*2. Die/mold kit

\*3. High-power spindle

\*4. High-speed spindle

\*5. Dual contact spindle (HSK)

\*6. Increased ATC magazine capacity

## Standard Specifications & Accessories

		MB-100V
No.50 spindle speed 12,000 min <sup>-1</sup> *1		33/26 kW (10 min/cont)
Rapid traverse		X-Z: 32m/min, Y: 42m/min
Spindle/spindlehead cooler		Oil temperature controller
Ball screw cooling		X-Y-Z axes
TAS-S (Thermo Active Stabilizer—Spindle)		
TAS-C (Thermo Active Stabilizer—Construction)		
Air cleaner (filter)		Regulator included
Spindle oil-air lubricator		
Centralized lubricant automatic oil supplier		Ball-screw, guide, magazine
ATC magazine capacity		32 tools
ATC magazine shutter		Electric type
Tool unclamp package		
Table		Millimeter specs
		Table groove 18H7 × 7
Coolant system		Tank 1,020 L (effective 660 L)
		Pump motor 0.55/0.75 kW (50/60 Hz)
Coolant nozzles		Adjustable coolant system (6 pcs)
Full enclosure shielding		With ceiling
In-machine chip discharge		Hinge-type chip conveyor
Chip pan <sup>*2</sup>		97 L
ATC air blower (blast)		
Chip air blower (blast)		Nozzles
Spindle air blower		
Foundation washers (with jack bolts)		26 pcs
3-lamp status indicator		Type C (LED signal tower)
		Red (alarm), Yellow (end), Green (running)
Work lamp		LED lamps (installed on right and left sides)
Tapered bore cleaning bar		
Y-axis bellows cover		
Hand tools		
Tool box		
Controller		OSP-P500M
Color LCD operation panel		15 inch
Pulse handle		
Automatic door		Electric type
Rear operation door (sub-control panel)		
Door interlock		

\*1. The spindle tapered bore is compatible with 7/24 taper No. 50 (BT50, BIG-PLUS®, CAT50, DIN50), and HSK-A100.

\*2. "Required" optional specs.

## Optional Specifications & Accessories

	MB-80V	MB-100V
No.40 high-speed spindle 20,000 min <sup>-1</sup> *1 △	30/22 kW (10 min/cont)	
No.40 high-power spindle 12,000 min <sup>-1</sup> *1 △	33/26 kW (10 min/cont)	
No.50 high-power spindle 12,000 min <sup>-1</sup> *2 △	33/26 kW (10 min/cont)	
Dual contact spindle*3 △	HSK*4, BIG-PLUS®	
ATC magazine capacity △	Chain magazine: 48, 64 tools Matrix magazine: 64, 98, 132, 166, 200, 243, 268 tools	
Pull stud △	MAS1, CAT, DIN, JIS	
Attachment preparations	Accelerator attachment, Angle-head attachment, Oil-hole supplier	
X-axis travel 2,000 mm △	Foundation washers (with jack bolts): 18 pcs	—
Die/mold kits	X-Y-Z axes rapids: 20 m/min X-Y-Z axes cutting feeds: 20 m/min Table load capacity: 4,000 kg Large foundation washer Hyper-Surface, 0.1 μm control AbsoScale detection X-Y-Z axes	X-Y-Z axes rapids: 20 m/min X-Y-Z axes cutting feeds: 20 m/min Table load capacity: 8,000 kg Large foundation washer Hyper-Surface, 0.1 μm control AbsoScale detection X-Y-Z axes
AbsoScale detection	X-Y-Z axes	
Auto pallet changer (APC)	Two-sided APC (mounted on the left side)	
Automation	Loader, robot, FMS	
Automatic door	Air-driven	Electric type (standard)
NC rotary table	Specify chuck, tailstock requirements, rotary table type	
Preparations for the above		
High-crossrail specs (+200 mm) △	Required for APC specs	
Thru-spindle coolant*5	Select from 1.5 MPa or 7 MPa	
Suction of excess coolant in spindle	Can be selected for thru-spindle coolant specs.	
Chip air blower (adapter)		
Oil mist unit		
Mist collector		
Semi-dry machining		
Shower coolant systems	Under-crossrail installation, ceiling installation	
Workpiece wash gun		
Sludgeless Tank		
Off-machine chip discharge (lift-up chip conveyor) △	Hinge-type, scraper type, Hinge + scraper type	
Chip buckets for above △		
Auto tool length compensation / tool breakage detection	Touch sensor*6	
Auto zero offset/Auto gauging	Touch probe	
Collision Avoidance System		
Machining Navi M-i, M-gII+	Cutting condition search	
NC Gage	Standard kit, high spec kit	
3D Smart Calibration System	Includes linear axis error measurement and spatial error compensation	
Chemical anchors		
Y-axis armored bellows specs	Recommended when the main material being machined is aluminum (excluding the MB-80V die/mold kit specs)	

△: Corresponding standard specification is deleted.

\*1. The spindle tapered bore is compatible with 7/24 taper No. 40 (BT40, BIG-PLUS®, CAT40, DIN40), and HSK-A63.

\*2. The spindle tapered bore is compatible with 7/24 taper No. 50 (BT50, BIG-PLUS®, CAT50, DIN50), and HSK-A100.

\*3. Be sure to select this specification when BIG-PLUS® holder is used.





\*4. Use an HSK holder equipped with a coolant supply pipe.

\*5. Requires Okuma's-dedicated pull-stud bolt (different end grinding, O-ring, and through-hole diameter than commercially available products).

\*6. Table mounted; which may limit available working range.

## Recommended Chip Conveyors (Please contact an Okuma sales representative for details.)

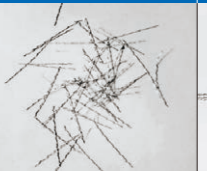
○ : Recommended △ : Conditionally recommended

Workpiece Material	Steel	Cast iron	Aluminum / non-ferrous metal	Mixed (general use)
Chip shape				
In-machine chip discharge	Hinge type (standard)	○	○	○
Off-machine chip discharge (option)	Hinge + scraper with drum filter	○	○	○
	Hinge type	○	—	△*1
	Scraper type	—	○ (dry)	—
	Scraper type with drum filter	—	○ (wet) with magnet	△*2

\*1. When there are few fine chips \*2. When chips are shorter than 100 mm

## Off-machine lift-up chip conveyors

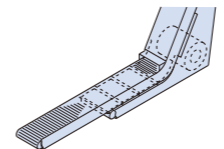
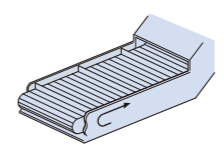
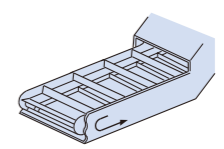
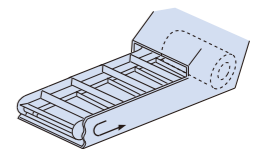
Type	Hinge + scraper with drum filter	Hinge	Scraper	Scraper with drum filter
Shape				

Note: Becomes hinge + scraper with drum filter if Sludgeless Tank (option) is selected.

Standard Specifications

Basic Specs	Control	X, Y, Z, simultaneous 3-axis, spindle control (1 axis)
	Position feedback	OSP full range absolute position feedback (zero point return not required)
	Coordinate functions	Work coordinate system (20 sets)
	Min / Max command	±99999.999 mm, ±9999.9999° 8-digit decimal, command units: 0.001 mm, 0.01 mm, 1 mm, 0.0001°, 0.001°, 0.01°, 1°
	Feed override	Cutting feed override 0 to 200%, rapid traverse override 0 to 100%
	Spindle override	Override 30 to 300%
	Tool information management	Compensation, life management, shape data, etc. are collectively managed for each tool (999 tools can be registered)
	Tool compensation	Tool length compensation / tool radius compensation 3 sets for each of the registered tools (up to 999 tools), maximum number of total sets: 999
	Operation panel	15-inch operation panel (15-inch XGA screen + multi-touch panel operations), Operation panel tilt adjustment, portable pulse handle (type A), Keyboard QWERTY layout, window operation that is optimal on machine shops
	Security	Operator authentication, lock screen, OSP-VPSII-STD
Machining programming	Program capacity	Program storage: 4 GB, operation buffer: 2 MB
	Programming	Program editing, file name index display, scheduled programs, Hole drilling fixed cycles (drill, deep bore drill, high-speed deep bore drill cycles, etc.), combined use of mm/min, keyway cycle, Coordinate calculation, area machining, coordinate change (shift, rotation and copying of the workpiece coordinate), Block skip (1 set), User Task (GOTO statement, IF statement, arithmetic operations, IF/THEN, DO/WHILE, GOTO (variables) statement, etc., functional operations, logic statements, inverse trigonometric functions, Common variables (std: 200 sets), local variables, system variables, sub-programs, G-/M-code macros (G-code: 20 sets, M-code: 20 sets), READ/WRITE/GET/PUT), basic interpolation, circular radius designate, taper angle designate, NCYL command, home position, Program operation type (A-Operation, B-Operation, S-Operation), oriented spindle stop, programming help
Operations	OSP suite	Various "suite" apps support the series of machining operations, and "suite operation" enables one-touch access to those apps
	Easy Operation	"Single-mode operation" to complete a series of operations, "Setup data" to set the zero point easily using the measuring function (option)
Operations	Operations	Manual cutting feed, sequence return, sequence number search, manual interrupt & auto return, MDI input, Pulse handle overlap, Library programs, parameter I/O, relative actual position display, PLC monitor, operation help, Alarm help, Continued operation at the time of temporary power failure
	Monitoring, Adaptive control	Real 2D display, load meter display, maintenance monitor, collection of log data for maintenance, SERVONAVI AP, SERVONAVI SF, rotary axis notch filter switch, local variables display, display of remaining machining time
MacMan plus		Aggregation and display of machining records, operating records, operating history and trouble information, Visualization of power consumption, Records, output of records and trouble info file
Automation/Unattended operation		Auto power shutoff
Communications/Networks		USB3.0 interface (2 ports), Ethernet interface, DNC-T1, Smart I/F (Connect Plan interface), browser
High-Speed/ High-Accuracy Functions		Hi-G control, Hi-Cut Pro, pitch error compensation, TAS-S (Thermo Active Stabilizer-Spindle), TAS-C (Thermo Active Stabilizer-Construction), cycle time reduction (operation time reduction, machining time reduction, easy parameter setting), in-position check, exact stop check, variable lost motion compensation
Energy-saving functions	ECO suite plus	ECO Idling Stop, ECO Operation, oil temperature controller auto control, ECO Power Monitor*1
	Power Regeneration System	Regenerative power is used when the spindle and feed axes decelerate to reduce energy waste

\*1. The displayed power is an approximate value. If you need an accurate power value, please select the option to attach a wattmeter.

Kit Specifications

		NML		OT-IGF		Digital Twin				Digital Twin OT-IGF			
		E	D	E	D	E	D	VE	VD	E	D	VE	VD
Interactive functions	Advanced One-Touch IGF-M (including real 3-D simulation)			●	●					●	●	●	●
	Interactive MAP (I-MAP)					●	●	●	●				
	Smart OSP Operation			●	●	●	●	●	●	●	●	●	●
	Machining process chart preparation and operation												
High-Speed/High-Accuracy Functions	Dynamic displacement compensation	●	●	●	●	●	●	●	●	●	●	●	●
Digital Twin On Machine	Virtual Machining					●	●	●	●	●	●	●	●
	Quick modeling					●	●	●	●	●	●	●	●
	OPC UA for Machine Tools					●	●	●	●	●	●	●	●
	OSP API KIT					●	●	●	●	●	●	●	●
Digital Twin On PC	Virtual Machining								●	●			●
	Quick modeling								●	●			●
Programming Machining Operations	Operation buffer 10 MB	●	●	●	●	●	●	●	●	●	●	●	●
	Program notes	●	●	●	●	●	●	●	●	●	●	●	●
	Coordinate system selection	●	●	●	●	●	●	●	●	●	●	●	●
	(Std: 20 sets)												
	100 sets												
	200 sets			●		●		●		●		●	
	Helical cutting (within 360°)	●	●	●	●	●	●	●	●	●	●	●	●
	Synchronized Tapping II	●	●	●	●	●	●	●	●	●	●	●	●
	Arbitrary angle chamfering	●	●	●	●	●	●	●	●	●	●	●	●
	Programmable travel limits	●	●	●	●	●	●	●	●	●	●	●	●
Coordinate change and drawing conversion	Programmable mirror image			●		●		●		●		●	
	Enlarge/reduce			●		●		●		●		●	
Sequence stop	●	●	●	●	●	●	●	●	●	●	●	●	
Sequence return			●		●		●		●		●		
Mid-block sequence return													
Auto scheduled program update	●	●	●	●	●	●	●	●	●	●	●	●	
Tool management	Tool wear compensation	●	●	●	●	●	●	●	●	●	●	●	●
	Tool wear compensation input restriction	●	●	●	●	●	●	●	●	●	●	●	●
	Tool life management (including prior notice, warning, and special prior notice/warning)	●	●	●	●	●	●	●	●	●	●	●	●
Monitoring	Real 3-D Simulation			●	●	●	●	●	●	●	●	●	●
	Simple load monitor	●	●	●	●	●	●	●	●	●	●	●	●
	NC operation monitor (counter, totaling)	●	●	●	●	●	●	●	●	●	●	●	●
Measuring	Tool breakage no-load detection			●		●		●		●		●	
	Manual measuring (not including sensors)	●	●	●	●	●	●	●	●	●	●	●	●

Notes. NML: Normal, OT-IGF: One-Touch IGF, E: Economy, D: Deluxe, VE: Virtual Economy, VD: Virtual Deluxe.  
For each specification, please refer to Optional Specifications in P35 and P36.

Optional Specifications

Operation panel	Monitor, operation panel	21.5-inch operation panel 21.5-inch Full HD touch screen	
	Pulse handle	Portable pulse handle with function buttons (Type B1) Pulse handle with touch panel Pulse handle addition (3 pieces in total)	
	Keyboard	Keyboard ABC layout	
Interactive functions	Advanced One-Touch IGF-M	Auto operation decision (drilling, milling) A variety of machining including contouring, grooving, pocket machining, milling, boring and linear chamfering Realistic 3D simulated test cuts Direct from machining order tables (no G-/M-codes) Slope machining, 5-face machining	
	Interactive MAP (I-MAP)	Part programs can be edited according to guide maps (with figure calculation function)	
	Interactive MAP (I-MAP-B)	Solid shape machining function added to I-MAP pattern cycle	
	Interactive MAP (I-MAP-C)	Functions to determine cutting conditions and automatically determine drilling cycle added to I-MAP	
	Smart OSP Operation	Machining process chart preparation and editing functions: By using the process chart to follow the guidance, rapid preparation for machining operations is possible even without knowing G-/M-code Machining process chart operating functions: Direct operation from the machining order chart (no G-/M-code). Independent operation for each process or from the middle of a process is possible	
	Digital Twin	Virtual Machining	Confirmation tasks are more efficient in a virtual space. Machining trajectories, material scraping, interference checks*1 High-speed, high-precision machining time estimation. Power consumption (carbon dioxide emissions) estimation
		Quick modeling	Easy preparation of 3D models of tools, jigs and workpieces. Supply of affluent 3D model data. Selecting 3D models of tools allows not only virtual spaces for digital twins but also automated configuration of real space control data
		OPC UA for Machine Tools	Communication specification for machine tools compatible with OPC UA communication Compatible with OPC UA version 1.00 (essential functions)
	OSP API KIT	OSP API KIT	API for Windows®-based application development
		Imperial/metric switch	Program commands and data setting operations are switchable between metric and imperial
Programming Machining Operations	Operation buffer	10 MB	
	Sub-program large capacity operation	When a sub-program is called and executed, the relevant sub-program is searched for and executed	
	Program notes	To show notes in part program screens	
	Auto scheduled program update	Updates part programs during a scheduled run	
	Block skip	Use soft ON/OFF keys on screen to skip execution of a part program Block skip 9 sets	
	Program branch	The branch of the part program can be turned ON/OFF with soft keys on the screen (number of sets: 9)	
	Work coordinate system	Number of selected sets: 100, 200, 400	
	Helical cutting	Circular interpolation + helical axis interpolation	
	3D circular interpolation	Three dimensional interpolation	
	Skip	Axis travel by G-code, movement skip by sensor input	
	Arbitrary angle chamfering	Easy chamfering at an arbitrary corner angle (C, R)	
	Synchronized Tapping II	Synchronized tapping, deep bore synchronized tapping, high-speed deep bore synchronized tapping cycle	
	Cylindrical side machining	Can easily carry out machining of cylindrical side	
	Tool max rotational speed setting	The rotation speed limit is set for each milling tool	
	F1-digit feed	Feed speed command by designating the number - external switch type/parameter type	
	Programmable travel limits	Per G22, G23	
	Axis name designation	Can change axis name by G-code	
	Slope machining	Type I/Type II	
	Fixture offset	The workpiece coordinate of the rotary/tilting axis is offset	
	Dynamic fixture offset	The workpiece coordinate is automatically offset according to the movement of the rotary axis	
	Harmonic Spindle Speed Control (HSSC)	The spindle speed is periodically changed to avoid chatter during cutting	
	Tool grooving	Hale machining (simultaneous XY + spindle)	
	Inverse time feed	Feed rate command with cutting time	
	Spindle path control	Contouring per simultaneous control of spindle C and X-Y-Z axes	
	Dynamic Tool Load Control	Control of chipping due to tool runout during the machining of difficult-to-cut materials	
	Punch tap cycle	High-speed threading cycle using tools dedicated to punch tap	
	Coordinate change and drawing conversion	Enlarges and reduces drawings, programmable mirror image	
	User Task	Common variables: 1,000 or 2,000 sets G-code macros: 100 sets (80 sets added) Input/output variables (16 points each)	
Sequence stop	Stops machining at prescribed sequence number		
Sequence return	Mid-block sequence return		
Pulse handle angle and arc feed	Angle and arc feed with simultaneous 2-axis control by pulse handle		
Tool management	Tool life management	The cumulative number of machined workpieces or cumulative cutting time is calculated, and when the preset value is reached, a spare tool is automatically assigned Life data of each tool are displayed as graphs; tool life prior notice, tool life warning, tool life special prior notice/warning	
	Tool wear compensation	Compensation for the wear amount of the tool	
	Tool wear compensation input restriction	Limitation on the amount of tool wear compensation	
	3D tool compensation	Designates offset direction at I, J, K	
	TOOL-ID (with chips)	Central management of tool data for tools with ID chips	
	TOOL-ID (without chips)	Integration of tool data with tools for management and storage	
	TOOL-IC	Tool management with Factory Manager manufactured by BIG DAISHOWA SEIKI	

External input output Communication functions Networking	DNC connection	DNC-C/Ethernet DNC-T3 DNC-B DNC-DT	Connected to host using Ethernet I/F for MacMan-net Ethernet RS-232C for OSP, connects to host RS-232C; remote buffer operations Remote operation using Ethernet: part programs are downloaded from PCs for the machining operation		
	RS-232C interface	FL-net	RS-232C interface 1CH to 4CH Connected to host and other machines using FL-net		
	Ethernet/IP	OSP-MTConnect	Connected to host and other machines using Ethernet/IP MTConnect I/F for production management systems produced by other companies		
	Measuring	Auto tool length offset/ Auto tool breakage detection	Auto gauging	Automatically performs tool length compensation and tool breakage detection Continuous tool gauging: Multiple tools are continuously gauged automatically Checks workpiece dimension, and auto zero offset; Measured data output to file	
		Manual measurement	Interactive gauging	Easy manual tool length compensation, workpiece gauging and zero setting according to guidance on the display Easy semi-automatic tool length compensation, workpiece gauging and zero setting according to guidance on the display	
		NC Gage		Workpiece dimensions and geometrical tolerance can be measured	
		Monitoring, Adaptive control	One-Touch Spreadsheet	Collision Avoidance System (Units and actions to prevent interference are limited)	Excel® files assist machining setups Interference during automatic, MDI and manual operations is prevented Easy modeling of shape data Simultaneous movement with Hyper-Surface II and Tool Center Point Control II
			Real 3-D Simulation		Real time simulation of all machining modes (auto, MDI, manual operation) Solid/cross section/transmission display of workpieces, tool path display, tool shape display With cycle time calculator
	Automation/Unattended operation functions	Simple load monitor	NC operation monitor	Monitors spindle overload (machining stops when overloaded) NC hour meters for NC start, spindle rotation, cutting, etc. and 4 NC workpiece counters	
		Status indicator	Tool breakage no-load detection	NC running lamp, alarm lamp, machining end lamp In drilling, detects the no-load cutting status of the spindle caused by tool breakage, triggers an alarm and stops operation	
Synchronized tapping torque monitoring		MOP-TOOL	During synchronized tapping, monitors for spindle overload (overload causes machining stop and evacuation) Overload monitoring and adaptive control		
AI Machine Diagnosis*2		Machine Status Logger	AI-based spindle and feed axis diagnostics Commands, operations and spindle and feed axis loads are recorded to increase, analyze and improve machining traceability		
Cutting Status Monitor		Machining Navi M-i Machining Navi M-gII+	To reduce machining failure, spindle and feed axis loads are monitored to trigger an alarm, pause operations, and/or trigger evacuation operations Based on chatter vibration during machining, the spindle speed is automatically optimized to stabilize machining Chatter vibration during machining is visualized to help automatically select the optimal spindle speed for stable machining		
Feed axis retraction		Tool retract cycle	Pull back in axial direction during power failures Execute shelter cycle according to interruption signal		
Workpiece counters on machine		Hour meters on machine	Counted with M02 and M30 or dedicated M-code The power ON time, spindle rotation time, NC running time and cutting time are counted		
Operation end buzzer		Tapping retraction	A buzzer goes off at M02/M30 and M00/M01 and also when an alarm is generated Retract the tapping tool when a power failure occurs during tapping		
Adaptive control (AC) using external signals		Tool monitoring system	Interruption program function, slide hold, feed axis override activated using external signals CARON TMAC8 I/F		
General purpose overload detection			Detect overload in external devices and display an alarm		
High-Speed/High-Accuracy functions	Warm-up	External program	Automatically turn on the power to perform warm-up at the preset time Push button, rotary switch, digital switch, BCD		
	AbsoScale detection	Connection with automated devices	X-Y-Z axes Dynamic displacement compensation during acceleration/deceleration is compensated for, to improve machining accuracy		
	Dynamic displacement compensation		0.1 μm command increments Hyper-Surface II 3 linear axes, 3 linear axes + 2 rotary axes		
Energy-saving functions Other functions	Inductosyn detection, DD encoder detection	Straightness compensation	A-axis, B-axis, C-axis Compensation for linear axis motion		
	Misalignment compensation		Compensation for misalignment of the rotary axis rotation center		
	ECO suite plus		ECO Power Monitor (on-machine wattmeter), ECO Hydraulics, Spindle Power Peak Limiter,		
	External output interface of consumed electricity	Circuit breaker	Power shutoff with the detection of earth leakage		
	External M-signals	OSP-VPSII-EX	[4 sets, 8 sets] Signals for controlling external devices such as rotary indexing tables Allowlist-based virus protection system		
Monitor display language (multi-language)		Language switchable			

\*1. If the Collision Avoidance System specs are enabled, then interference checks can be performed for structural components of the machine in addition to workpiece, tools, and fixtures.  
\*2. With AbsoScale detection specs, ball-screw wear detection is possible.  
Note: Cannot be selected for some machine specifications.

Table size

Unit: mm

MB-80V

X-axis travel: 1,600 mm

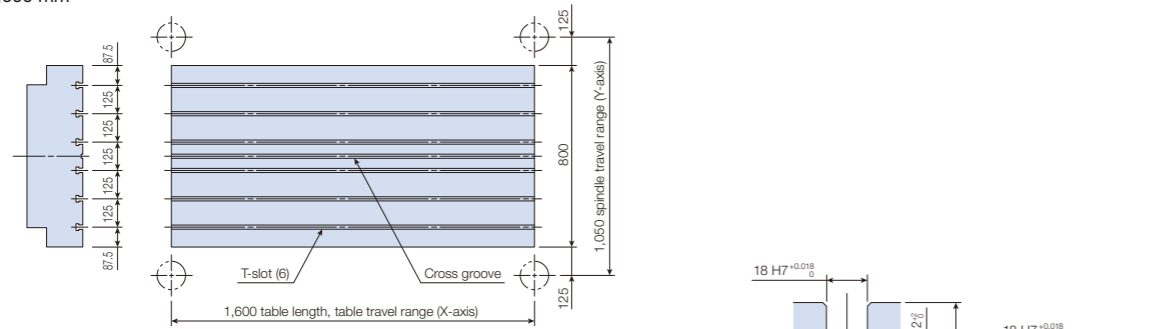

X-axis travel: 2,000 mm

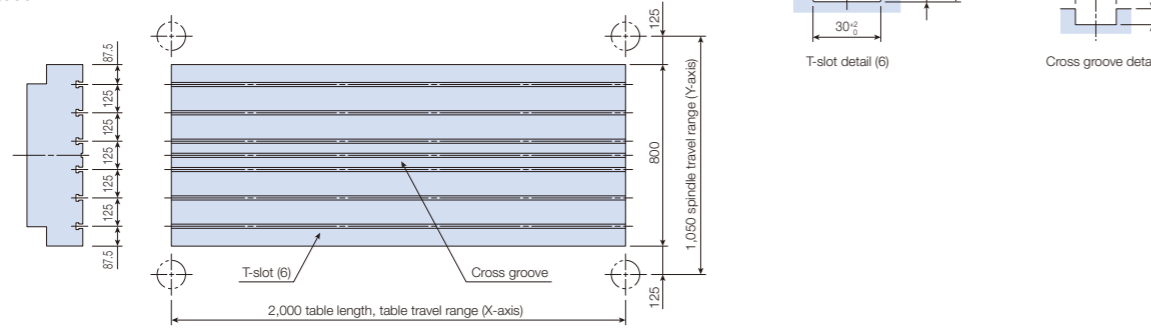

Working ranges

The dimensions in [ ] refer to those for specs with Z-axis travel of 750 mm  
 The dimensions in < > refer to those for high-crossrail specs  
 The dimensions in ( ) refer to those for APC specs  
 \* indicates the dimension from the pallet top

Unit: mm

MB-80V

X-axis travel: 1,600 mm

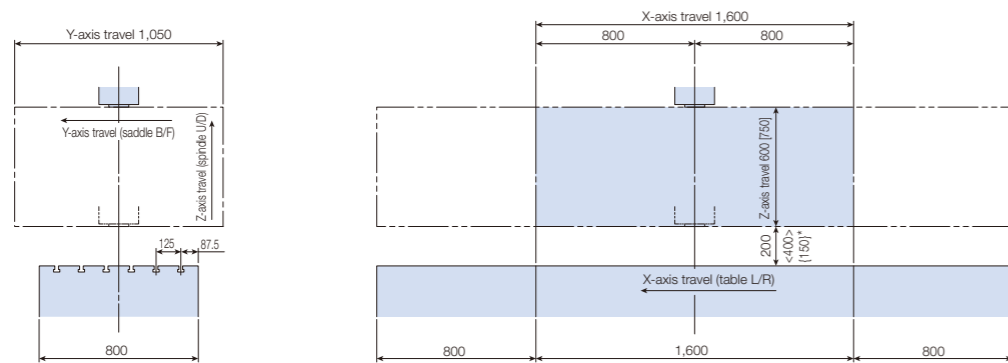

X-axis travel: 2,000 mm

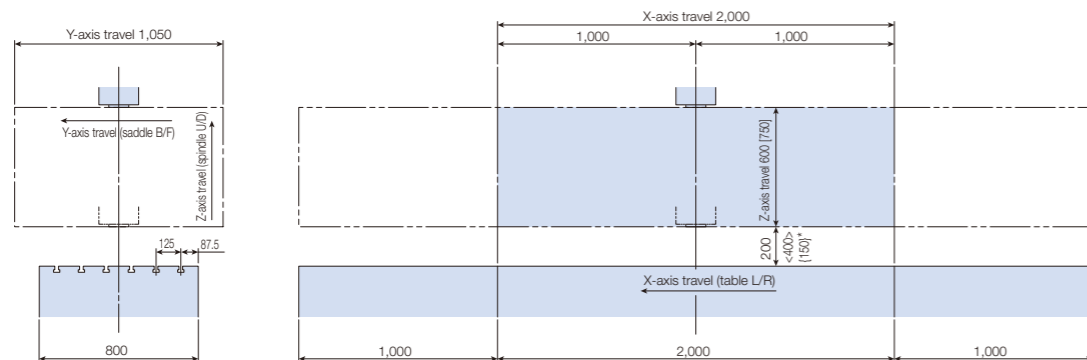

Dimensional and Installation Drawings

Unit: mm

MB-80V

X-axis travel: 1,600 mm

The dimensions in < > refer to those for specs with Z-axis travel of 750 mm

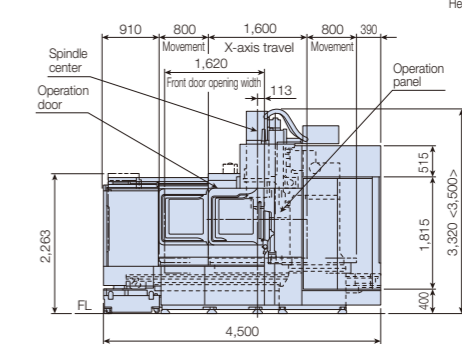
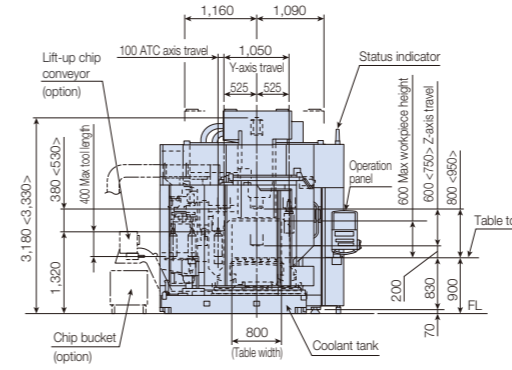
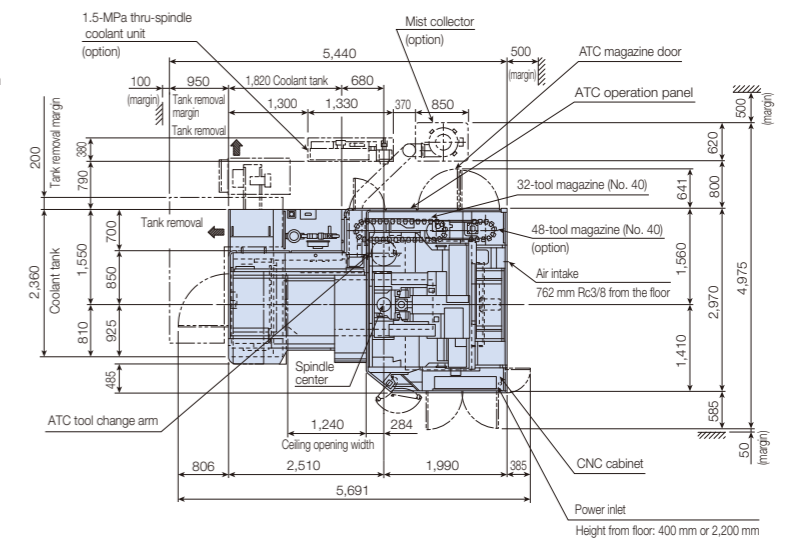

X-axis travel: 2,000 mm

The dimensions in < > refer to those for specs with Z-axis travel of 750 mm

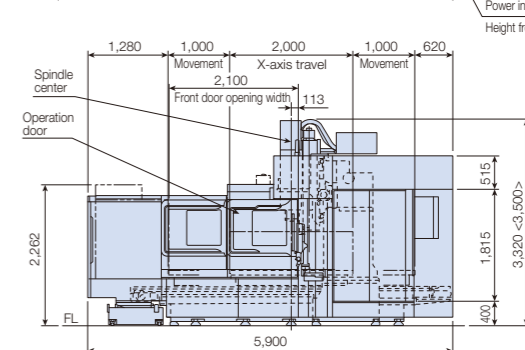
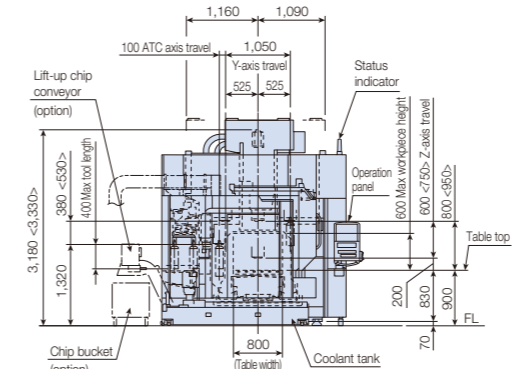
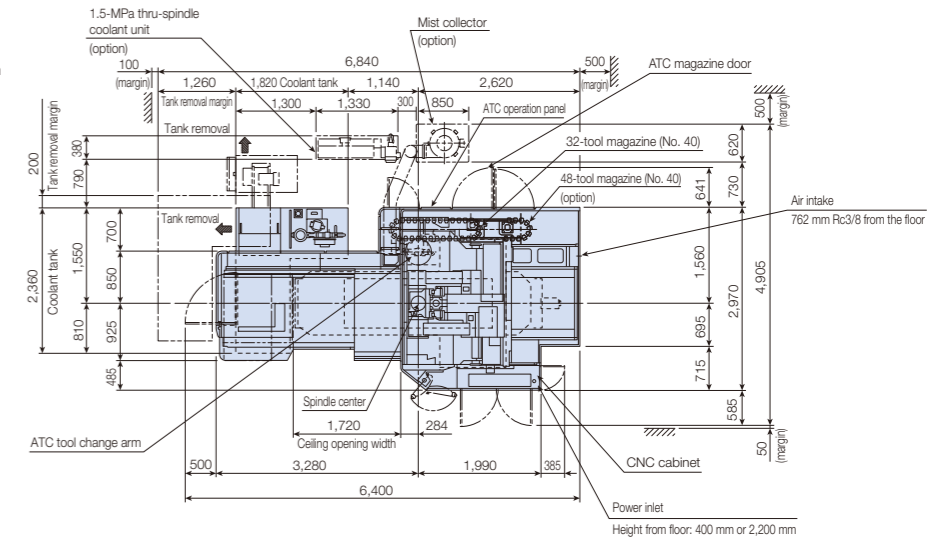





When using Okuma products, always read the safety precautions mentioned in the instruction manual and attached to the product.

● The specifications, illustrations, and descriptions in this brochure vary in different markets and are subject to change without notice.  
Pub.No. MB-80V\_100V-E-(1b)-200(Dec2025)D

This product is subject to the Japanese government Foreign Exchange and Foreign Trade Control Act with regard to security controlled items; whereby Okuma Corporation should be notified prior to its shipment to another country.



**OKUMA Corporation**

Oguchi-cho, Niwa-gun,  
Aichi 480-0193, Japan  
TEL: +81-587-95-7825 FAX: +81-587-95-6074