

# ***MB-VII Series***

***MB-46VII / MB-46VEII / MB-56VII***

Vertical Machining Centers



# MB-V II Series

MB-46V II / MB-46VE II / MB-56V II

Vertical Machining Centers

## Long-selling brand that is loved and evolving

Released in 2001  
More than  
**11,000** units  
were sold in total  
in the series

Selling a total of more than 11,000 units, the MB-V series has continuously evolved and supported the shop floor around the world for more than 20 years with high accuracy stability.

The MB-V II series improves on the basic functionality of the MB-V series with better cutting, more accurate cutting, and greater reliability in use, and it boasts further improvements in consistency of precision compared to past models.

It realizes both energy saving and high accuracy/productivity at a high level.

In addition, equipped with OSP-P500, a next-generation CNC that maximizes the factory utilization rate, the machine helps solve problems on the shop floor and social challenges faced by the manufacturing industry.



MB-46V II



MB-56V II

Photographs and images used in this brochure may include optional equipment.

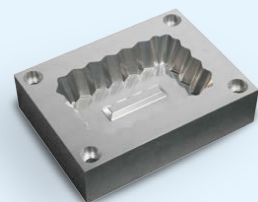

Dies and molds

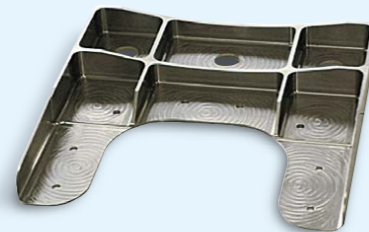

Aircraft parts

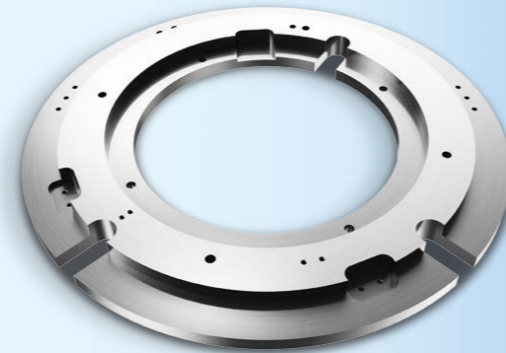

Semiconductor manufacturing  
equipment components

MB-46V II Special Website  
"Tomorrow's Manufacturing" as talked about by developers



OKUMA'S PURPOSE (the reason Okuma exists)

# Contributing to society with the power of manufacturing services

Based on the concept of "total responsibility," which means providing everything related to machine tools, from products to machining technology, Okuma takes advantage of our strengths as a manufacturer that develops NC controllers in-house. Okuma develops comprehensive manufacturing services to solve challenges and provide value creation in the manufacturing life cycle of individual customers.

Then, we aim to be a company that **solves social challenges**

in the global manufacturing industry, such as the declining working demographic and the realization of a carbon-free society, with the power of manufacturing services.

## Total responsibility

We have a wide range of products and provide everything from machine technology to control technology, from hardware to software, from products to machining technology, and from before-sales services to after-sales services.

**M-E-I-K**  
(Mechanics - Electronics - IT - Knowledge)  
merging technologies

Products for total responsibility



Smart machine



NC controller



FA system

## MB-VII Series

For the realization of a sustainable society

# More powerful solutions for addressing societal challenges



### Decrease in veteran machinists and transmission of skills

The Okuma Intelligent Technology that enables machines to autonomously maintain high accuracy stability

Very easy for even a beginner to use

Thermo-Friendly Concept P9

Smart OSP Operation P28

Collision prevention

Collision Avoidance System P31

Cutting condition search

Machining Navi P31

Detects signs of failure

AI Machine Diagnosis P32

### Increase in cyber-attacks

Robust security

OSP-VPSII P28

Achieving high accuracy and high productivity while achieving decarbonization and energy saving

**Green-Smart Machine**

**OSP-P500**

Realization of manufacturing DX (digital transformation)

### Decrease in the working population

Reduction of the burden of tank cleaning

Sludgeless Tank P22

Solution to labor shortage and increase in productivity

Automated system P23

### Responding to the diversification of needs and improving operating rates

Useful for a wider range of workpieces

Automated system P23

Faithful digital reproduction of machines and processes

Digital twin P27

### Climate change mitigation

The Okuma Intelligent Technology that enables machines to autonomously maintain high accuracy stability

Thermo-Friendly Concept P9

Reduction of coolant needing disposal

Sludgeless Tank P22

A system for an energy-saving society

ECO suite plus P29

## Okuma's comprehensive manufacturing services

### Technologies and products we provide



#### Solutions for manufacturing DX (digital transformation)

- Production management and operation monitoring using digital technology

#### Factory visualization to help increase the operating rate

In Okuma's next-generation automated factories "Dream Sites," all machines are connected via a network to visualize information about the factory such as the operation status, performance, and machining records. Digital technology is used to help increase productivity.



#### Provision of solutions for smart factories

- Smart manufacturing
- Automation that can be realized easily

#### Helping customers reinforce their manufacturing

While Okuma has provided products and services customized to individual customers over many years, mass-customization\*, which is Okuma's strength, is demonstrated in the Dream Sites and will be provided as a solution for smart factories.

\* Concept/mechanism to achieve customized products with productivity that is similar to that of mass production



#### Supply of smart machines

- Autonomous machine tool featuring both usability and high productivity

#### Providing the most suitable machines, machining methods, and production methods

Using our advantage of developing NC controllers in-house, as well as the performance of machines with extremely high-accuracy stability and machining capabilities, we provide the most suitable machines, machining methods, and production methods flexibly and quickly for a wide range of industries and applications.

## Offering comprehensive manufacturing services to help customers create value

# Achieving high accuracy and high productivity while achieving decarbonization and energy saving

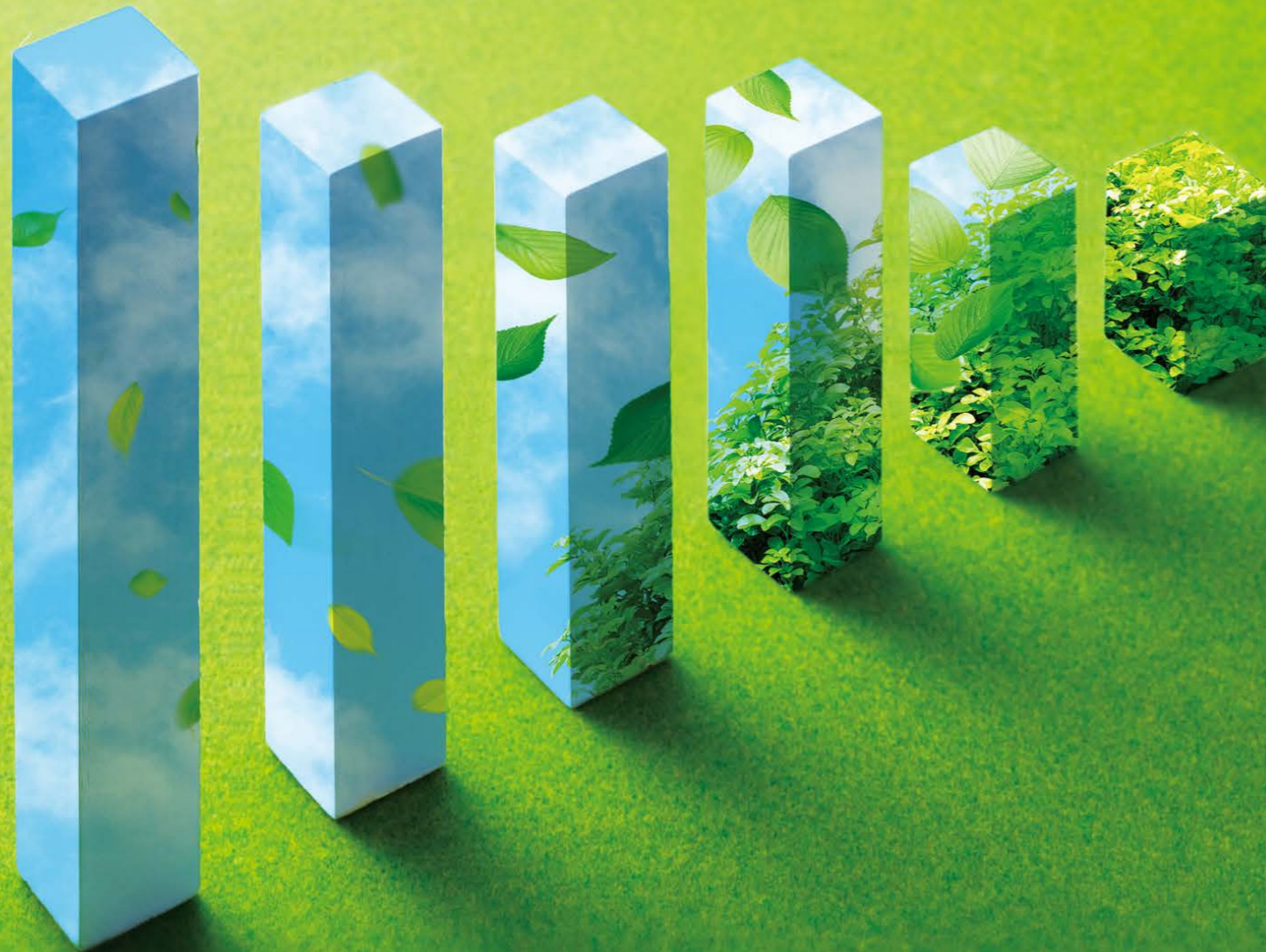

## Reducing energy consumption while maintaining stable high accuracy and high productivity

To work toward the realization of a carbon-free society, the industrial world is required to consider resources and the environment, and strengthen efforts to decarbonization.

Okuma will contribute to the realization of a carbon-free society and help make society sustainable by working to improve the basic performance of machine tools, such as high accuracy and high productivity, as well as energy efficiency.

We chose the name “**Green-Smart Machine**” for our machine tool that achieves high accuracy and reduced energy consumption autonomously and realizes high productivity. With Green-Smart Machines, we will contribute to the solution of social issues faced by the global manufacturing industry, together with our customers.

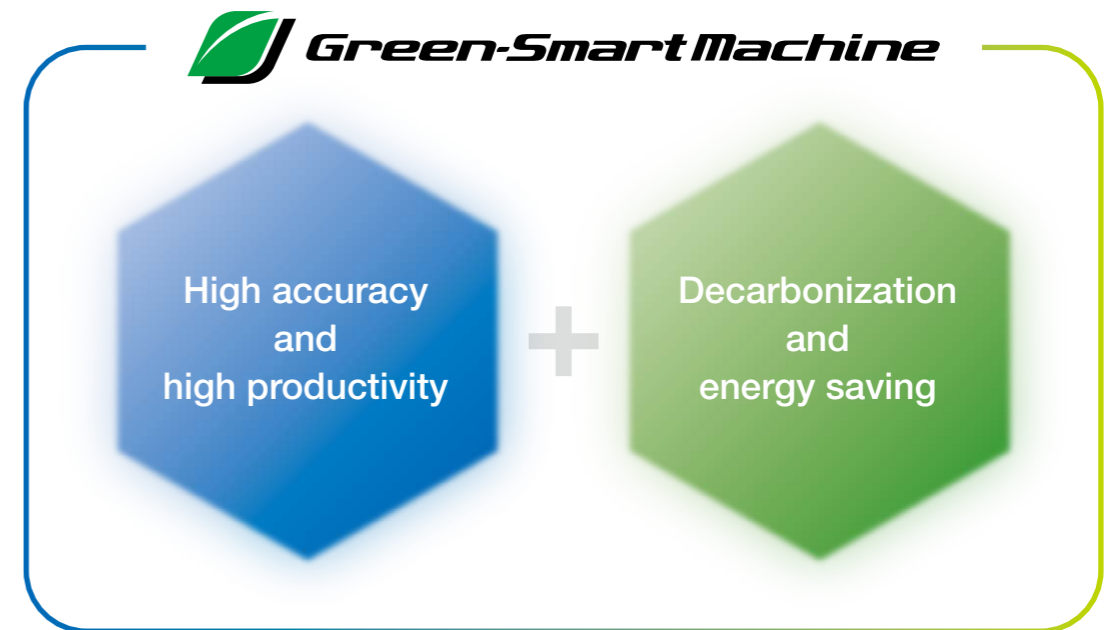

### Thermo-Friendly Concept

The Okuma Intelligent Technology that enables machines to autonomously maintain high accuracy stability

### ECO suite plus

A system for an energy-saving society

# The innovation that accepts temperature changes



## Thermo-Friendly Concept

The Okuma Intelligent Technology that enables machines to autonomously maintain high accuracy stability

### High accuracy can be achieved in normal factory environments

The machining accuracy of workpieces changes significantly due to the ambient temperature around the machine, heat generated by the machine, and heat generated in machining. The Thermo-Friendly Concept is a unique concept to “accept” such temperature changes so that high accuracy stability can be achieved in normal factory environments with no special measures taken by the user.



### Integrated machine design and control technology

In the Thermo-Friendly Concept, machine designs play the principal role. With simple machine construction and machine designs that equalize ambient temperatures, the machine deforms in a manageable manner and complex torsion or tilting is controlled to make the deformation predictable. Moreover, thermal deformation caused by changes in the room temperature, frequent spindle speed changes, and the temperature of the coolant are all controlled precisely with the highly accurate control technology by OSP, a controller developed by Okuma in-house. With the Thermo-Friendly Concept, manageable thermal deformation is accurately controlled to limit the behavior of dimensional changes, behavior which also matches the intuition of veteran machinists, within a stable range with high accuracy.

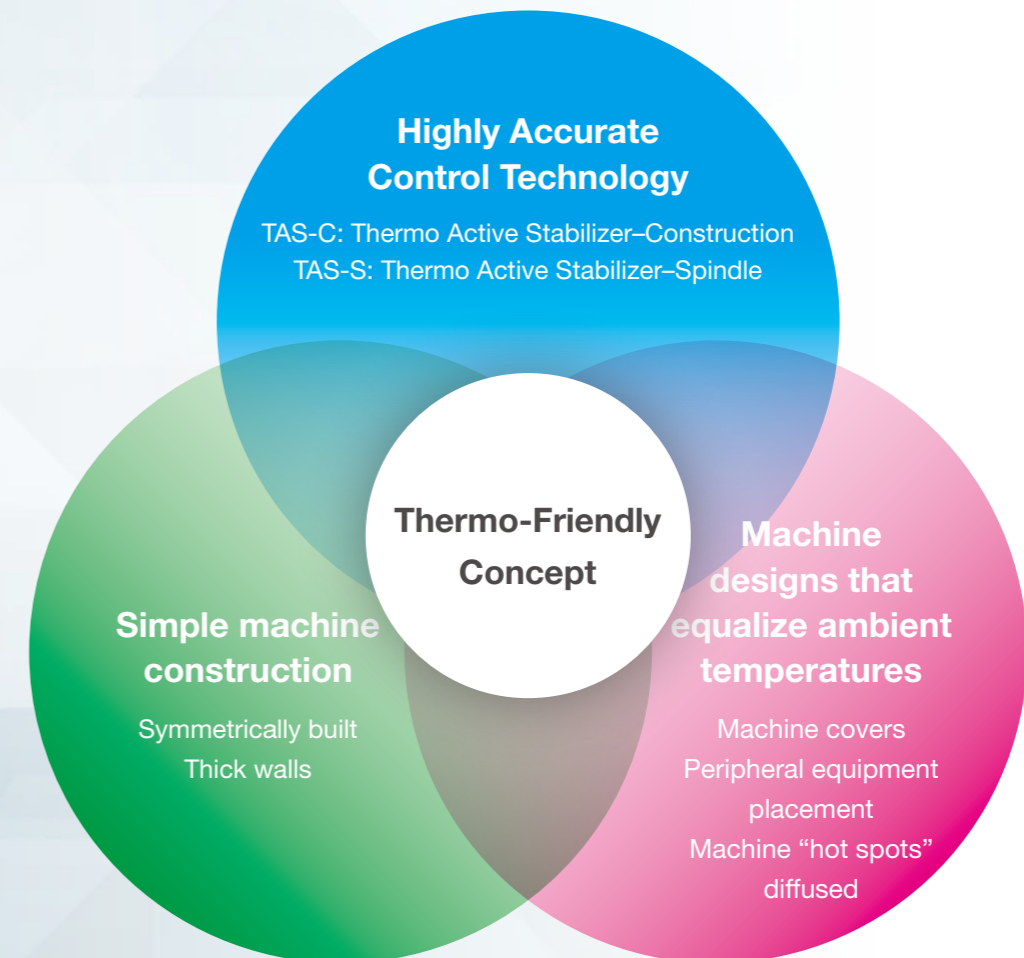

### We pursue our goal of seeing how much benefit we can bring to machine shops

With the aim of creating products that satisfy our customers worldwide, over more than 30 years Okuma has conducted a wide variety of testing in environmental test rooms, which can accommodate not only small machines but also large double-column machining centers. The massive amount of test data accumulated in those rooms served as the foundation of the Thermo-Friendly Concept, which has been applied to more than 62,000 machines. We will continue to pursue our goal of seeing how much benefit we can bring to machine shops, and work to develop products that can achieve high machining accuracy in all kinds of usage environments.

Outstanding dimensional stability greatly shortens compensation and warm-up time and improves productivity.

### The Thermo-Friendly Concept has further evolved

The Thermo-Friendly Concept is an Okuma Intelligent Technology intended to achieve amazing machining accuracy with unique structural design and thermal deformation control technology. It eliminates the need for cumbersome dimensional compensation and warm-up and demonstrates outstanding dimensional stability, even when operation continues over many hours or when the ambient temperature in the factory changes.



**Thermo-Friendly Concept**  
The Okuma Intelligent Technology that enables machines to autonomously maintain high accuracy stability

#### High accuracy is maintained autonomously and with superb stability Power consumption for maintaining the machining environment is reduced

The MB-V II series applies a more advanced version of the Thermo-Friendly Concept for better dimensional stability, with a structural design that is more advanced than ever. For the MB-46V II, the machining dimensional change over time has been reduced by 38% (from 8 μm to 5 μm) in comparison with conventional machines under typical factory conditions, maintaining high precision with greater stability than before. There is no need for a temperature-controlled room to keep a constant room temperature, so factory equipment costs and power consumption can be reduced significantly. Furthermore, the work time required for warm-up and dimensional compensation is substantially shortened to decrease power consumption and thereby reduce running costs. With the improvement of machining dimensional change over time to 5 μm in an environment with a room temperature change ranging over 8°C, the machining dimensional change over time can be limited to the same level as before even in an environment where the room temperature range is greater than before. Accordingly, the temperature setting of air conditioners can be more relaxed, yielding additional reduction in power consumption.

#### Machining dimensional change over time (actual data)

8 μm → **MB-46V II** 5 μm **Reduced by 38%**  
(conventional machine) in comparison with conventional machines

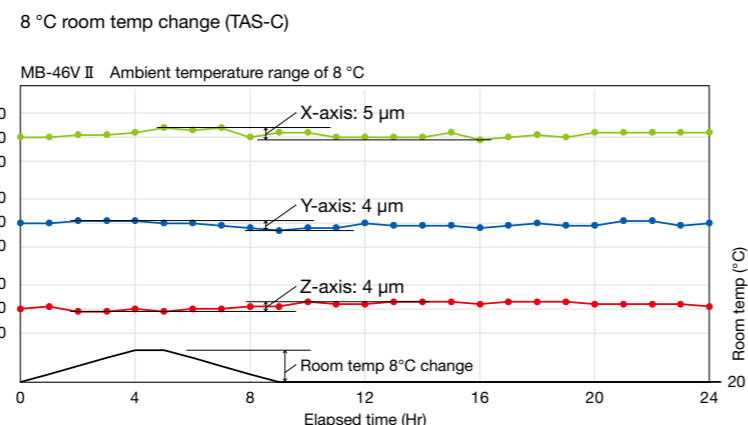

Note: The "actual data" referred to above for this brochure represent examples, and may not be obtained due to differences in specifications, tooling, cutting and other conditions.

#### TAS-C Thermo Active Stabilizer—Construction

When machining under changing ambient temperatures, machining dimensional changes are affected by expanding/contracting machine components as well as workpiece position with respect to the table in machining centers and workpiece size in lathes. TAS-C, based on machine thermal characteristics, with appropriately placed temperature sensors and feed axis position data, will predict and accurately control thermal deformation in machine construction when ambient temperatures change.

#### TAS-S Thermo Active Stabilizer—Spindle

Thermal deformation of the spindle changes greatly both when the spindle is turning and when it is stopped, affecting machining accuracy. TAS-S considers not only spindle temperature information but also spindle rotation, spindle speed changes, and spindle stoppage. Thermal deformation of the spindle is accurately controlled even when spindle speed changes frequently.

#### Outline of thermal deformation control (TAS-C, TAS-S)

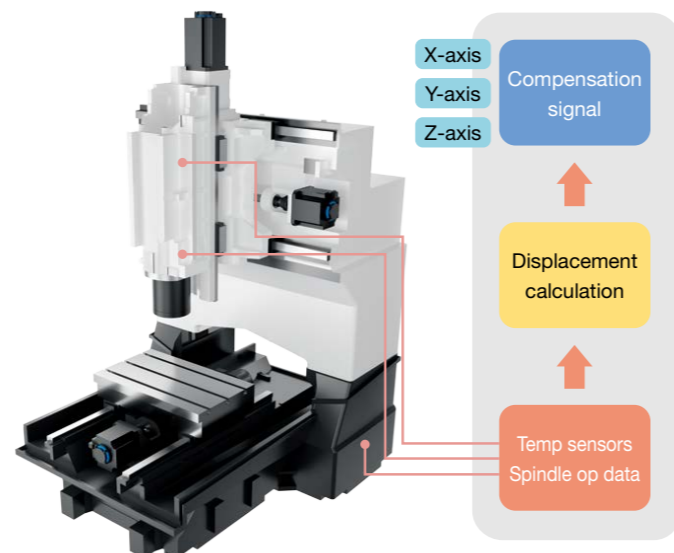

### Reliable machine structure that achieves machining with high accuracy and high efficiency

#### Reliable, highly rigid structural design

The overhang from the guideway of the linear axis to the machining point is small in the highly rigid double-column structure. The casting design optimizes the flow of loads that need to be supported, resulting in a lean, highly rigid structure.



#### Even higher accuracy

Fine vibration generated during linear axis movements is reduced by 60% by improving the casting structure and linear guide mounting parts, which reduces the impact on the machined surface quality to achieve machining with even higher accuracy.

#### Simple machine construction for thermal deformation / Machine designs that equalize heat transmission

"Manageable deformation"—structural designing for controlled machine expansion/contraction (predictable directions), with equalized heat transmission.

#### Enhanced Thermo-Friendly Concept

The machine structure has been improved to suppress tilting due to temperature changes on the cover side and the outside, and ensure that the heat capacity of the machine structure is well-balanced. As a result, machining accuracy is further increased.



### Achieving high-accuracy machining MB-46V II with AbsoScale; actual data (measurement method based on ISO 230-2)

#### The exactness of bi-directional positioning

X-axis (travel 560 mm)	<b>1.7 μm</b>
Y-axis (travel 460 mm)	<b>2.4 μm</b>
Z-axis (travel 460 mm)	<b>2.2 μm</b>

#### Bi-directional repeatability

X-axis (travel 560 mm)	<b>1.0 μm</b>
Y-axis (travel 460 mm)	<b>1.3 μm</b>
Z-axis (travel 460 mm)	<b>1.0 μm</b>

Note: The "actual data" referred to above represent examples of data obtained by using ISO 230-2 test methods done at Okuma factories, and they are not guaranteed values.

# High productivity Increase in productivity by shortening machining time with highly efficient machining

Applicable to a wide range of machining situations.

Machining ranging from parts machining to die/mold machining, and from machining of aluminum materials to difficult-to-cut materials, can be handled with a variety of spindles

No. 40 15,000 min<sup>-1</sup> 22 kW is adopted as the standard spindle

Cutting Capacity **504 cm<sup>3</sup>/min (30.744 in<sup>3</sup>/min)** (face milling, S45C)

Cutting Capacity **672 cm<sup>3</sup>/min (40.992 in<sup>3</sup>/min)** (end milling, S45C)

MB-V II series have adopted a 15,000 min<sup>-1</sup> (22/18.5 kW) spindle as the standard specification to improve finishing surface and shorten cycle time.

Material	Tool	Spindle speed min <sup>-1</sup>	Cutting Speed m/min	Feed rate mm/min	Cutting Width mm	Cutting Depth mm	Cutting Capacity cm <sup>3</sup> /min
S45C	ø80 face mill, 8 blades (cermet)	895	225	3,000	56	3	504
S45C	ø20 roughing end mill, 7 flutes (carbide), side	4,000	251	4,800	7	20	672
S45C	ø63 insert drill	720	142	108	—	—	—
S45C	Tap M30 P3.5	318	30	1,113	—	—	66% (Spindle load)

Note: The "actual data" referred to above for this brochure represent examples, and may not be obtained due to differences in specifications, tooling, cutting and other conditions.

No. 50 Productivity is even higher with a 12,000 min<sup>-1</sup> 33 kW high-power spindle (option)

Cutting Capacity **669 cm<sup>3</sup>/min (40.809 in<sup>3</sup>/min)** (face milling, S45C)

Cutting Capacity **740 cm<sup>3</sup>/min (45.140 in<sup>3</sup>/min)** (end milling, S45C)

**Roller bearing specifications** Our lineup includes the No. 50 12,000 min<sup>-1</sup> 33 kW high-rigidity, high-power spindle, which shortens cycle time and improves productivity. It can handle a wide variety of materials, performing highly efficient machining that maximizes the capabilities of your tools.

Material	Tool	Spindle speed min <sup>-1</sup>	Cutting Speed m/min	Feed rate mm/min	Cutting Width mm	Cutting Depth mm	Cutting Capacity cm <sup>3</sup> /min
S45C	ø100 face mill, 5 blades (carbide)	955	300	1,910	70	5	669
S45C	ø20 roughing end mill, 7 flutes (carbide), groove	4,200	264	10,000	20	3.7	740
S45C	ø80 insert drill	398	100	39.8	—	—	—
S45C	Tap M36 P4	212	24	848	—	—	107% (Spindle load)
A5052	ø63 face mill, 5 blades (carbide)	12,000	2,375	15,350	44	4	2,702
A5052	ø25 roughing end mill, 3 flutes (carbide), side	12,000	942	11,880	8	35	3,326

Note: The "actual data" referred to above for this brochure represent examples, and may not be obtained due to differences in specifications, tooling, cutting and other conditions.

## Standard spindle 15,000 min<sup>-1</sup> (No. 40)

Spindle speed:  
**15,000 min<sup>-1</sup>**

Max output:  
**22/18.5 kW**  
(30/25 hp)  
(10 min/cont)

Max torque:  
**199/146 N-m**  
(146/107 ft-lbf)  
(5 min/cont)

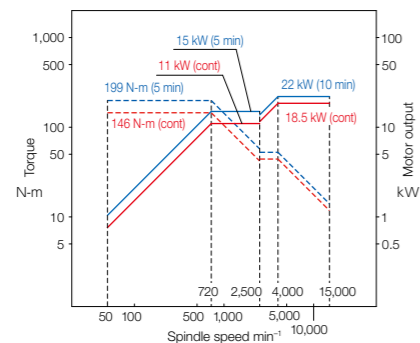

## High-power spindle 12,000 min<sup>-1</sup> (No. 50) option

Spindle speed:  
**12,000 min<sup>-1</sup>**

Max output:  
**33/26 kW**  
(44/35 hp)  
(10 min/cont)

Max torque:  
**302/148 N-m**  
(222/109 ft-lbf)  
(10%ED/cont)

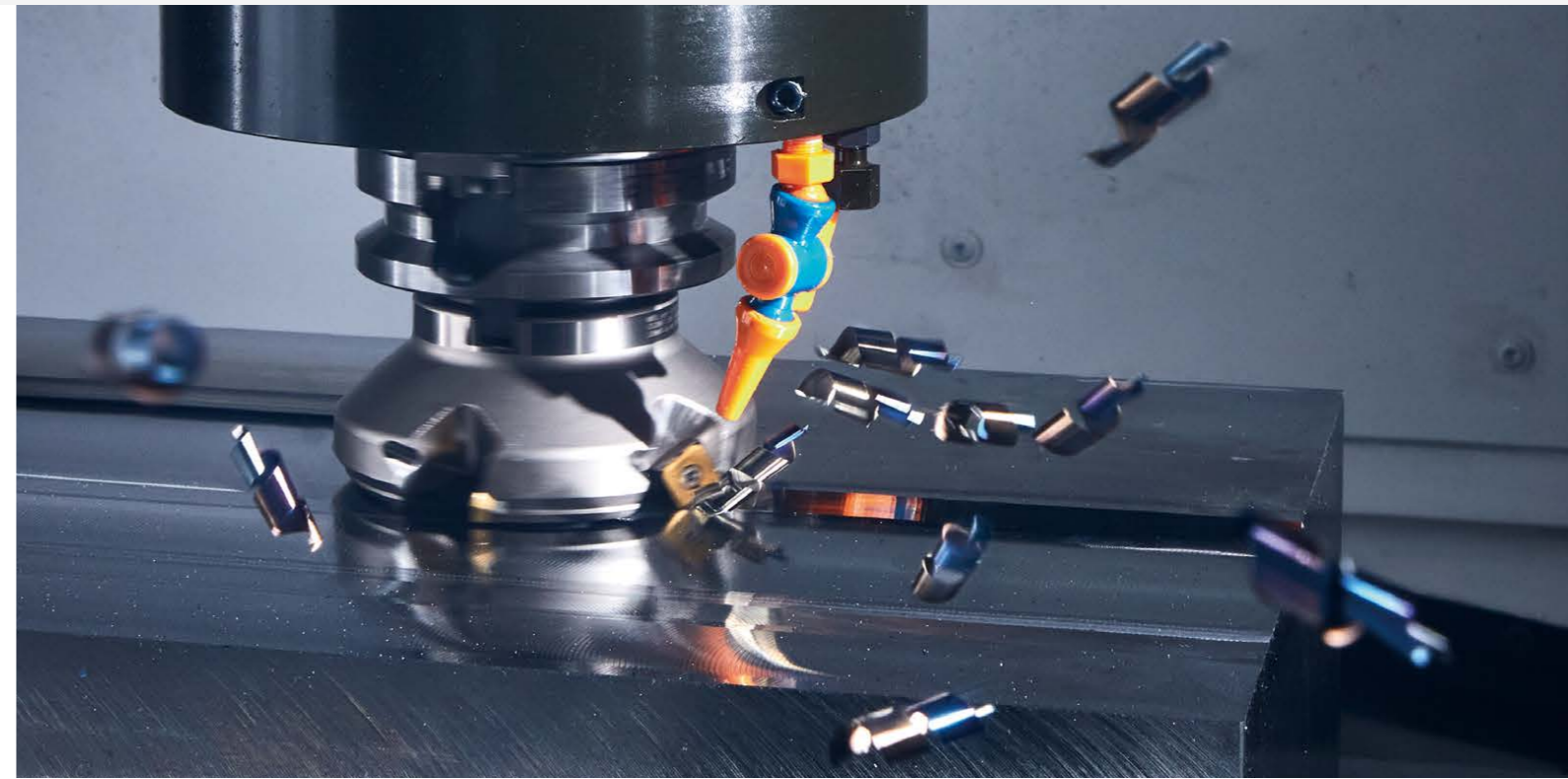
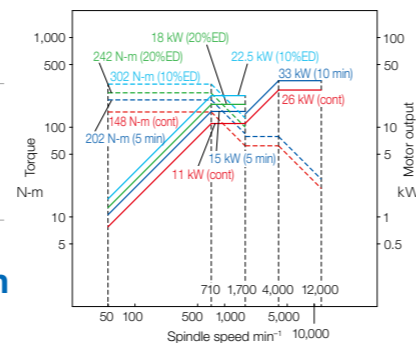

## Diverse spindle lineup

We have prepared spindles that are ideal for a wide range of machining situations experienced by customers, and fit with their machining purposes. The spindles are applicable to a variety of machining from parts machining to die/mold machining and from machining of aluminum materials to difficult-to-cut materials. Our new addition is the 30,000 min<sup>-1</sup> spindle, which has been used in MP-46V, a vertical machining center for high-precision parts and die/mold applications, and you can select from among a total of eight types of spindles.

No. 40	Wide-range	15,000 min <sup>-1</sup>	22/18.5 kW (10 min/cont)	199/146 N-m (5 min/cont)
	High-power	8,000 min <sup>-1</sup>	11/7.5 kW (10 min/cont)	198/135 N-m (5 min/cont)
	High-speed	20,000 min <sup>-1</sup>	30/22 kW (10 min/cont)	83/54 N-m (5 min/cont)
No. 50	High-power	6,000 min <sup>-1</sup>	11/7.5 kW (10 min/cont)	198/135 N-m (5 min/cont)
	Wide-range	12,000 min <sup>-1</sup>	26/18.5 kW (10 min/cont)	199/146 N-m (5 min/cont)
	High-power (roller bearing specifications)	12,000 min <sup>-1</sup>	33/26 kW (10 min/cont)	302/148 N-m (10%ED/cont)
HSK-F63	High-speed	30,000 min <sup>-1</sup>	15/11 kW (10 min/cont)	29.1/20 N-m (10 min/cont)
	High-speed	35,000 min <sup>-1</sup>	15 kW (cont)	4.09 N-m (cont)

Note: For the spindle lineup (spindle output and torque diagram), please refer to P38.

## Wasted time is eliminated to shorten machining time

### Cutting time and non-cutting time are shortened to increase productivity and reduce power consumption

The machining time can be shortened with an increase in the acceleration of the feed axis to reduce the cutting time, as well as with an increase in the rapid traverse and the reduction of the time for tool changes and other actions. The reduction of the machining time leads to an increase in productivity over the same amount of time and enables the saved time to be used for other operations. It also leads to the reduction of the power used for machining.

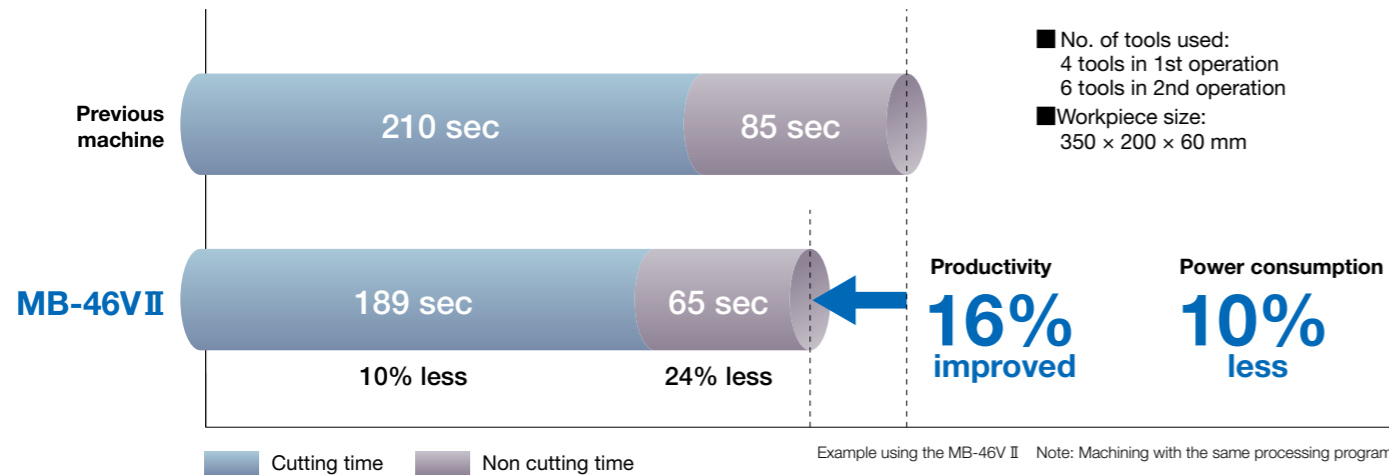
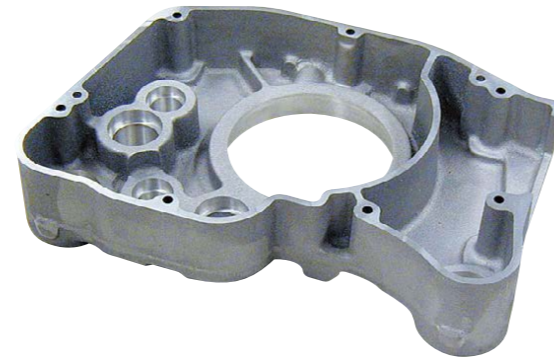

The **MB-56V II** shortens the time from the **311** seconds taken by previous equipment to **271** seconds.

**Productivity: 15% improved**  
**Power consumption: 10% less**

### Feed axis: Increase in rapid traverse

Axis	Previous machine	MB-46V II
X-Y axes	40	42 m/min (1,654 ipm)
Z-axis	32	36 m/min (1,417 ipm)

### Increase in acceleration

Parameter	Previous machine	MB-46V II
Acceleration	max 0.7	max 0.76 G

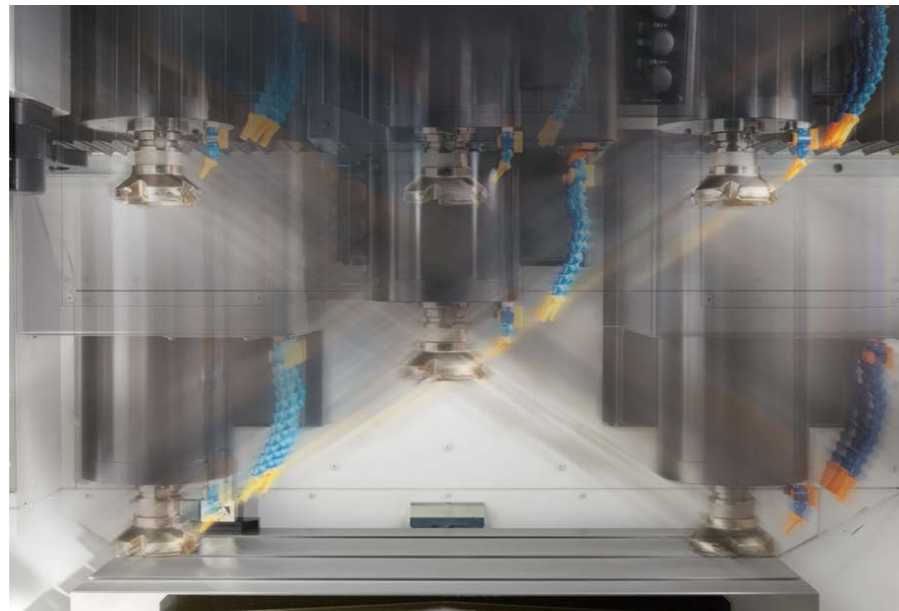

Photo shows the MB-46VE II  
\* E: Extension type

### An ATC electric shutter, which shortens non-cutting time and reduces power consumption, is installed as standard

Tool change time is shortened with faster opening/closing of the shutter

CTC min*1	<b>2.6 sec</b>	(MB-46V II No.40 spindle) 27% shorter*2
CTC min*1	<b>3.4 sec</b>	(MB-56V II No.40 spindle) 10% shorter*2
CTC min*1	<b>4.4 sec</b>	(MB-56V II No.50 spindle) 8% shorter*2

#### ATC shutter

The ATC shutter open/close time is shortened. Tool change time is shortened with the synchronous control of the shutter and the tool change arm.

Operating time is shortened by changing the ATC shutter from an air-driven type to an electric type. With the electric type, the position of the shutter can be grasped, so synchronous control of the shutter and the tool change arm eliminates wasted movements to shorten the tool change time.

ATC shutter open/close time is shortened

ATC shutter operating time	<b>0.5 sec</b>
----------------------------	----------------

Reduction of power consumption through the shift to electric shutters

ATC shutter Power consumption per opening/closing	<b>74% less</b>
---	-----------------

\*1. ISO 10791-9 (2001) (JIS B 6336-9) measurements  
\*2. Previous machine comparison

### Tool change time is shortened by reducing residual coolant discharge time

#### Suction of excess coolant in spindle option

A clean environment is maintained inside the magazine to reduce the frequency of cleaning.

Residual coolant in tools and spindles is removed instantly in 0.6 seconds (actual value for drill tools). The suction of coolant in spindles eliminates the need for air blowing to remove residual coolant from tools and spindles (at least 15 seconds), and so shortens tool change time. It also avoids the generation of mist due to air blowing, and prevents deterioration of the working environment. The frequency of required cleaning can also be reduced, easing the workload of operators.

Residual coolant suction time	<b>0.6 sec</b>
-------------------------------	----------------

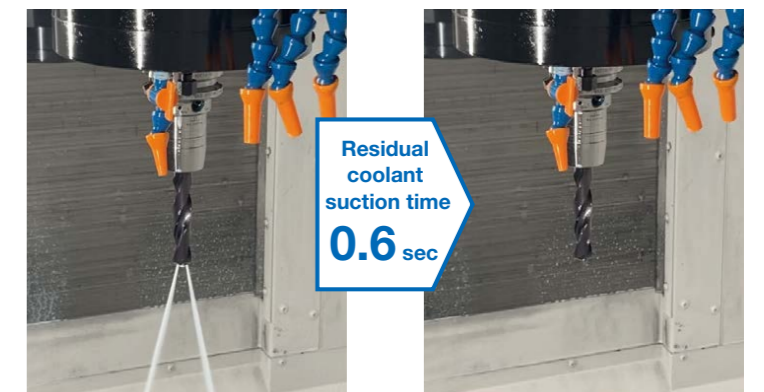

Residual coolant suction time  
**0.6 sec**

Ease of use with consideration of harmony between people and machines



**Easy-to-use operation panel with tilt mechanism**

**1 Swivel operation panel allows angle adjustment**

The panel position can be adjusted according to the height of the operator for comfortable operation.

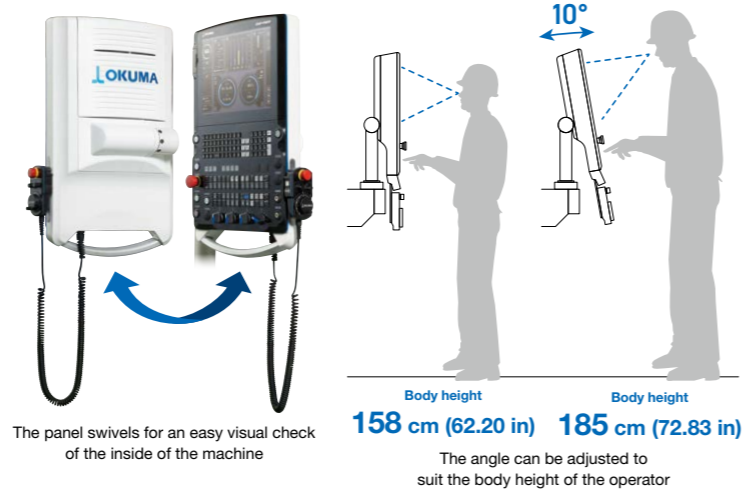

**Easy operation with the table positioned at an appropriate height and even better accessibility to the machine**

**5 Less work stress from workpiece handling and setup changes**

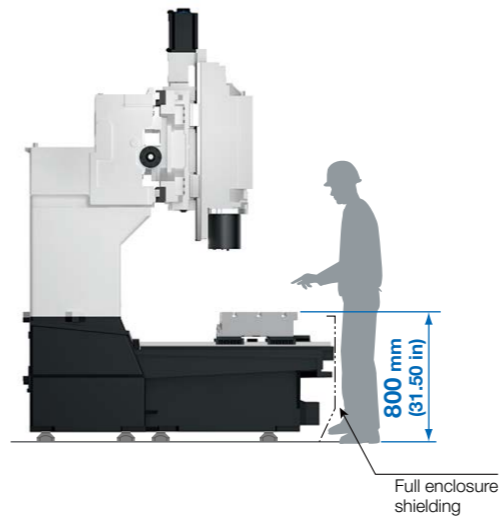

The shape of the cover at the bottom has been changed to reduce stress during setup and other operations. The operator can get closer to the machine without worrying about contact between feet and machine. In addition, when a workpiece is loaded using a hand lift, the lift can get closer to the machine with no need for concern about contact between it and the lower part of the machine. As with the previous machine, the table height is set to 800 mm to allow the operator to take a comfortable posture while working and reduce the setup burden.



**The opening is wide to facilitate easy operation. Heavy workpieces can be delivered with a crane**

**2 Wide opening for easy loading and unloading of workpieces**

The wide opening allows stress-free work when workpieces are loaded and unloaded.



Photo shows the MB-46V II \* E: Extension type

**3 Easy transportation of heavy workpieces by crane**

Even heavy workpieces can be brought in by crane, and workpieces can be set easily.



Photo shows the MB-46VEII

**4 Two interlocking doors for comfortable opening/closing operation (MB-56V II only)**

The smooth interlocking of the two operating doors makes the doors easier to open and close, reducing the burden on the operator.

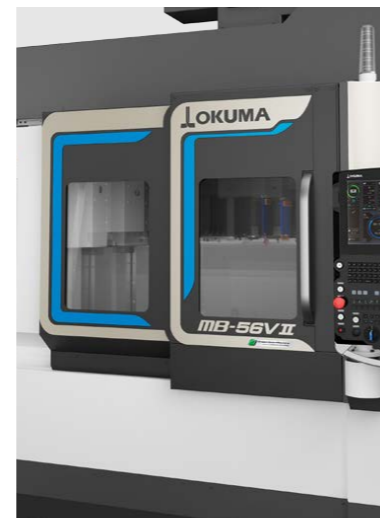

**The workflow and machining preparation time are shortened to reduce operator burden**

**6 Tools in the magazine can be exchanged from the front side of the machine**

Tools in the magazine can be exchanged from the operator's side, which reduces the operator's movement range and thereby shortens work time. A tool release lever stand for tool removal can be installed in the magazine to store tool release levers.

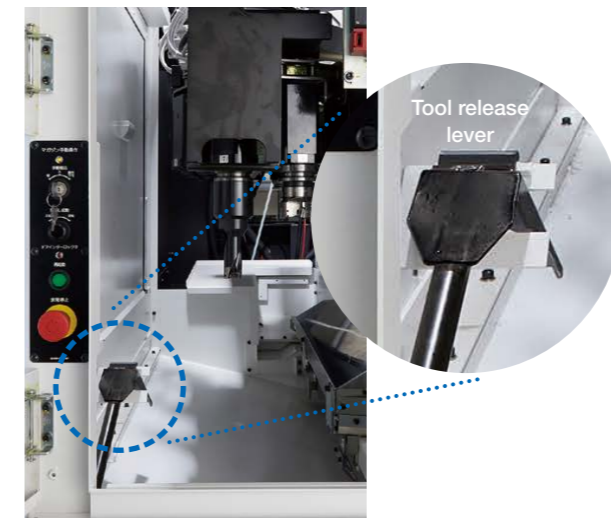

**7 Tools can be loaded/unloaded from spindle side**

A tool loaded/unloaded button is mounted on the spindlehead for easy tool load and unload.



**8 Maintenance concentrated in rear**

The lubricating oil tank and other items are centrally located at the rear of the machine for easy maintenance during daily inspections.



The use of the machine on the actual shop floor is considered. It has a high chip discharge capacity in response to its high machining capacity

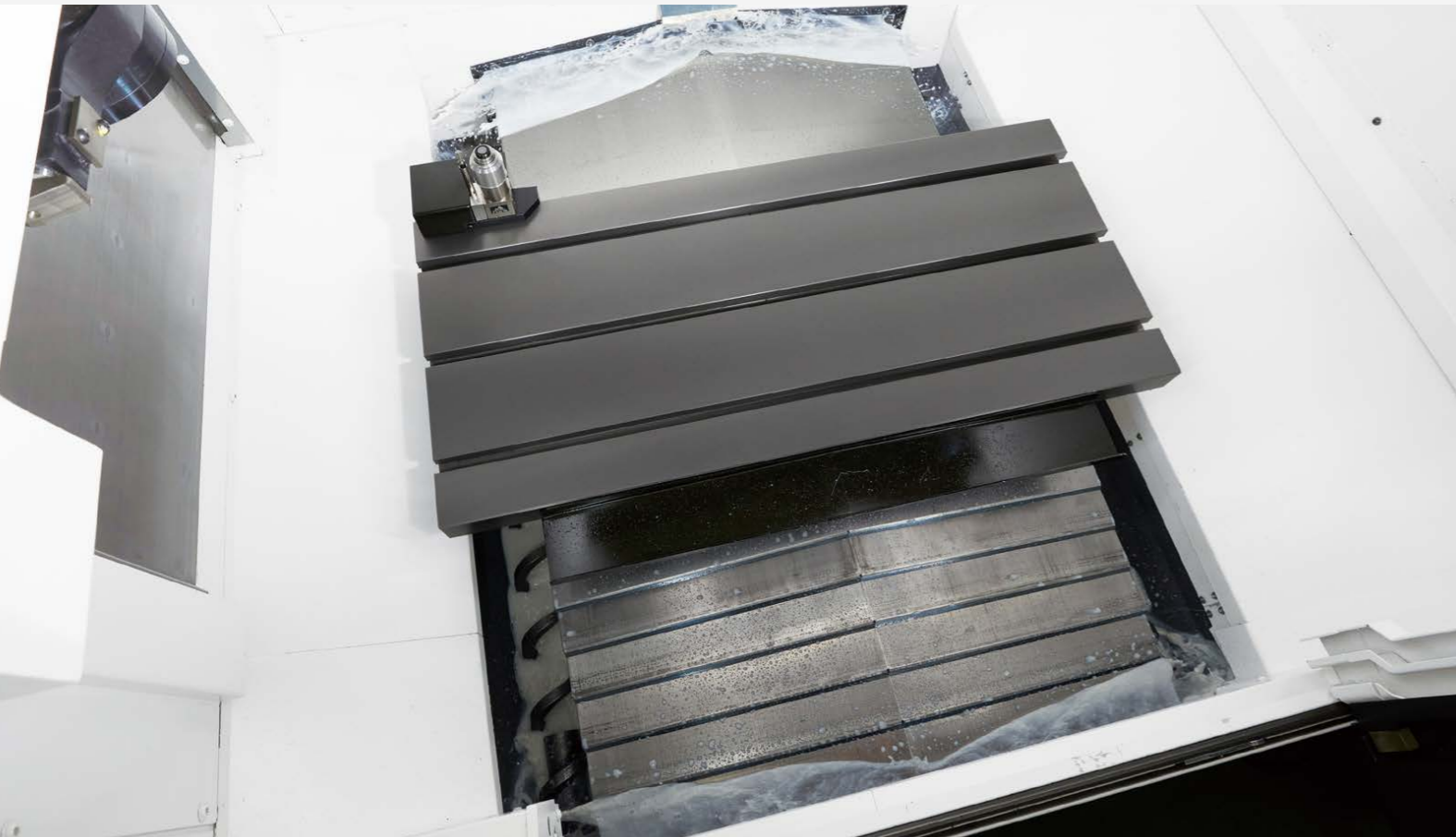
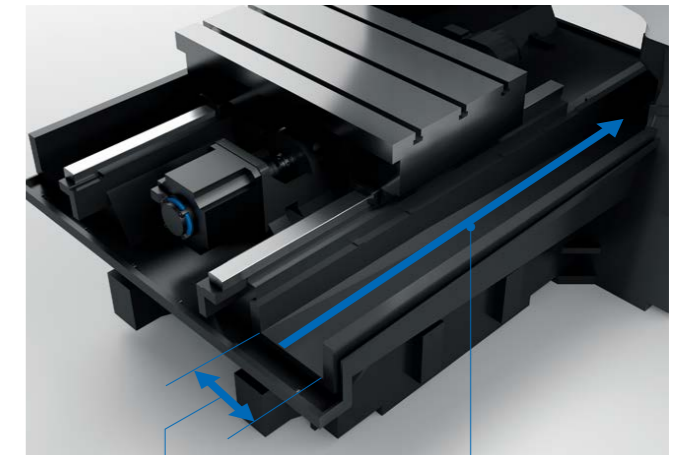
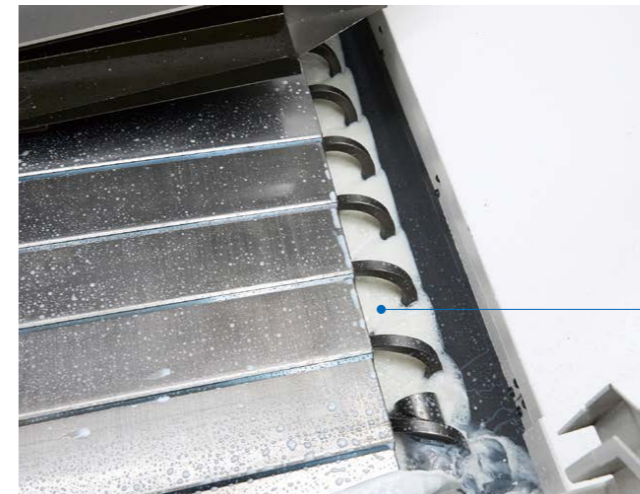

Photo shows the machining chamber of the MB-46VEII

### Significant improvement in the chip discharge capacity

#### In-machine chip conveyor (coil type)

A coil-type in-machine conveyor is installed as standard equipment. In addition, the coil diameter has been increased and the groove width has been widened compared to the conventional machine, which has greatly improved the chip discharge capacity and also reduced the frequency of chip cleaning. Chips are discharged in a straight line to off-machine chip discharge (lift-up chip conveyor, etc.) to avoid chip accumulation.



The discharge of chips is facilitated by widening the groove width and increasing the coil diameter.

Discharged in a straight line to the lift-up chip conveyor for off-machine chip discharge

### Single ATC shutter that prevents chip biting

#### ATC shutter

A simple structure with an electric single ATC shutter is used to prevent chip biting and achieve both high reliability and high speed. In addition, the shock caused by opening and closing the shutter, which is repeated during the use of the machine, is mitigated by the adoption of an electric type. It avoids problems caused by the shock that easily occur with an air-driven type and prevents machine operation from being interrupted.



### Prevention of chips from accumulating in the machine

The slope angle of the machine cover under the ATC shutter has been increased to prevent the accumulation of chips.



### Proper in-machine chip discharge that is also friendly to the environment

#### Cleaning of the Y-axis slideway cover

Environmentally friendly chip cleaning has been achieved by reviewing the coolant discharge part and the shape of the internal cover. The outlet is positioned exactly in the place where chips tend to accumulate, which reduces the amount of coolant used for cleaning and prevents the accumulation of chips in order to conserve the environment. With the discharge of chips, the frequency of cleaning inside the machine can be reduced, which also eases the burden on the operator.



Cleaning of the Y-axis slideway cover is included as a standard. The accumulation of chips on the front and back sides of the table is prevented, which allows operators to reduce man-hours for cleaning and also protects the wiper part.

Die/mold machining time is further reduced.  
The 30,000 min<sup>-1</sup> spindle has been added to the lineup



**The 30,000 min<sup>-1</sup> spindle (option) for high-speed, high-quality surface finishing of dies and molds, has been added to the lineup**

With the 30,000 min<sup>-1</sup> spindle for die/mold machining, machining time can be further reduced.

<b>30,000 min<sup>-1</sup> spindle</b>	option
<b>For high-speed, high-quality surface finishing of dies/molds</b>	
<b>Spindle speed</b>	<b>30,000 min<sup>-1</sup> (option)</b>
<b>Spindle type</b>	<b>HSK-F63</b>
<b>Max output</b>	<b>15/11 kW (20/15 hp) (10 min/cont)</b>
<b>Max torque</b>	<b>29.1/20 N-m (21/15 ft-lbf) (10 min/cont)</b>

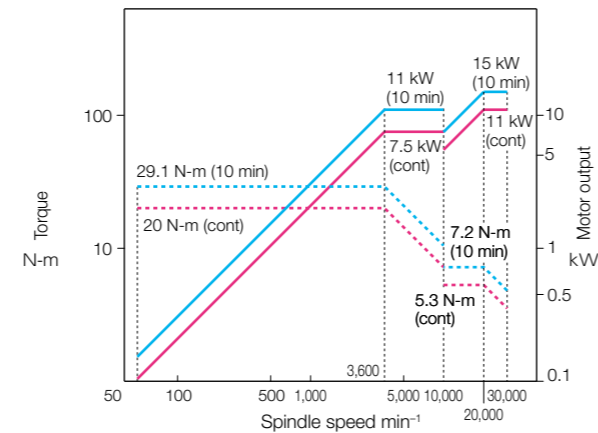

**Thermal deformation after tool changes is reduced significantly**

**Spindle shaft cooling**

With a spindle warm-up for just **3 minutes**, boundary errors can be lowered to **2 μm** (actual data)

Spindle shaft cooling stabilizes tool length by cooling the spindle to minimize temperature changes and decrease thermal deformation. Increases in spindle and tool temperature are inhibited, making higher accuracy machining possible. The cooling of the spindle also shortens its thermal deformation saturation time and can reduce warm-up. Boundary errors with different tools, such as in corner machining, are greatly reduced. This makes it possible to shorten the finishing time for dies and molds.

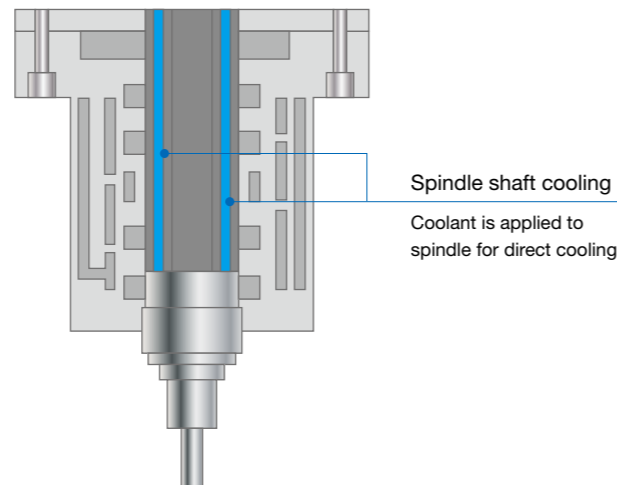

No repeat setup needed for additional machining



**In-process gauging to correct product accuracy (option)**

Workpieces are gauged in-process. As a result, even when additional machining is required after gauging, machining can be performed without changing the setup, which eliminates the need for repeat setup. With the auto tool length compensation device, the tool length is corrected automatically to reduce the burden on the operator. The auto tool length compensation device is installed in internal piping to avoid the entanglement of chips.

**Auto zero offset / Auto gauging** option

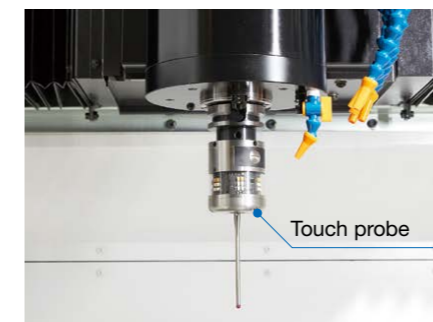

**Auto tool length compensation (contact)** option



**Auto tool length compensation (non-contact)** option



Various solutions are offered to reduce the operator's burden

## Saves space and accommodates longer operating periods when multiple tools are used

### Matrix magazine option

Even if a tool malfunctions when multiple tools are used, it can be replaced by a spare tool, enabling a longer operating period without human intervention.



Photo shows the MB-46V II

<b>Standard</b>	20 tools (chain magazine)
<b>Option</b>	32 tools (chain magazine)
	48 tools (chain magazine)
	Over 64 tools (matrix magazine)

A diverse lineup, including both chain magazines and matrix magazines, ensures the required number of tools.



## Arrangement for various hydraulic and pneumatic fixtures

### 13 ports option 13 total hydraulic and pneumatic ports

The machining chamber is equipped with ports for supplying hydraulic and pneumatic pressure to up to 13 fixtures (option). This has made it possible to flexibly use fixtures and automatically load and unload workpieces of various shapes. In addition, increases in the independent movements of fixtures have enabled the automatic loading and unloading of multiple workpieces by the robot. The piping for hydraulic and pneumatic feed ports passes beneath a cover that telescopes along the Y-axis without being exposed to the machining chamber. This prevents chips from accumulating on the pipes and eliminates interference with the robot, which occurred with conventional piping that was exposed to the machining chamber. The elimination of chip accumulation enables operation for longer periods of time and allows the robot to move freely inside the machine without restrictions.

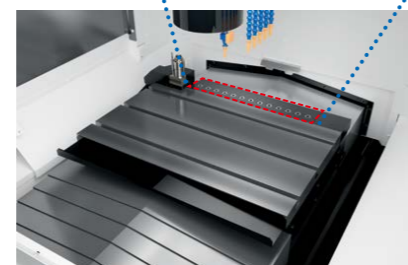
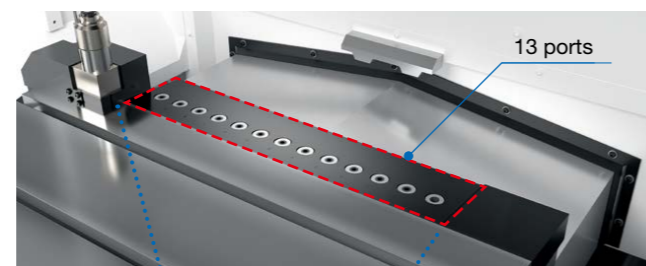

## Compatible with robots and auto pallet changers (APC) without reducing workability

The robot is installed on the right side of the machine using the auto open/close shutter (option) on the right side surface of the machine. Since the robot loads and unloads workpieces from the right side of the machine, automation can be achieved without impairing the worker's access to the inside of the machine from the front or reducing workability.

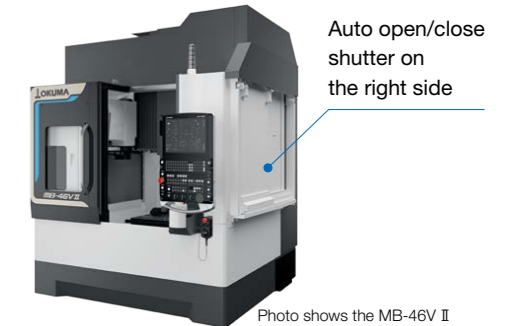

Photo shows the MB-46V II

## Troublesome coolant tank cleaning work is reduced dramatically to increase productivity. In addition, the environmental impact caused by the disposal of coolant is reduced.

### Sludgeless Tank option

It is important to remove impurities (sludge) contained in the coolant for the stable operation of the machine, and coolant tank cleaning is indispensable. The Sludgeless Tank (option) circulates coolant at a constant speed in the tank to effectively collect sludge even during non-machining while reducing defects caused by the sludge contained in the coolant, such as scratches on machined surfaces and troubles of cutters, as well. Sludge accumulation in the tank is suppressed, which also drastically reduces the frequency of troublesome tank cleaning and enables stable operation over long hours. In addition, the frequency of coolant replacement can be greatly reduced, which also reduces the environmental impact of coolant disposal. In the thru-spindle coolant specification (option), the bag filter collects even finer sludge to improve the quality of machined surfaces.

**Sludge removal rate** **99%** (when the material is casting and aluminum)  
Notes: After secondary filtration (cyclone filter) permeation  
 Okuma evaluated removal rate

**No coolant tank cleaning required for 3 years** (Okuma equipment actual data)

**No coolant replacement required for 3 years** (Okuma equipment actual data)

Note: It is necessary to select a chip conveyor with hinges + scraper (with drum filter) if the Sludgeless Tank option is chosen.

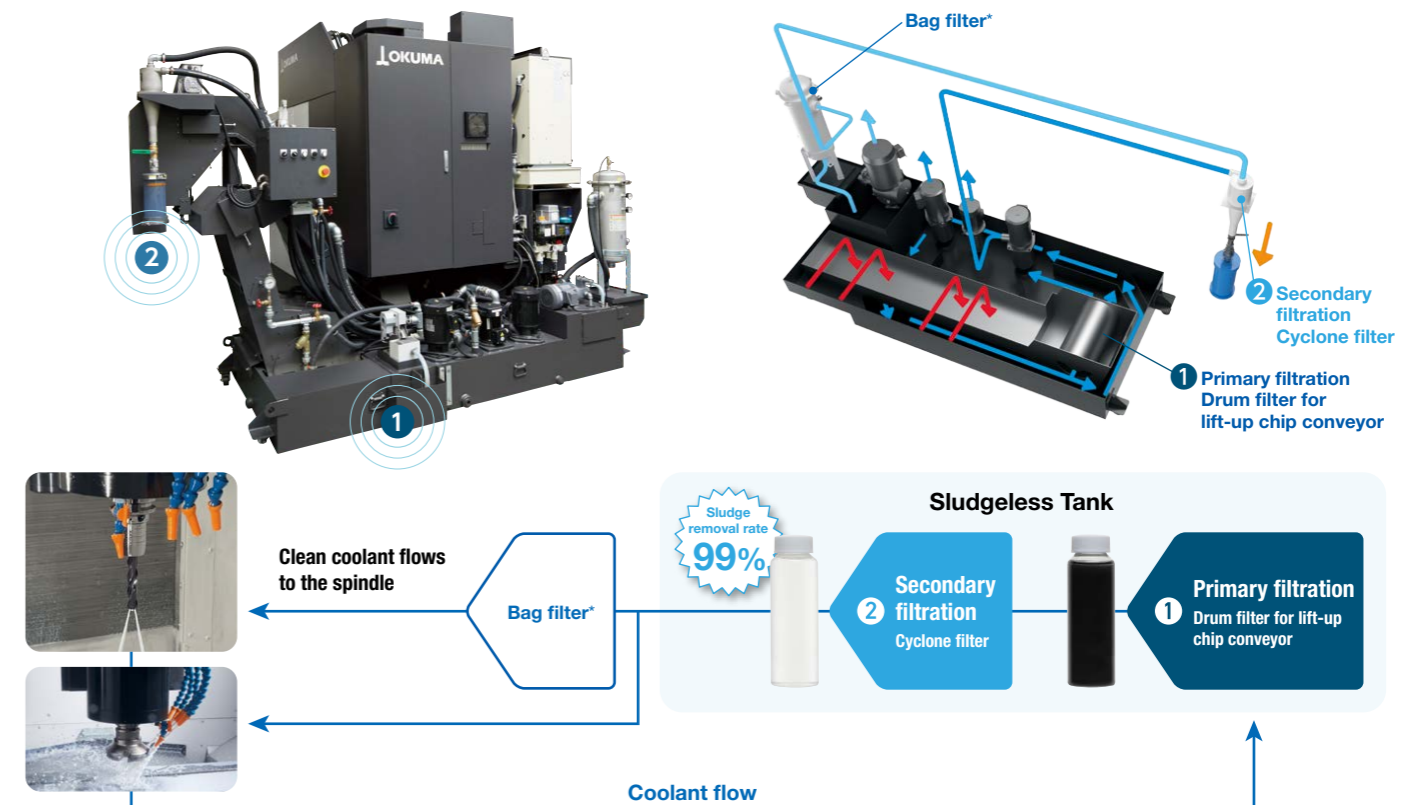

## Stable dimensional accuracy increases the productivity of the automated system



### Thermo-Friendly Concept

The Okuma Intelligent Technology that enables machines to autonomously maintain high accuracy stability

The Thermo-Friendly Concept has been applied to the MB-V II series in order to achieve dimensional consistency of precision that enables outstanding accuracy even for continuous machining over a long period of time. Even in an automated system composed of multiple machines, dimensional variation between the machines is small, saving labor for dimensional management and helping increase productivity.

## Workpiece changes are automated while saving space

### Auto pallet changer (APC) 2-pallet parallel shuttle option

This automated system saves space with the pallet changer positioned on the right side of the machine. By aligning the front of the machine with the front of the APC to secure a workflow line, the layout makes it easy to load and unload workpieces and operate the machine. Tool change and other ordinary tasks are concentrated on the front of the machine. Since it is possible to set up workpieces during machining, machine downtime is reduced to increase the operating rate.



Photo shows the MB-46VEII

Note: The MB-46VEII and MB-56V II have high-crossrail specs.

## An easy-to-operate robot system is installed in a compact space

### STANDROID

STANDROID is a simplified robot package that provides automation in high-mix low-/medium-volume production (HML/MV). Featuring easy robot operation and compact space, it has greatly lowered the barriers that have been faced by the introduction of robot automation. With good operability and the package designed to be suitable for the production operation, productivity for small and medium-sized lots, in addition to parts transportation, can be improved. Although there are restrictions on space, the number of stocks, and peripheral equipment, the robot system can be introduced in a compact space.

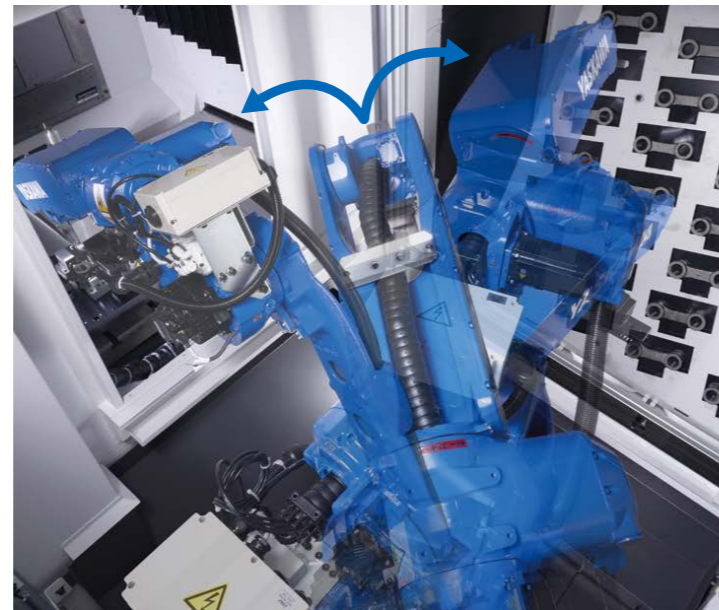

## Highly versatile and applicable to high-mix workpieces

### Robot system option

In this robot system, a stand-alone articulated robot is placed on the right side of the machine, and workpieces are loaded and unloaded from the auto open/close shutter on the right side of the machine. The system is highly versatile and widely applicable to high-mix workpieces and can meet the needs of customers who want to automate even high-mix, low-volume production or want to automate measurement, cleaning, and other tasks in addition to workpiece loading and unloading. The layout of peripheral devices can be set freely, and it is possible to transfer workpiece between different types of machines such as a lathe and a machining center. An automated cell with a high degree of freedom can be configured according to the customer's production operation.



Note: The images in the catalog are for illustrative purposes. The design and specifications may differ from the actual products.

Photo shows the MB-46V II

## A wide variety of peripheral devices (option) can be included in the automated system to achieve flexible production

The automation and manpower saving of production lines is supported by workpiece turnover and other devices that are indispensable for connecting processes. An optimal system can be configured with a wide variety of peripheral devices according to the customer's needs.

### Workpiece stand

The stand is used to adjust the posture of the material to be grasped by the hand. Re-grasping workpieces that tilt during stacking enables workpieces to be transported in a stable posture.



### Workpiece turnover device

This device turns workpieces over onto the reverse side. The gripper rotates 90 degrees and the table moves up and down to transfer workpieces. Reversing workpieces allows both sides to be machined.

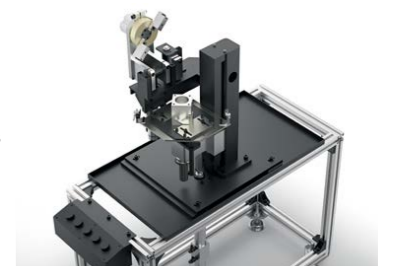

### NG chute

This device discharges materials and unmachined workpieces judged to be NG by seating detection. Each NG item is carried off on the inclined chute and its own weight causes it to be ejected.



### Air blower station

This device performs air-blowing cleaning of machined products. It cleans workpieces inside the device while gripping them with air-blowing to remove coolant and chips adhering to machined items.



### Phase determination device

This device detects the phase reference parts (spikes, notches, holes, grooves, etc.) on the outer periphery of workpieces, and stabilizes the workpiece supply phase to the machine. It is used for avoiding interference of the jaw part stop during chucking and for workpieces that require phasing during milling and other operations.



### Quality check station

This device discharges machined products for quality check.



A next-generation CNC that makes customer manufacturing DX (digital transformation) a reality

# OSP-P500

## Improved productivity and stable production

As Your Single Source for M-E-I-K (Mechanics - Electronics - IT - Knowledge) merging technologies, Okuma offers this CNC to build an advanced “digital twin” that faithfully reproduces machine control and machining operations and creates new value. In addition, the product helps improve productivity and realize stable production, featuring ease of use that allows customers to use their machining know-how. Additional features are: control technology that achieves high-speed and high-accuracy machining, energy-saving solutions that achieve both high accuracy/productivity and eco-friendliness, and robust security functions to protect against the increasing threat of cyber attacks.

15-inch operation panel



Home screen



Virtual machining

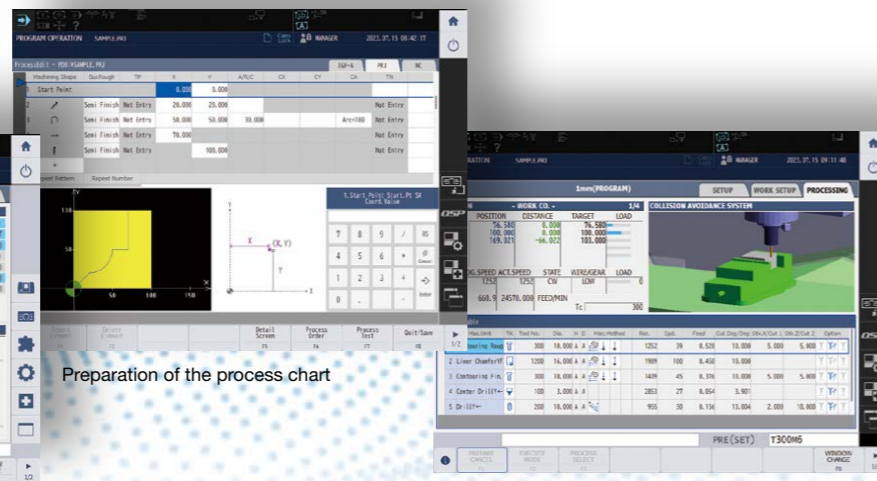

Preparation of the process chart

Operation with the process chart

1 Faithful digital reproduction of machines and processes

Ground-breaking concept of a digital twin

2 Realizing high-speed and high-accuracy machining

Revolutionary control technology

3 Reducing environmental impact  
Energy-saving solutions

**ECO suite plus**

4 Novice-friendly smart operation

Innovative operability

5 Increasing cyber resilience

Robust security

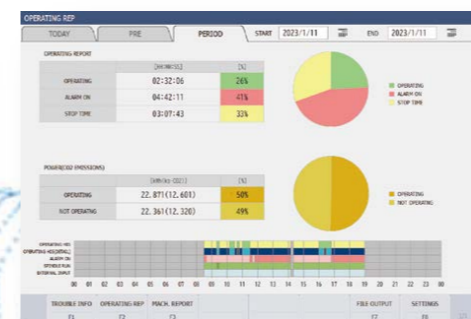

MacMan plus

**OSP-P500** A next-generation CNC that makes customer manufacturing DX (digital

transformation) a reality

**1 Faithful digital reproduction of machines and processes**

Digital Twin option

**Ground-breaking concept of a digital twin**

The digital twin calculates cycle time, machining shape, and electricity consumption through super high-speed and high-accuracy simulation. It supports accurate estimates of cycle time, development of the machining schedule, and quick and accurate estimates of delivery time and costs when an order is received.

Simulation using the latest machine information can be achieved even with an office PC or with the built-in OSP-P500. This enables preparation for machining in advance in the office environment (front loading).

Physical machine preparation time can be reduced by using digital twin preparation results to prepare for machining the next parts while machining continues. When a problem occurs on the shop floor, it can be solved quickly on site without going back to the office.

**Okuma's 2 digital twin systems**

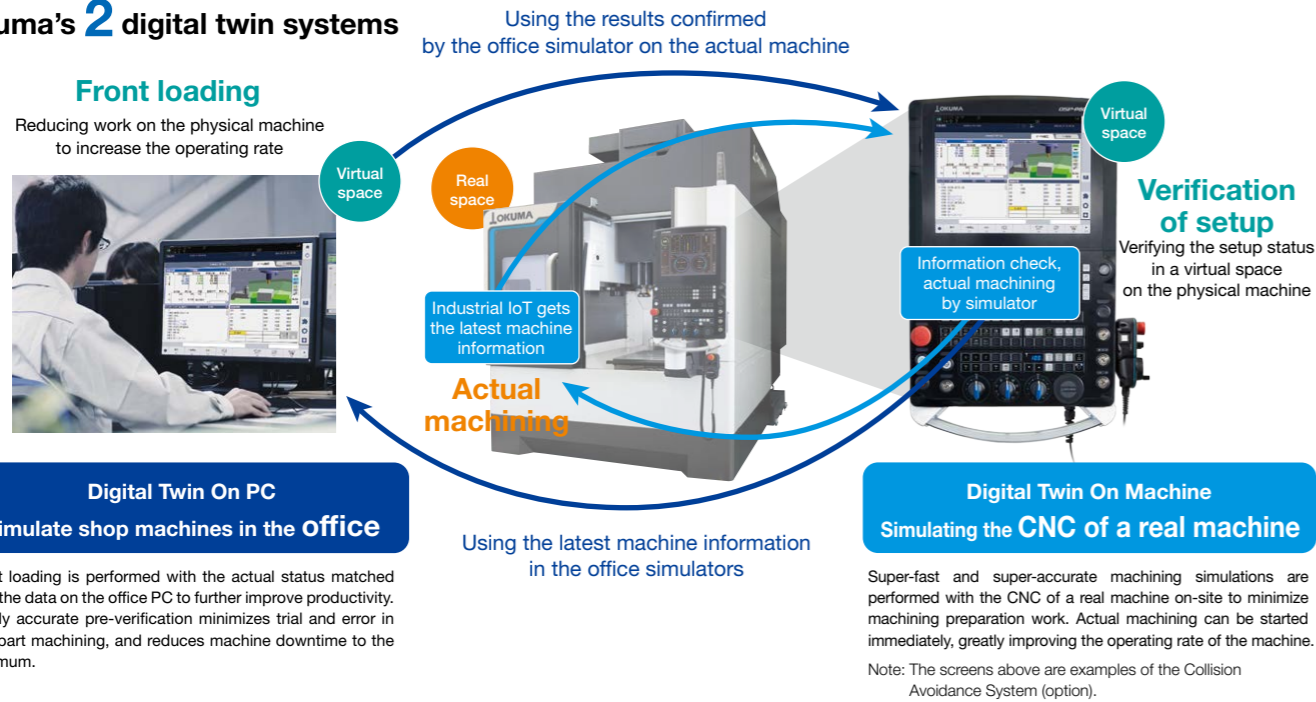

**2 Realizing high-speed and high-accuracy machining**

**Revolutionary control technology**

CNC operation performance has been doubled compared to the conventional model (OSP-P300A). The processing capacity and the response speed between control modules have been improved to shorten the machining time. The time for machining general parts can be shortened if the machining program and machining conditions are the same as before.

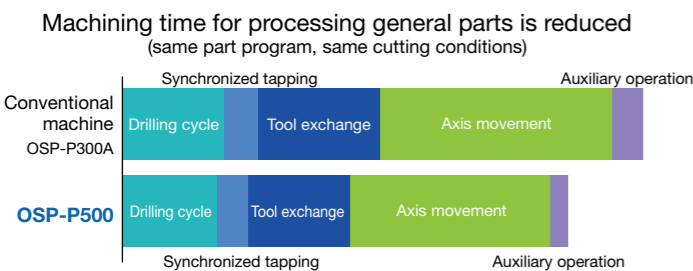

**3 Reducing environmental impact Energy-saving solutions**

**ECO suite plus**

"ECO suite plus" features the functions ECO Idling Stop, which allows the device to autonomously judge and shut down unnecessary auxiliary equipment, ECO Power Monitor, which gives visibility to carbon dioxide emissions, enabling these to be recorded and analyzed, and ECO Operation, which enables the optimized operation of peripheral equipment during machining. This is an energy-saving system that achieves both high accuracy, high productivity, and environmental friendliness to support improvement cycles for decarbonization.

For details, please refer to P29.

**4 Novice-friendly smart operation**

Smart OSP Operation option

**Innovative operability**

Conventionally, machining operations are programmed with G-/M-code based on drawings. With OSP-P500, however, you only have to follow the guidance to enter drawing information. So you can prepare for machining quickly, even if you have no familiarity at all with the NC program language.

**Operation without reliance on G-/M-codes enables easy, quick machining by anyone.**

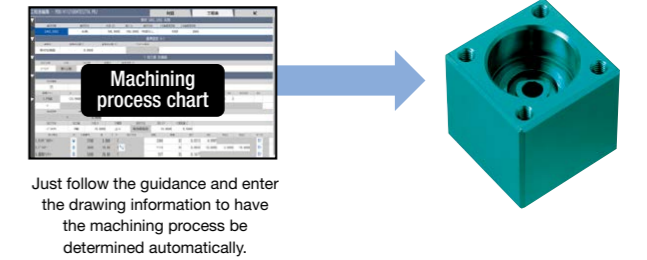

**High-productivity programs are easy to create**

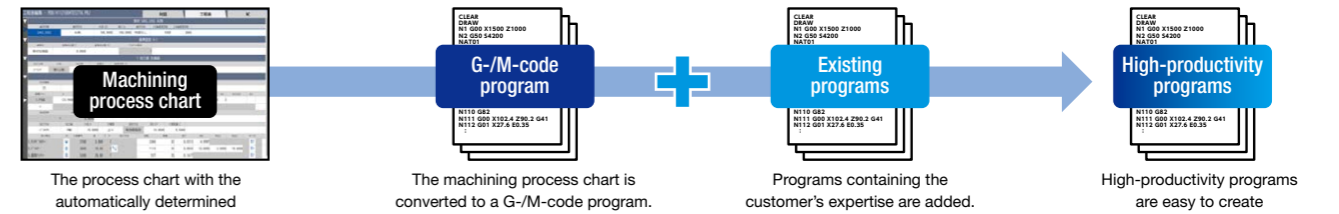

**5 Protecting the operation of machines and precious assets such as part programs from cyber attacks**

**Robust security that increases cyber resilience**

As digital networks develop and servers are increasingly connected to factory machines, the threat of cyber attacks increases, making it ever more important to protect against them. OSP-P500 is equipped with robust security functions for defense against and protection from cyber attacks, along with data restoration, to protect the operation of machines and precious assets such as part programs in the event of a cyber attack.

<b>Defense</b>	Prevent unauthorized access and connection	Identification of operators and communications, authentication function, etc.
<b>Protection</b>	Control damage	Anti-virus measures based on the allowlist, functions to prevent falsification and detect abnormalities, etc.
<b>Data restoration</b>	Preparation for emergencies	Control software and data backup function, etc.



**OSP-VPSII (Virus Protection System II)**

OSP-VPSII (Virus Protection System II) incorporates allowlisting\*1 antivirus functions into the Okuma CNC (OSP) to prevent infection by viruses via networks and USB devices.

**OSP-VPSII-STD**

OSP-VPSII-STD [Standard] includes antivirus functions developed exclusively for Okuma's numerically controlled machines. Machines can be used safely, as only software tested by Okuma can be run.

Note: Because the allowlist is locked, only Okuma software can be run.

**OSP-VPSII-EX (option)**

OSP-VPSII-EX [Expert] includes antivirus functions made by Trend Micro\*2. The allowlist can be edited by the customer, so any software can be installed\*3.

Note: Incorrectly editing the allowlist may prevent OSP from operating normally, so specialized knowledge of allowlisting antivirus functions is required.

\*1. Allowlisting is a method in which safe software is listed and software not included in the list is prevented from running.

\*2. Trend Micro is a registered trademark of Trend Micro Inc.

\*3. This does not guarantee the operation of any software on OSP. Note that installed software may prevent OSP from operating properly.

# Energy-saving technology

## Energy-saving solutions that reduce environmental impact

A system for an energy-saving society

# ECO suite plus

The "ECO suite plus" retains the concept of achieving both high machining accuracy stability and energy savings (less carbon dioxide emissions) achieved by the Thermo-Friendly Concept and the "ECO suite" that was put into practical use in 2014. It is an energy-saving system with enhanced high-accuracy/-productive functionality and advanced eco-friendly support.

## Ensure accuracy and actively turn off unnecessary peripherals

### ECO Idling Stop

All auxiliary equipment when not needed (most of factory power consumption), can be turned off. The ECO Idling Stop button enables diligent idle stop operations even during machining and maintenance work. The cooling system necessary for maintaining accuracy uses Thermo-Friendly Concept technology, and the machine itself decides when to cool and stop idling while maintaining high accuracy. With ECO suite plus, the machine automatically detects the operating status, eliminating the need to push buttons while reducing carbon dioxide emission as much as possible without operator awareness.

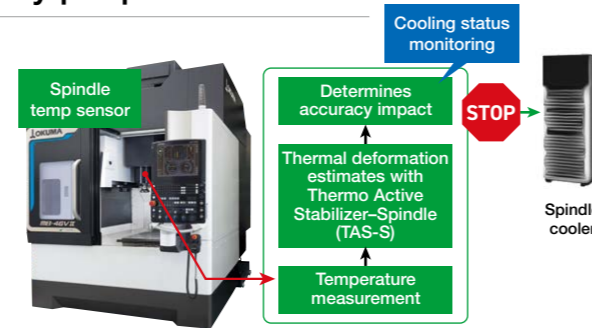

## Peripheral equipment runs only when needed

### ECO Operation

By using only the required peripherals (chip conveyors, mist collectors, etc.), energy-saving operations that also maintain high productivity are possible.

ECO suite plus enables more detailed tuning of operations to thoroughly support carbon dioxide emission reduction activities that do not reduce productivity.

ECO PARAMETER	ECO IDLE STOP (1/4)	ECO OPERATION
ECO IDLE STOP ELAPSED TIME	000:00:00	REMAINING TIME UNTIL ECO IDLE STOP READY 12:45
Chip conveyor interval control	OFF	PARAMETER UNIT
Chip conveyor interval active time	100	[min]
Chip conveyor interval suspended time	200	[min]

## Confirming energy savings and analyzing reductions

### ECO Power Monitor

Making it possible for the OSP control to analyze the operating status of each device.

The decarbonization cycle on the shop floor is supported through the three phases, 1. View, 2. Record, and 3. Analyze.

### 1 Check carbon dioxide emissions on the spot

With ECO suite plus, you can also check the power consumption of each device.

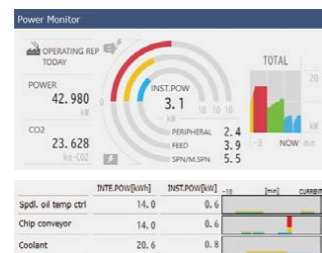

### 2 Simultaneously records operating status and carbon dioxide emissions

With ECO suite plus, recording carbon dioxide emissions for each device, and data output is possible.



### 3 Analyze carbon dioxide emissions and improve machine tool operation

With ECO suite plus, not only the display on the machine but data analysis for each device is also possible on a PC, to see a more detailed carbon dioxide emission analysis.

Example of utilizing One-Touch Spreadsheet (option) to create visual feedback of machine's power consumption and carbon dioxide emissions.

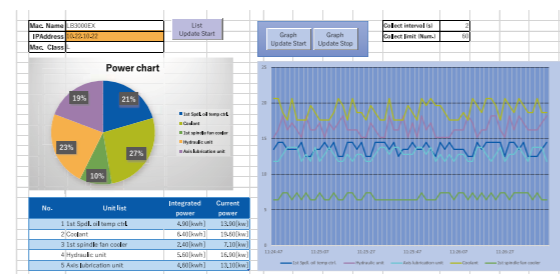

# Environmental effects

The product has excellent environmental performance to reduce power consumption and help mitigate climate change (decarbonization)

Achieving high accuracy and high productivity while achieving decarbonization and energy saving



Shortening machine operation time to minimize power consumption while maintaining machining accuracy

## High accuracy and high productivity

The Okuma Intelligent Technology that enables machines to autonomously maintain high accuracy stability



## Thermo-Friendly Concept

Thermo-Friendly Concept energy savings

Temp control:  $\pm 2^{\circ}\text{C} \rightarrow \pm 5^{\circ}\text{C}$

Yearly: **41 t-CO<sub>2</sub>/unit Less**



High accuracy stability even at 1/3 less air conditioning electricity.

Note: Estimates: machine shop with 4 machines installed

## Decarbonization and energy saving

A system for an energy-saving society

# ECO suite plus

Further reductions in carbon dioxide emissions from energy-saving machine tools

**10% Less**

Power consumption [kW-h/yr]

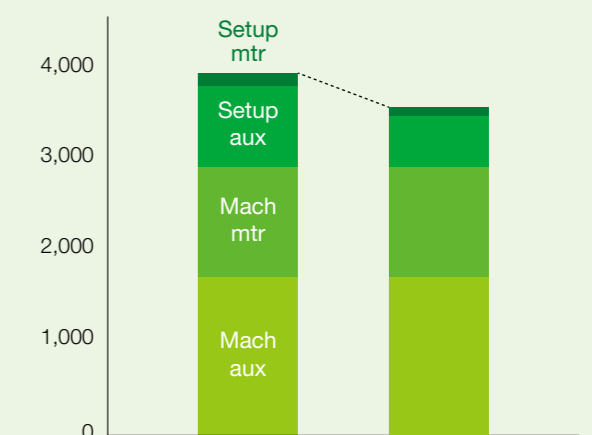

MB-46V II  
Power Regeneration  
+  
Thermo-Friendly Concept

MB-46V II  
Power Regeneration  
+  
Thermo-Friendly Concept  
+  
ECO suite plus

[Calculations]  
MB-46V II 50% utilization (8 hr/da, 20 da/mo, 1 yr)  
Assuming 75% of non-operation time used ECO Idling Stop

# Technologies for energy saving

## Various advanced technologies that increase productivity

### Allowing operators to focus on making parts



**Collision Avoidance System**  
Collision prevention option

CAS prevents collisions in automatic or manual mode, providing risk-free protection for the machine and great confidence for the operator.

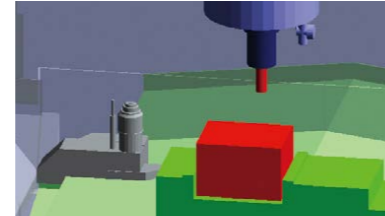

### Achieves long term accuracy and surface quality



**SERVO NAVI**  
Optimized Servo Control

#### Cycle time shortened with faster acceleration

**SERVO NAVI AP (Automatic Parameter setting): Work Weight Auto Setting**  
On table travel type machining centers, the table feed acceleration with the previous system was the same regardless of weight, such as workpieces and fixtures loaded on the table. Work Weight Auto Setting estimates the weight of the workpiece and fixture on the table and automatically sets the linear axis servo parameters, including acceleration, to the optimum values. Cycle times are shortened with no changes to machining accuracy.

#### The workpiece weight and acceleration relationship

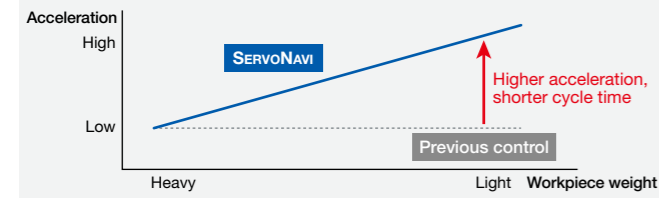

### Maintains machining accuracy and surface quality

**SERVO NAVI SF (Surface Fine-tuning): Reversal Spike Auto Adjustment**  
Slide resistance changes with length of time machine tools are utilized, and discrepancies occur with the servo parameters that were the best when the machine was first installed. This may produce crease marks at motion reversals and affect machining accuracy (part surface quality). Reversal Spike Auto Adjustment maintains machining accuracy by switching servo parameters to the optimum values matched to changes in slide resistance.

### Contributes to longer machine life

**SERVO NAVI SF (Surface Fine-tuning): Vibration Auto Adjustment**  
When aging changes machine performance, noise, vibration, crease marks, or fish scales may appear. Vibration Auto Adjustment can quickly eliminate noise and vibration even from machines with years of operation.

### Adjust cutting conditions while monitoring the data



**Machining Navi M-gII+**  
Cutting condition search for milling option

Based on the chatter noise captured by the microphone, Machining Navi displays a number of optimal spindle speed possibilities on the screen. The operator can change to the indicated spindle speed with a single touch and immediately confirm the result.



**Machining Navi M-i**  
Cutting condition search for milling option

Chatter vibration is measured by built-in sensors, and Machining Navi automatically changes spindle speed to the optimum speed.

#### Vibration waveform display

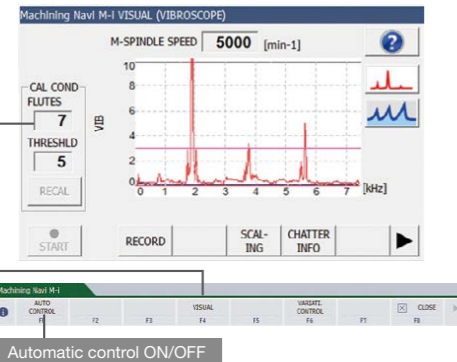

This sign indicates a change to the optimum spindle speed.

This sign indicates that spindle speed is being changed.

This sign indicates that the cutting load needs to be reduced.

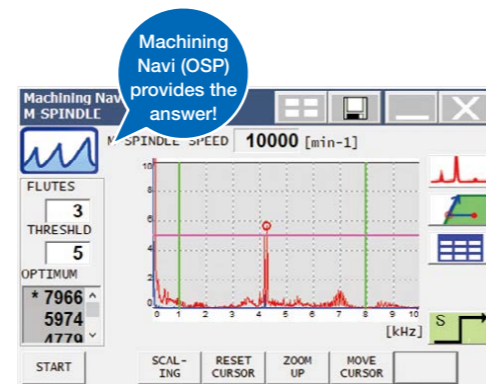

### Detect signs of spindle bearing and ball-screw failure, and reduce downtime



**AI Machine Diagnosis Function**  
Detects signs of failure option

Machine tool self-diagnosis technology "AI Machine Diagnosis Function" can detect signs of failure. Machine downtime can be reduced by preventing machine shutdown. The OSP-AI installed in the CNC identifies the presence or absence of any abnormality in the spindle and feed axis and the location of the abnormality and detects damage to the ball-screw support bearing and wear of the ball-screw\*.

#### Detects damage to spindle bearings

**AI Spindle Diagnosis Function**

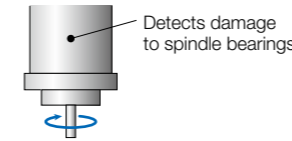

#### Detects damage to ball-screw support bearings, and ball-screw wear\*

**AI Feed Axis Diagnosis Function**

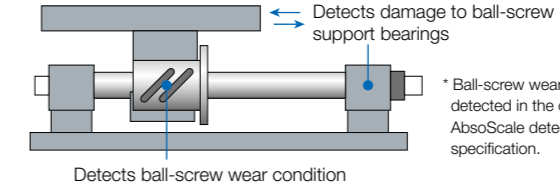

\* Ball-screw wear can be detected in the case of AbsoScale detection specification.

Note: It comes with pre-trained AI diagnostic models already installed, so diagnoses can be performed by the machine itself. AI diagnostic models can be updated through Okuma's Connect Plan.

### Improving the performance of machining dies and free-form surfaces

**Hyper-Surface II** option

The performance of machining dies and free-form surfaces is improved with axis control that is optimal for the machining shape based on advanced digital technology. In addition, irregular width of tool marks in shuttle machining is avoided to improve machining surface quality and also reduce machining time.

#### Finishing of die machining

[Axis control optimal for the machining shape]

- Controlling vibration without slowing down for corners
- Shortening machining time while also improving surface quality

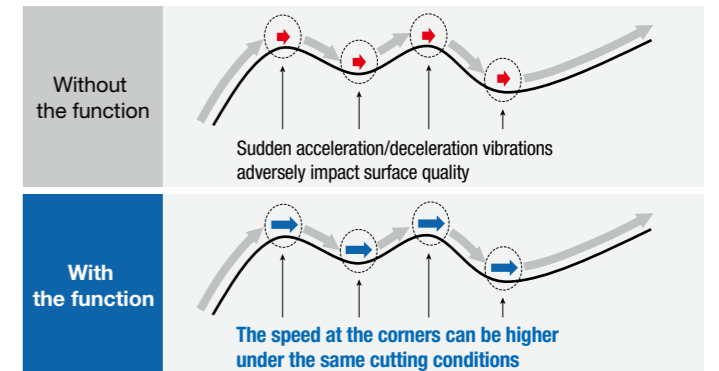

### Prevents chipping, extends tool life

**Dynamic Tool Load Control** option

When machining of difficult-to-cut material, chipping from blade runout often occurs with insert-type end mills. To stabilize such machining, solid end mills with high tool costs have generally been used. Dynamic Tool Load Control gives uniform cutting force with advanced synchronization of spindle phase and feed rate to control insert-type end mill chipping. This improves tool life and stabilizes machining. Switching from expensive solid tools also leads to reduced tool costs.

[Actual data]  
Chip volume per tool under the same cutting conditions (tool life)

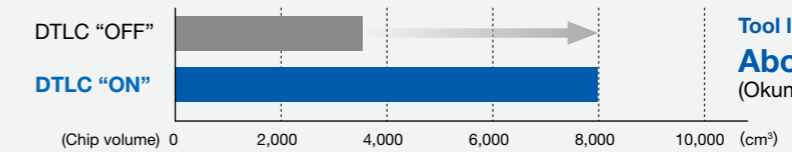

Tool life when cutting Titanium  
**About 2.3-times longer**  
(Okuma comparison)

#### Runout of insert-tipped end mill

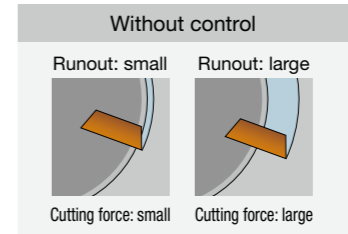
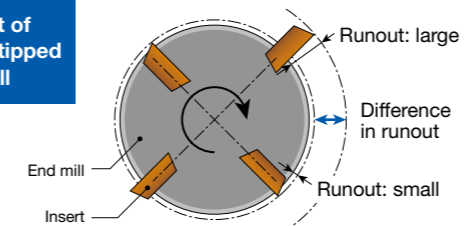

Note: The "actual data" referred to above for this brochure represent examples, and may not be obtained due to differences in specifications, tooling, cutting and other conditions.

Machine Specifications

			MB-46V II <MB-46VEII>		MB-56V II	
			No. 40	No. 50	No. 40	No. 50
Travel	X-axis (ram saddle R/L)	mm (in)	560 <762> (22.05 <30.00>)		1,050 (41.34)	
	Y-axis (table B/F)	mm (in)	460 (18.11)		560 (22.05)	
	Z-axis (spindle U/D)	mm (in)	460 (18.11)		460 (18.11)	
	Table top to spindle nose	mm (in)	150 to 610 (5.91 to 24.02)		150 to 610 (5.91 to 24.02)	
Table	Table size	mm (in)	760×460 <1,000×460> (29.92×18.11 <39.37×18.11>)		1,300×560 (51.18×22.05)	
	Floor to table top	mm (in)	800 (31.50)		800 (31.50)	
	Max load capacity	kg (lb)	500 <700> (1,100 <1,540>)		900 (1,980)	
Spindle	Speed	min <sup>-1</sup>	15,000	6,000	15,000	6,000
	Speed range		Infinitely variable		Infinitely variable	
	Tapered bore		7/24 taper No. 40	7/24 taper No. 50	7/24 taper No. 40	7/24 taper No. 50
	Bearing dia	mm (in)	ø70 (ø2.76)	ø90 (ø3.54)	ø70 (ø2.76)	ø90 (ø3.54)
Feed rate	Rapid traverse	m/min (ipm)	X-Y: 42 (1,654), Z: 36 (1,417)		X-Y: 42 (1,654), Z: 36 (1,417)	
	Cutting feed rate	mm/min (ipm)	X-Y-Z: 32,000 (1,260)		X-Y-Z: 32,000 (1,260)	
Motor	Spindle (10 min/cont)	kW (hp)	22/18.5 (30/25)	11/7.5 (15/10)	22/18.5 (30/25)	11/7.5 (15/10)
	Feed axes	kW (hp)	X-Y: 3.5 (4.7), Z: 4.6 (6.1)		X-Y: 3.5 (4.7), Z: 4.6 (6.1)	
Auto tool changer (ATC)	Tool shank		MAS BT40	MAS BT50	MAS BT40	MAS BT50
	Pull stud		MAS2		MAS2	
	Tool capacity	tool	20		20	
	Max tool dia (w/adjacent tool)	mm (in)	ø90 (ø3.54)	ø100 (ø3.94)	ø90 (ø3.54)	ø100 (ø3.94)
	Max tool dia (w/o adjacent tool)	mm (in)	ø125 (ø4.92)	ø152 (ø5.98)	ø125 (ø4.92)	ø152 (ø5.98)
	Max tool length	mm (in)	300 (11.81)		300 (11.81)	
	Max tool mass	kg (lb)	8 (18)	12 (26)	8 (18)	12 (26)
	Max tool moment	N-m (ft-lbf)	7.8 (5.7) (8 kg×100 mm (17.6 lb×3.94 in))	15.3 (11.3) (12 kg×130 mm (26.4 lb×5.12 in))	7.8 (5.7) (8 kg×100 mm (17.6 lb×3.94 in))	15.3 (11.3) (12 kg×130 mm (26.4 lb×5.12 in))
	Tool selection		Memory random		Memory random	
Machine size	Height	mm (in)	2,746 (108.11)		2,746 (108.11)	
	Floor space	mm (in)	1,950×2,810 <2,210×2,810> (76.77×110.63 <87.01×110.63>)	2,000×2,810 <2,210×2,810> (78.74×110.63 <87.01×110.63>)	2,520×3,123 (99.21×122.95)	
	Mass	kg (lb)	7,300 <7,500> (16,060 <16,500>)	7,550 <7,750> (16,610 <17,050>)	8,700 (19,140)	8,900 (19,580)
CNC		OSP-P500M		OSP-P500M		

< >: E (extension) type

## Standard Specifications & Accessories

No. 40 spindle speed	50 to 15,000 min <sup>-1</sup>	7/24 taper No. 40, 22/18.5 kW (10 min/cont), bearing dia ø70 mm
No. 50 spindle speed	50 to 6,000 min <sup>-1</sup>	7/24 taper No. 50, 11/7.5 kW (10 min/cont), bearing dia ø90 mm
Rapid traverse; X-Y, Z:	42, 36 m/min	
Spindle/spindlehead cooler		Oil temperature controller
Air cleaner (filter)		Regulator included
Spindle oil-air lubricator		
Centralized lubricant automatic oil supplier		Ball-screw, guideway, magazine
TAS-S (Thermo Active Stabilizer—Spindle)		
TAS-C (Thermo Active Stabilizer—Construction)		
ATC tool capacity		20 tools
ATC magazine shutter		Electric type
Tool unclamp package		
Coolant system*1		MB-46V II and MB-46VEII: Tank 190 L (effective 100 L), pump motor 250 W (50/60 Hz) MB-56V II: Tank 230 L (effective 120 L), pump motor 250 W (50/60 Hz)
Coolant nozzles		Flexible, 5
In-machine chip discharge (coil)		Table L/R
Chip pan*2		MB-46V II: Effective 60 L MB-56V II: Effective 69 L
Cleaning of the Y-axis slideway cover		
ATC air blower (blast)		
Chip air blower (blast)		Nozzles
Foundation washers (with jack bolts)		8 pcs
3-lamp status indicator		Type C (LED signal tower)
Work lamp*2		LED lamps (mounted on the right side) (mounted on the right and left sides for MB-46VEII and MB-56V II*2)
Full enclosure shielding		With ceiling
Two interlocking doors		MB-56V II only
Tapered bore cleaning bar		
Tool release lever		
Hand tools		
Tool box		
CNC		OSP-P500M
Color LCD operation panel		15-inch
Pulse handle		

- \*1. Use water-based coolant. For oil-based applications when necessary, larger pumps may be required.  
Highly flammable oil-based coolant require strict fire prevention measures; machine operation should be closely monitored and attended by qualified machinist or operator.  
\*2. "Required" optional specs

## Optional Specifications & Accessories

Spindle speed		
No. 40 high-power spindle 50 to 8,000 min <sup>-1</sup> △		7/24 taper No. 40, HSK-A63, 11/7.5 kW (10 min/cont), bearing dia ø70 mm
No. 40 high-speed spindle 50 to 20,000 min <sup>-1</sup> △		HSK-A63, 7/24 taper No. 40 (BIG-PLUS®), 30/22 kW (10 min/cont), bearing dia ø70 mm
No. 40 high-speed spindle 50 to 30,000 min <sup>-1</sup> △		HSK-F63, 15/11 kW (10 min/cont), bearing dia ø60 mm
No. 40 high-speed spindle 35,000 min <sup>-1</sup> △		HSK-F63, 15 kW (cont), bearing dia ø60 mm
No. 50 wide-range spindle 50 to 12,000 min <sup>-1</sup> △		7/24 taper No. 50, 26/18.5 kW (10 min/cont), bearing dia ø90 mm
No. 50 high-power spindle 50 to 12,000 min <sup>-1</sup> △		7/24 taper No. 50, 33/26 kW (10 min/cont), bearing dia ø90 mm
Dual contact spindle*1 △		HSK, BIG-PLUS®
Recommended die/mold specs		Die/mold & find-feed specs AbsoScale detection X-Y-Z axes Hyper-Surface II 0.1 μm control DNC-DT (recommended)
Tool unclamp hydraulic unit*2 △		Separately mounted
ATC magazine capacity △		32 tools (48 tools for MB-46VEII [No. 40 spindle] and MB-56V II [No. 40 spindle or No. 50 spindle]): chain magazine, 64 tools or more: matrix magazine
Tool shank		
8,000 min <sup>-1</sup> , 15,000 min <sup>-1</sup> , 20,000 min <sup>-1</sup>		CAT No. 40, DIN No. 40, HSK-A63
30,000 min <sup>-1</sup> , 35,000 min <sup>-1</sup>		HSK-F63
12,000 min <sup>-1</sup>		CAT No. 50, DIN No. 50
Pull stud △		No. 40 MAS1, JIS, CAT, DIN No. 50 MAS1, CAT, DIN
Attachment preparations		Accelerator attachment Angle-head attachment Oil-hole supplier
AbsoScale detection		X-Y-Z axes, X-Y axes
Die/mold & find-feed specs △		X-Y-Z axes rapids: 20 m/min
NC rotary table		Specify chuck, tailstock requirements, rotary table type
Index table		
Auto pallet changer (APC)		2-pallet parallel shuttle (mounted on the right side), compatible with MB-46VEII and MB-56V II. Tapped and T-slot pallets available.
High crossrail (+200 mm)		Required with APCs.
Thru-spindle coolant*3 △		1.5 or 7.0 MPa
Suction of excess coolant in spindle		Can be selected for thru-spindle coolant specs.
Chip air blower (adapter)		Not available with thru-spindle coolant specs
Oil mist unit		
Mist collector		
Semi-dry machining		
Shower coolant systems		Mounted on the ceiling or the left side, 5 nozzles
Workpiece wash gun		
In-machine chip discharge (chip washer type) △		Table L/R
Off-machine chip discharge (lift-up chip conveyor) △		Hinge type, scraper type, hinge + scraper type
Chip bucket for above △		
Sludgeless Tank		
Tool breakage detection / Auto tool length compensation		Touch sensor*4 (Metrol)
Auto zero offset / Auto gauging		Touch probe (Renishaw, Marposs)
Chemical anchors		
Sub-tables		
Work lamp		LED, added to left side
Automatic door		
Hydraulic and pneumatic fixture preps		

- △: Corresponding standard specification is deleted.  
\*1. Be sure to select this specification when BIG-PLUS® holder is used.  
\*2. Recommended for short and repetitive tool changes. For details, please contact your Okuma sales representative.  
\*3. Okuma pull studs required. (excluding HSK shanks)  
\*4. Table mounted; which may limit available working range.

## Chip discharge

### Coolant supply system

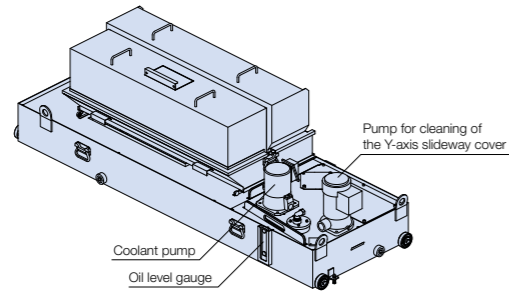

### In-machine chip discharge



Coil type chip conveyor

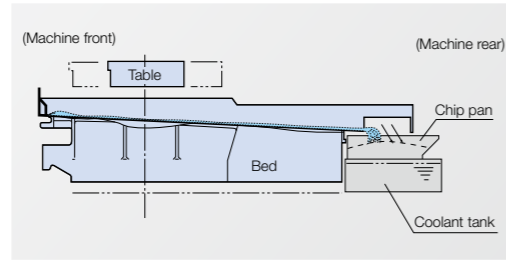

Chip flusher type (option)

### Off-machine chip discharge



Hinge lift-up chip conveyor (option)



Sludgeless Tank (option)

## Recommended Chip Conveyors (Please contact an Okuma sales representative for details.)

○: Recommended △: Conditionally recommended

Workpiece material		Steel	Cast iron	Aluminum / Nonferrous	Mixed (general use)
Chip shape					
In-machine	Coil (standard)	○	○ (Dry-Wet)	—	○
	Chip flusher (option)	—	○ (Wet)	○	—
Off-machine (option)	Hinge + scraper with drum filter	○	○	○	○
	Hinge type	○	—	—	△*1
	Scraper type	—	○ (Dry)	—	—
	Scraper type with drum filter	—	○ (Wet) with magnet	△*2	—

\*1. When there are few fine chips \*2. When chips are shorter than 100 mm

## Off-machine lift-up chip conveyors

Type	Hinge + scraper with drum filter	Hinge	Scraper	Scraper with drum filter
Shape				

Note: The machine may need to be raised (platform) depending on the type of chip conveyor. Becomes hinge + scraper (with drum filter) if Sludgeless Tank (option) is selected.

## The spindle lineup (MB-46V II / MB-46VEII / MB-56V II)

### No. 40 (standard spindle)

No. 40 15,000 min<sup>-1</sup> spindle  
Max output 22/18.5 kW (10 min/cont)  
Max torque 199/146 N-m (5 min/cont)

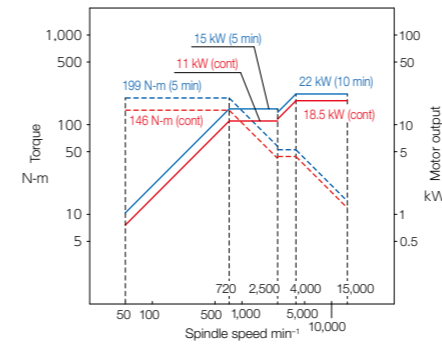

### High-power spindle (option)

No. 40 8,000 min<sup>-1</sup> spindle  
Max output 11/7.5 kW (10 min/cont)  
Max torque 198/135 N-m (5 min/cont)

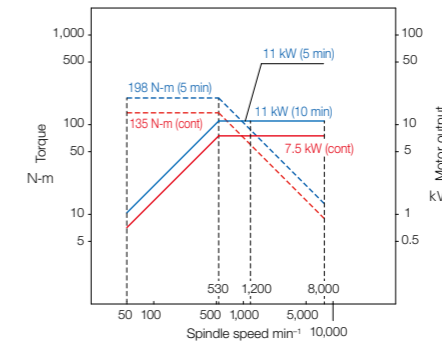

### High-speed spindle (option)

No. 40 20,000 min<sup>-1</sup> spindle  
Max output 30/22 kW (10 min/cont)  
Max torque 83/54 N-m (5 min/cont)

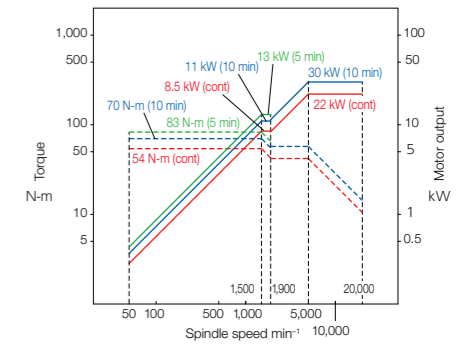

### High-speed spindle (option)

HSK-F63 30,000 min<sup>-1</sup> spindle  
Max output 15/11 kW (10 min/cont)  
Max torque 29.1/20 N-m (10 min/cont)

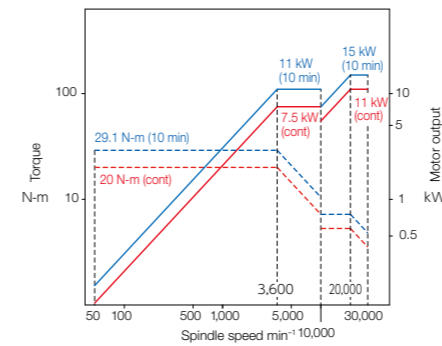

### High-speed spindle (option)

HSK-F63 35,000 min<sup>-1</sup> spindle  
Max output 15 kW (cont)  
Max torque 4.09 N-m (cont)

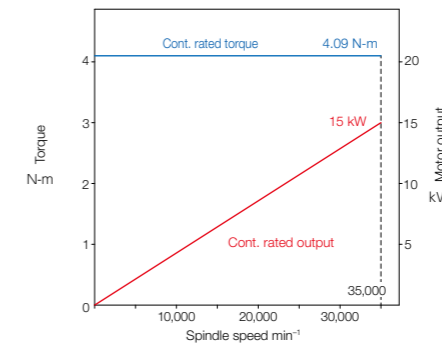

### No. 50 (standard spindle)

No. 50 6,000 min<sup>-1</sup> spindle  
Max output 11/7.5 kW (10 min/cont)  
Max torque 198/135 N-m (5 min/cont)

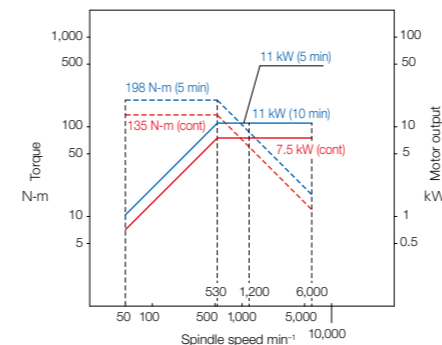

### Wide-range spindle (option)

No. 50 12,000 min<sup>-1</sup> spindle  
Max output 26/18.5 kW (10 min/cont)  
Max torque 199/146 N-m (5 min/cont)

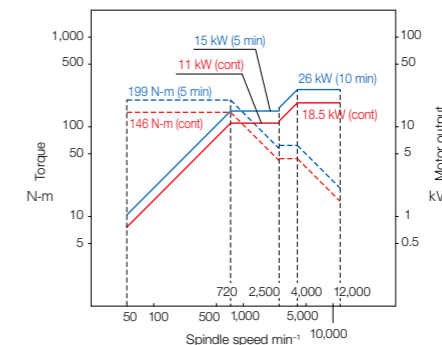

### High-power spindle [roller bearing specifications] (option)

No. 50 12,000 min<sup>-1</sup> spindle  
Max output 33/26 kW (10 min/cont)  
Max torque 302/148 N-m (10%ED/cont)

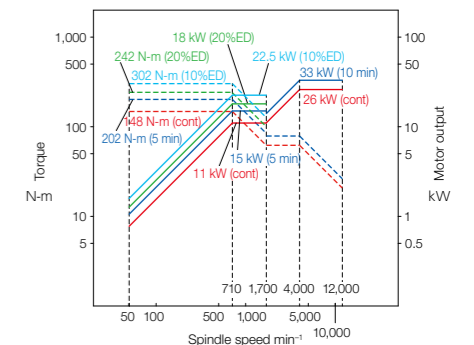

Standard Specifications

Basic Specs	Control	X, Y, Z, simultaneous 3-axis, spindle control (1 axis)
	Position feedback	OSP full range absolute position feedback (zero point return not required)
	Coordinate functions	Work coordinate system (20 sets)
	Min / Max command	±99999.999 mm, ±9999.9999° 8-digit decimal, command units: 0.001 mm, 0.01 mm, 1 mm, 0.0001°, 0.001°, 1°
	Feed override	Cutting feed override 0 to 200%, rapid traverse override 0 to 100%
	Spindle override	Override 30 to 300%,
	Tool information management	Compensation, life management, shape data, etc. are collectively managed for each tool (999 tools can be registered)
	Tool compensation	Tool length compensation / tool radius compensation 3 sets for each of the registered tools (up to 999 tools), maximum number of total sets: 999
	Operation panel	15-inch operation panel (15-inch XGA screen + multi-touch panel operations), operation panel tilt adjustment, Portable pulse handle (type A), keyboard QWERTY layout, window operation that is optimal on machine shops
	Security	Operator authentication, lock screen, OSP-VPSII-STD
Machining programming	Program capacity	Program storage: 4 GB, operation buffer: 2 MB
	Programming	Program editing, file name index display, scheduled programs, hole drilling fixed cycles (drill, deep bore drill, high-speed deep bore drill cycles, etc.), combined use of mm/min, keyway cycle, coordinate calculation, Area machining, coordinate change (shift, rotation and copying of the workpiece coordinate), block skip (1 set), User Task (GOTO statement, IF statement, arithmetic operations, IF/THEN, DO/WHILE, GOTO (variables) statement, etc., Functional operations, logic statements, inverse trigonometric functions, common variables (Std: 200 sets), local variables, System variables, sub-programs, G-/M-code macros (G-code: 20 sets, M-code: 20 sets), READ/WRITE/GET/PUT), Basic interpolation, circular radius designate, taper angle designate, NCYL command, home position, Program operation type (A-Operation, B-Operation, S-Operation), oriented spindle stop, programming help
Operations	OSP suite	Various "suite" apps support the series of machining operations, and "suite operation" enables one-touch access to those apps
	Easy Operation	"Single-mode operation" to complete a series of operations, "Setup data" to set the zero point easily using the measuring function (option)
	Operations	Manual cutting feed, sequence return, sequence number search, manual interrupt & auto return, MDI input, Pulse handle overlap, library programs, parameter I/O, relative actual position display, PLC monitor, operation help, Alarm help, continued operation at the time of temporary power failure
Monitoring, Adaptive control		Real 2D display, load meter display, maintenance monitor, collection of log data for maintenance, SERVONAVI AP, SERVONAVI SF, rotary axis notch filter switch, local variables display, display of remaining machining time
MacMan plus		Aggregation and display of machining records, operating records, operating history and trouble information, Visualization of power consumption, Records, output of records and trouble info file
Automation/Unattended operation		Auto power shutoff
Communications/Networks		USB3.0 interface (2 ports), Ethernet interface, DNC-T1, Smart I/F (Connect Plan interface), browser
High-Speed/High-Accuracy Functions		Hi-G control, Hi-Cut Pro, pitch error compensation, TAS-S (Thermo Active Stabilizer–Spindle), TAS-C (Thermo Active Stabilizer–Construction), cycle time reduction (operation time reduction, machining time reduction, easy parameter setting), in-position check, exact stop check, variable lost motion compensation
Energy-saving functions	ECO suite plus	ECO Idling Stop, ECO Operation, oil temperature controller auto control, ECO Power Monitor*
	Power Regeneration System	Regenerative power is used when the spindle and feed axes decelerate to reduce energy waste

\* The displayed power is an approximate value. If you need an accurate power value, please select the option to attach a wattmeter.

Kit Specifications

		NML		OT-IGF		Digital Twin				Digital Twin OT-IGF				
		E	D	E	D	E	D	VE	VD	E	D	VE	VD	
Interactive functions	Advanced One-Touch IGF-M (including real 3-D simulation)			●	●					●	●	●	●	
	Interactive MAP (I-MAP)					●	●	●	●					
	Smart OSP operation Machining process chart preparation and operation, setup process chart operation			●	●	●	●	●	●	●	●	●	●	
High-Speed/High-Accuracy Functions	Dynamic displacement compensation	●	●	●	●	●	●	●	●	●	●	●	●	
Digital Twin On Machine	Virtual Machining					●	●	●	●	●	●	●	●	
	Quick modeling					●	●	●	●	●	●	●	●	
	OPC UA for Machine Tools					●	●	●	●	●	●	●	●	
	OSP API KIT					●	●	●	●	●	●	●	●	
Digital Twin On PC	Virtual Machining							●	●			●	●	
	Quick modeling							●	●			●	●	
Programming Machining Operations	Operation buffer 10 MB	●	●	●	●	●	●	●	●	●	●	●	●	
	Program notes	●	●	●	●	●	●	●	●	●	●	●	●	
	Coordinate system selection (Std: 20 sets)	100 sets	●	●	●	●	●	●	●	●	●	●	●	
		200 sets		●		●		●		●		●		●
	Helical cutting (within 360°)	●	●	●	●	●	●	●	●	●	●	●	●	
	Synchronized Tapping II	●	●	●	●	●	●	●	●	●	●	●	●	
	Arbitrary angle chamfering	●	●	●	●	●	●	●	●	●	●	●	●	
	Programmable travel limits	●	●	●	●	●	●	●	●	●	●	●	●	
	Coordinate change and drawing conversion	Programmable mirror image		●		●		●		●		●		●
		Enlarge/reduce		●		●		●		●		●		●
	Sequence stop	●	●	●	●	●	●	●	●	●	●	●	●	
	Sequence return		●		●		●		●		●		●	
	Auto scheduled program update	●	●	●	●	●	●	●	●	●	●	●	●	
Tool management	Tool wear compensation	●	●	●	●	●	●	●	●	●	●	●	●	
	Tool wear compensation input restriction	●	●	●	●	●	●	●	●	●	●	●	●	
	Tool life management (including prior notice, warning, and special prior notice/warning)	●	●	●	●	●	●	●	●	●	●	●	●	
Monitoring	Real 3-D Simulation			●	●	●	●	●	●	●	●	●	●	
	Simple load monitor	●	●	●	●	●	●	●	●	●	●	●	●	
	NC operation monitor (counter, totaling)	●	●	●	●	●	●	●	●	●	●	●	●	
	Tool breakage no-load detection		●		●		●		●		●		●	
Measuring	Manual measuring (not including sensors)	●	●	●	●	●	●	●	●	●	●	●		

Notes: NML: Normal, OT-IGF: One-Touch IGF, E: Economy, D: Deluxe, VE: Virtual Economy, VD: Virtual Deluxe. For each specification, please refer to Optional Specifications in P41 and P42.

Optional Specifications

Operation panel	Monitor, operation panel	21.5-inch operation panel 21.5-inch Full HD touch screen
	Pulse handle	Portable pulse handle with function buttons (type B1) Robot-adaptable portable pulse handle with function buttons (type B2) Pulse handle with touch panel Pulse handle addition (3 pieces in total)
	Keyboard	Keyboard ABC layout
Interactive functions	Advanced One-Touch IGF-M	Auto operation decision (drilling, milling) A variety of machining including contouring, grooving, pocket machining, milling, boring and linear chamfering Realistic 3D simulated test cuts Direct from machining order tables (no G-/M-codes) Slope machining, 5-face machining
	Interactive MAP (I-MAP) Interactive MAP (I-MAP-B) Interactive MAP (I-MAP-C) Smart OSP Operation	Part programs can be edited according to guide maps (with figure calculation function) Solid shape machining function added to I-MAP pattern cycle Functions to determine cutting conditions and automatically determine drilling cycle added to I-MAP Machining process chart preparation and editing functions: By using the process chart to follow the guidance, rapid preparation for machining operations is possible even without knowing G-/M-code. Machining process chart operating functions: Direct operation from the machining order chart (no G-/M-code). Independent operation for each process or from the middle of a process is possible. Task support functions using the setup process chart: Pre-machining setup task guidance
Digital Twin	Virtual Machining	Confirmation tasks are more efficient in a virtual space. Machining trajectories, material scraping, interference checks.*1 High-speed, high-precision machining time estimation. Power consumption (carbon dioxide emissions) estimation.
	Quick modeling	Easy preparation of 3D models of tools, jigs and workpieces. Supply of affluent 3D model data. Selecting 3D models of tools allows not only virtual spaces for digital twins but also automated configuration of real space control data.
	OPC UA for Machine Tools	Communication specification for machine tools compatible with OPC UA communication Compatible with OPC UA version 1.00 (essential functions)
	OSP API KIT	API for Windows®-based application development
Programming Machining Operations	Imperial/metric switch	Program commands and data setting operations are switchable between metric and imperial.
	Operation buffer	10 MB
	Sub-program large capacity operation	When a sub-program is called and executed, the relevant sub-program is searched for and executed
	Program notes	To show notes in part program screens
	Auto scheduled program update	Updates part programs during a scheduled run
	Block skip	Use soft ON/OFF keys on screen to skip execution of a part program Block skip 9 sets
	Program branch	The branch of the part program can be turned ON/OFF with soft keys on the screen (number of sets: 9)
	Work coordinate system	Number of selected sets: 100, 200, 400
	Helical cutting	Circular interpolation + helical axis interpolation
	3D circular interpolation	Three dimensional interpolation
	Skip	Axis travel by G-code, movement skip by sensor input
	Arbitrary angle chamfering	Easy chamfering at an arbitrary corner angle (C, R)
	Synchronized Tapping II	Synchronized tapping, deep bore synchronized tapping, high-speed deep bore synchronized tapping cycle
	Cylindrical side machining	Can easily carry out machining of cylindrical side
	Tool max rotational speed setting	The rotation speed limit is set for each milling tool
	F1-digit feed	Feed speed command by designating the number - external switch type/parameter type
	Programmable travel limits	Per G22, G23
	Axis name designation	Can change axis name by G-code
	Slope machining	Type I/Type II
	Fixture offset	The workpiece coordinate of the rotary/tilting axis is offset
	Dynamic fixture offset	The workpiece coordinate is automatically offset according to the movement of the rotary axis
	Harmonic Spindle Speed Control (HSSC)	The spindle speed is periodically changed to avoid chatter during cutting
	Tool grooving	Hole machining (simultaneous XY + spindle)
	Inverse time feed	Feed rate command with cutting time
	Spindle path control	Contouring per simultaneous control of spindle C and X-Y-Z axes
	Dynamic Tool Load Control	Control of chipping due to tool runout during the machining of difficult-to-cut materials
	Punch tap cycle	High-speed threading cycle using tools dedicated to punch tap
	Coordinate change and drawing conversion	Enlarges and reduces drawings, programmable mirror image
	User Task	Common variables: 1,000 or 2,000 sets G-code macros: 100 sets (80 sets added) Input/output variables (16 points each)
	Sequence stop	Stops machining at prescribed sequence number
	Sequence return	Mid-block sequence return
	Pulse handle angle and arc feed	Angle and arc feed with simultaneous 2-axis control by pulse handle
Tool management	Tool life management	The cumulative number of machined workpieces or cumulative cutting time is calculated, and when the preset value is reached, a spare tool is automatically assigned. Life data of each tool are displayed as graphs; tool life prior notice, tool life warning, tool life special prior notice/warning
	Tool wear compensation	Compensation for the wear amount of the tool
	Tool wear compensation input restriction	Limitation on the amount of tool wear compensation
	3D tool compensation	Designates offset direction at I, J, K
	TOOL-ID (with chips)	Central management of tool data for tools with ID chips
	TOOL-ID (without chips)	Integration of tool data with tools for management and storage
	TOOL-IC	Tool management with Factory Manager manufactured by BIG DAISHOWA SEIKI

External input output Communication functions Networking	DNC connection	DNC-C/Ethernet DNC-T3 DNC-B DNC-DT	Connected to host using Ethernet I/F for MacMan-net Ethernet RS-232C for OSP; connects to host RS-232C; remote buffer operations Remote operation using Ethernet: part programs are downloaded from PCs for the machining operation
	RS-232C interface	FL-net Ethernet/IP OSP-MTConnect	RS-232C interface 1CH to 4CH Connected to host and other machines using FL-net Connected to host and other machines using Ethernet/IP MTConnect I/F for production management systems produced by other companies
Measuring	Auto tool length offset/ Auto tool breakage detection	Auto tool length offset/ Auto tool breakage detection	Automatically performs tool length compensation and tool breakage detection Continuous tool gauging: Multiple tools are continuously gauged automatically
	Auto gauging Manual measurement Interactive gauging NC Gage	Auto gauging Manual measurement Interactive gauging NC Gage	Checks workpiece dimension, and auto zero offset; Measured data output to file Easy manual tool length compensation, workpiece gauging and zero setting according to guidance on the display Easy semi-automatic tool length compensation, workpiece gauging and zero setting according to guidance on the display Workpiece dimensions and geometrical tolerance can be measured
Monitoring, Adaptive control	One-Touch Spreadsheet Collision Avoidance System (Units and actions to prevent interference are limited)	One-Touch Spreadsheet Collision Avoidance System (Units and actions to prevent interference are limited)	Excel® files assist machining setups Interference during automatic, MDI and manual operations is prevented Easy modeling of shape data Simultaneous movement with Hyper-Surface II and Tool Center Point Control II Real time simulation of all machining modes (auto, MDI, manual operation)
	Real 3-D Simulation	Real 3-D Simulation	Solid/cross section/transmission display of workpieces, tool path display, tool shape display With cycle time calculator
	Simple load monitor NC operation monitor Status indicator Tool breakage no-load detection Synchronized tapping torque monitoring MOP-TOOL AI Machine Diagnosis*2 Machine Status Logger Cutting Status Monitor	Simple load monitor NC operation monitor Status indicator Tool breakage no-load detection Synchronized tapping torque monitoring MOP-TOOL AI Machine Diagnosis*2 Machine Status Logger Cutting Status Monitor	Monitors spindle overload (machining stops when overloaded) NC hour meters for NC start, spindle rotation, cutting, etc. and 4 NC workpiece counters NC running lamp, alarm lamp, machining end lamp In drilling, detects the no-load cutting status of the spindle caused by tool breakage, triggers an alarm and stops operation During synchronized tapping, monitors for spindle overload (overload causes machining stop and evacuation) Overload monitoring and adaptive control AI-based spindle and feed axis diagnostics Commands, operations and spindle and feed axis loads are recorded to increase, analyze and improve machining traceability To reduce machining failure, spindle and feed axis loads are monitored to trigger an alarm, pause operations, and/or trigger evacuation operations.
	Machining Navi M-i Machining Navi M-gII+ Feed axis retraction Tool retract cycle Workpiece counters on machine Hour meters on machine Operation end buzzer Tapping retraction Adaptive control (AC) using external signals Tool monitoring system General purpose overload detection	Machining Navi M-i Machining Navi M-gII+ Feed axis retraction Tool retract cycle Workpiece counters on machine Hour meters on machine Operation end buzzer Tapping retraction Adaptive control (AC) using external signals Tool monitoring system General purpose overload detection	Based on chatter vibration during machining, the spindle speed is automatically optimized to stabilize machining Chatter vibration during machining is visualized to help automatically select the optimal spindle speed for stable machining Pull back in axial direction during power failures Execute shelter cycle according to interruption signal Counted with M02 and M30 or dedicated M-code The power ON time, spindle rotation time, NC running time and cutting time are counted A buzzer goes off at M02/M30 and M00/M01 and also when an alarm is generated Retract the tapping tool when a power failure occurs during tapping Interruption program function, slide hold, feed axis override activated using external signals CARON TMAC8 I/F Detect overload in external devices and display an alarm
Automation/ Unattended operation functions	Warm-up External program Connection with automated devices	Warm-up External program Connection with automated devices	Automatically turn on the power to perform warm-up at the preset time Push button, rotary switch, digital switch, BCD Robot loader I/F, stacker crane I/F, FMS link I/F
	ROID control system	STANDROID	Robot control by OSP Easy robot programming with the guidance of ROID Navi
High-Speed/ High-Accuracy functions	AbsoScale detection Dynamic displacement compensation 0.1 μm control Hyper-Surface II Inductsyn detection, DD encoder detection Straightness compensation Misalignment compensation	AbsoScale detection Dynamic displacement compensation 0.1 μm control Hyper-Surface II Inductsyn detection, DD encoder detection Straightness compensation Misalignment compensation	X-Y-Z axes Dynamic displacement during acceleration/deceleration is compensated for, to improve machining accuracy 0.1 μm command increments 3 linear axes, 3 linear axes + 2 rotary axes A-axis, B-axis, C-axis Compensation for linear axis motion Compensation for misalignment of the rotary axis rotation center
	Energy-saving functions	ECO suite plus	ECO Power Monitor (on-machine wattmeter), ECO Hydraulics, Spindle Power Peak Limiter, External output interface of consumed electricity
Other functions	Circuit breaker External M-signals OSP-VPS II-EX Monitor display language (multi-language)	Circuit breaker External M-signals OSP-VPS II-EX Monitor display language (multi-language)	Power shutoff with the detection of earth leakage [4 sets, 8 sets] Signals for controlling external devices such as rotary indexing tables Allowlist-based virus protection system Language switchable

\*1. If the Collision Avoidance System specs are enabled, then interference checks can be performed for structural components of the machine in addition to workpiece, tools, and fixtures.  
\*2. With AbsoScale detection specs, ball-screw wear detection is possible.  
Note: Cannot be selected for some machine specifications.

**Table size** The dimensions in [ ] refer to those for the E (extension) type. (MB-46VEII)

Unit: mm

■ MB-46V II

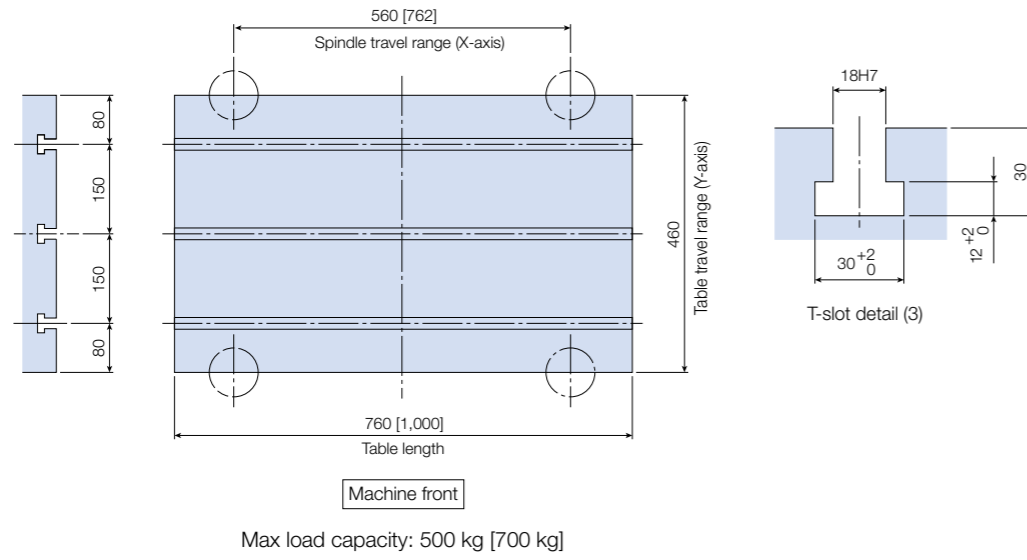

**Table size**

Unit: mm

■ MB-56V II

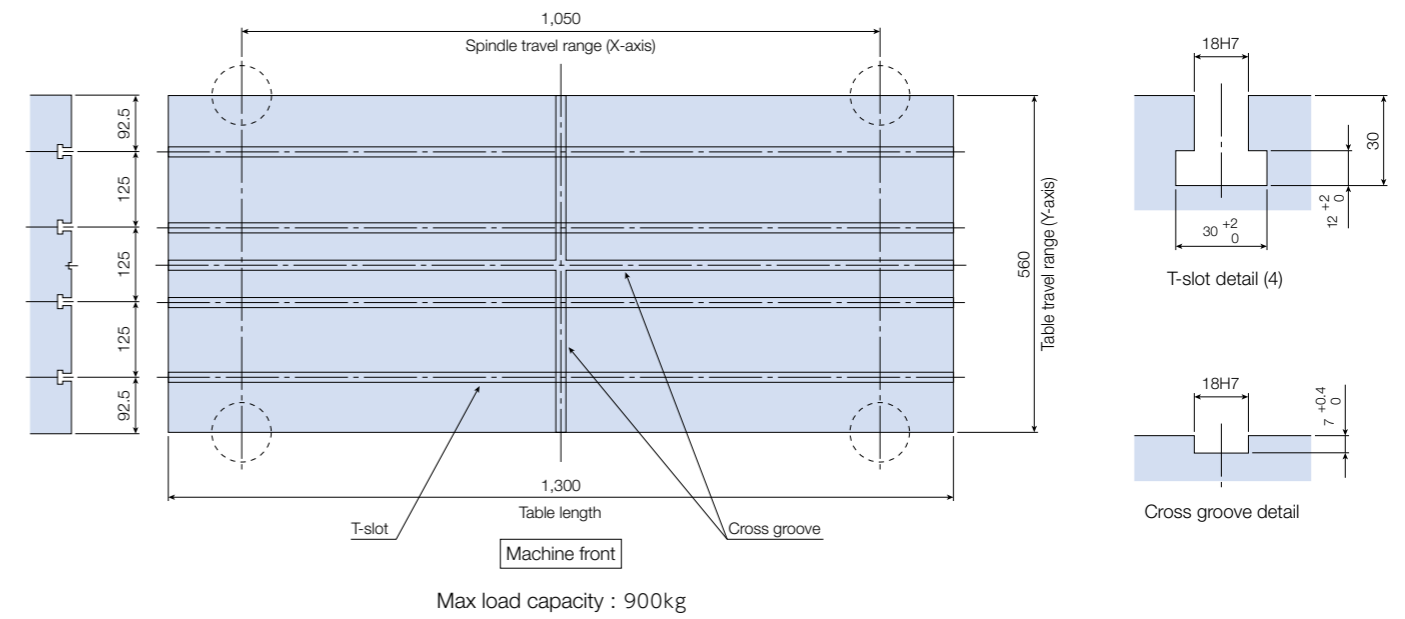

**Working ranges** The dimensions in [ ] refer to those for the E (extension) type. (MB-46VEII)  
The dimensions in < > refer to those for high-crossrail specs  
The dimensions in { } refer to those for APC specs (\* refers to the case of T-slot pallets)

Unit: mm

■ MB-46V II

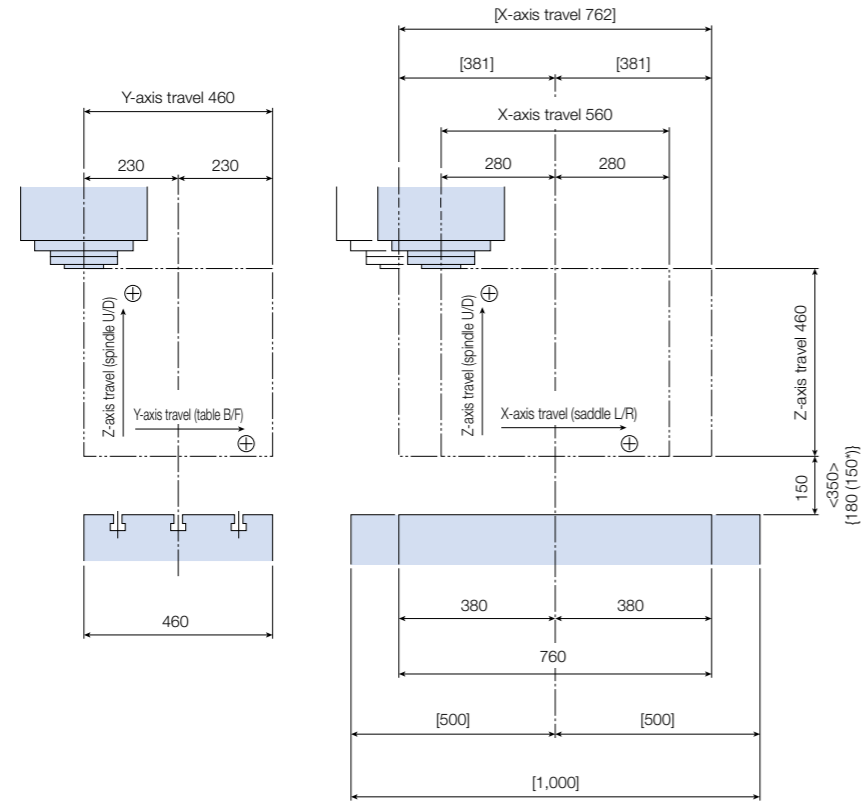

Note: The drawings are different for APC specs.

**Working ranges** The dimensions in < > refer to those for high-crossrail specs  
The dimensions in { } refer to those for APC specs (\* refers to the case of T-slot pallets)

Unit: mm

■ MB-56V II

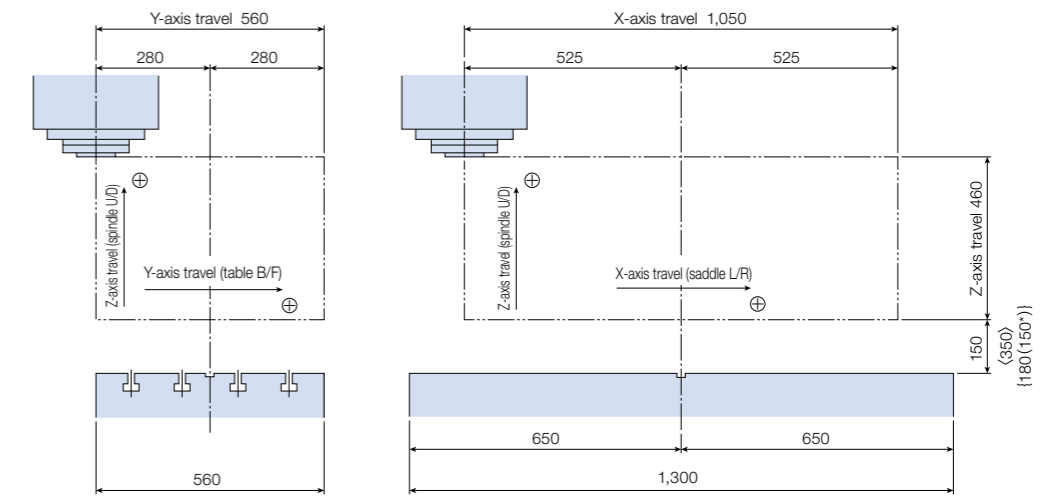

Note: The drawings are different for APC specs.

■ MB-46V II

(Dimensions for MB-46V II (No. 40), [MB-46VEII], <MB-46V II (No. 50)>)

Power inlet  
 23 KVA □60 mm<sup>2</sup> 4C (8,000 min<sup>-1</sup>, 6,000 min<sup>-1</sup>)  
 37 KVA □60 mm<sup>2</sup> 4C (12,000 min<sup>-1</sup> (26 kW), 15,000 min<sup>-1</sup>)  
 47 KVA □60 mm<sup>2</sup> 4C (12,000 min<sup>-1</sup> (33 kW))  
 41 KVA □60 mm<sup>2</sup> 4C (20,000 min<sup>-1</sup>)  
 27 KVA □60 mm<sup>2</sup> 4C (30,000 min<sup>-1</sup>)  
 33 KVA □60 mm<sup>2</sup> 4C (35,000 min<sup>-1</sup>)  
 Height from floor: 710 mm or 2,310 mm

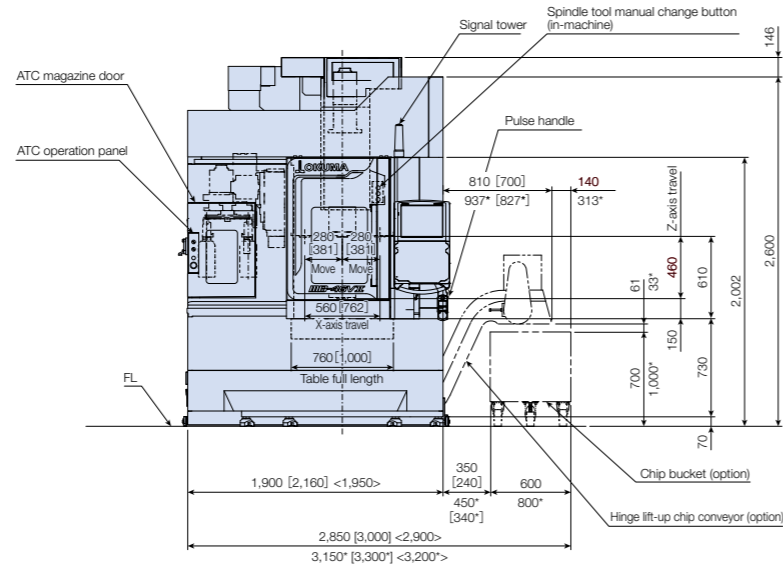
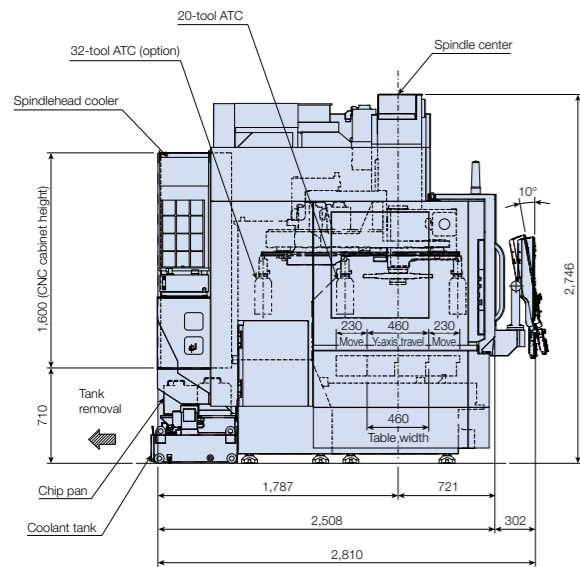
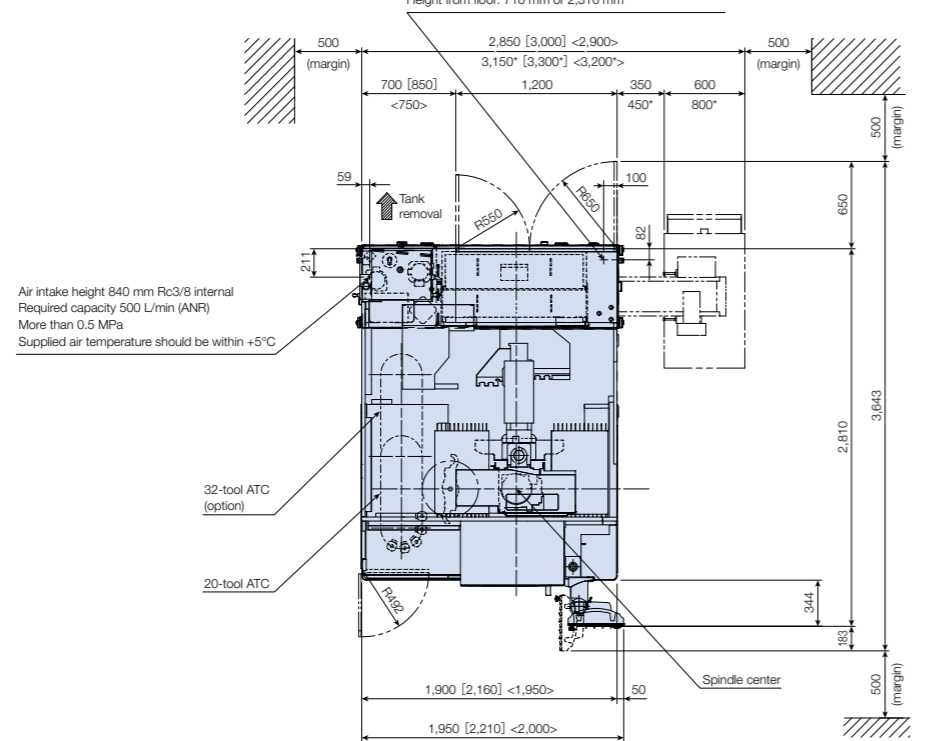

Lift-up chip conveyor .... Height: 750 mm  
 \* Height: 1,000 mm

Note: The drawings are different for high-crossrail specs and APC specs.

■ MB-56V II

(Dimensions for MB-56V II (No. 50))

Power inlet  
 23 KVA □60 mm<sup>2</sup> 4C (8,000 min<sup>-1</sup>, 6,000 min<sup>-1</sup>)  
 37 KVA □60 mm<sup>2</sup> 4C (12,000 min<sup>-1</sup> (26 kW), 15,000 min<sup>-1</sup>)  
 47 KVA □60 mm<sup>2</sup> 4C (12,000 min<sup>-1</sup> (33 kW))  
 41 KVA □60 mm<sup>2</sup> 4C (20,000 min<sup>-1</sup>)  
 27 KVA □60 mm<sup>2</sup> 4C (30,000 min<sup>-1</sup>)  
 33 KVA □60 mm<sup>2</sup> 4C (35,000 min<sup>-1</sup>)  
 Height from floor: 710 mm or 2,310 mm

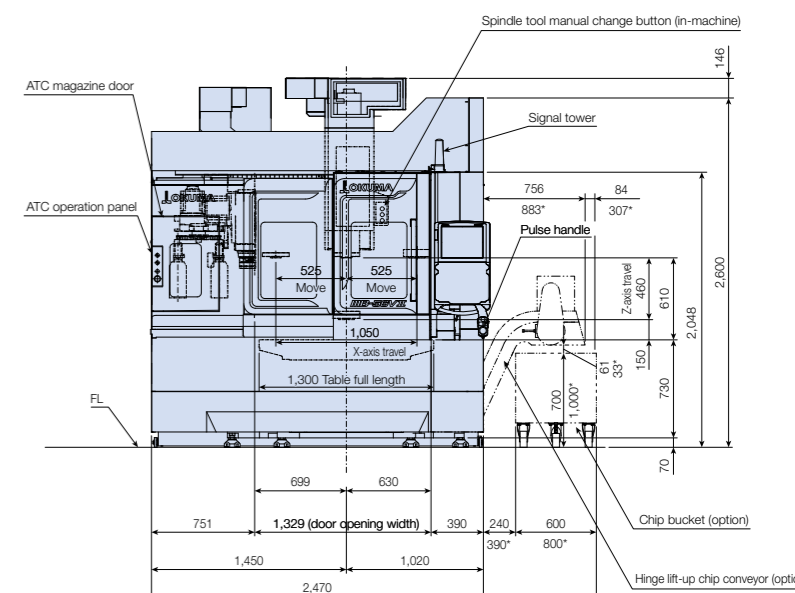
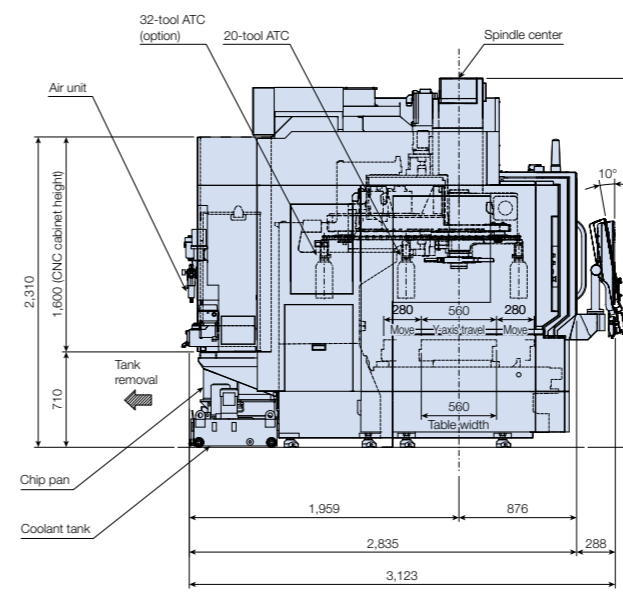
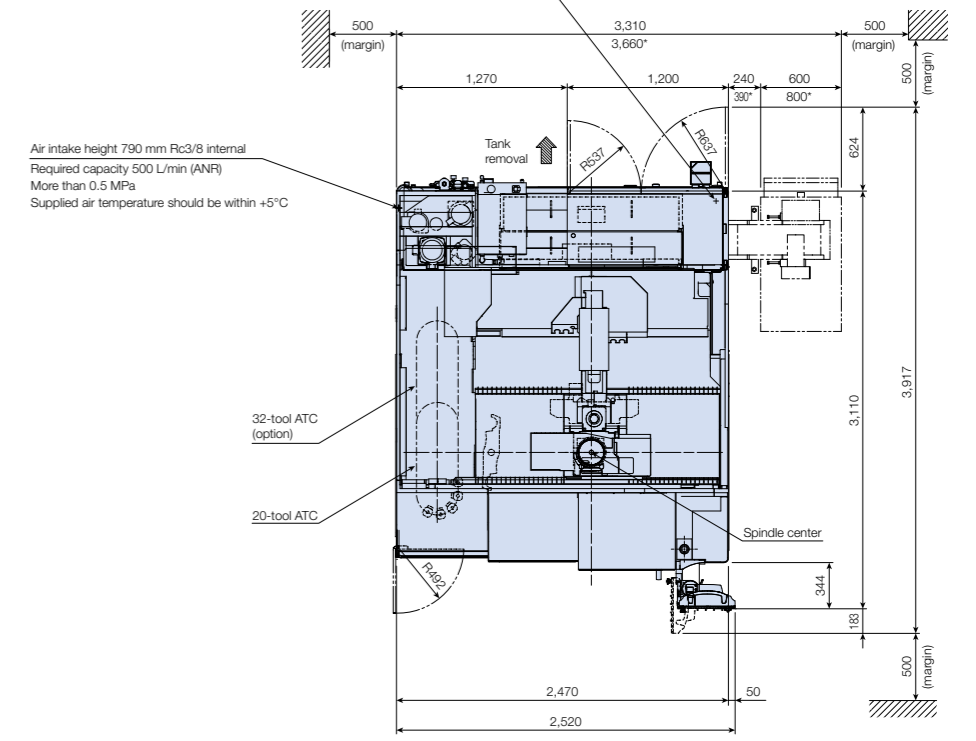

Lift-up chip conveyor .... Height: 750 mm  
 \* Height: 1,000 mm

Note: The drawings are different for high-crossrail specs and APC specs.

When using Okuma products, always read the safety precautions mentioned in the instruction manual and attached to the product.

●The specifications, illustrations, and descriptions in this brochure vary in different markets and are subject to change without notice.  
Pub.No.MB-V2-E-(4a)-400(May2024)D

This product is subject to the Japanese government Foreign Exchange and Foreign Trade Control Act with regard to security controlled items; whereby Okuma Corporation should be notified prior to its shipment to another country.



**OKUMA Corporation**

Oguchi-cho, Niwa-gun,  
Aichi 480-0193, Japan  
TEL: +81-587-95-7825 FAX: +81-587-95-6074