

***MCR-S*** (Super)

High-Speed, High-Quality  
Double-Column Machining Center  
[5-Face Machining]

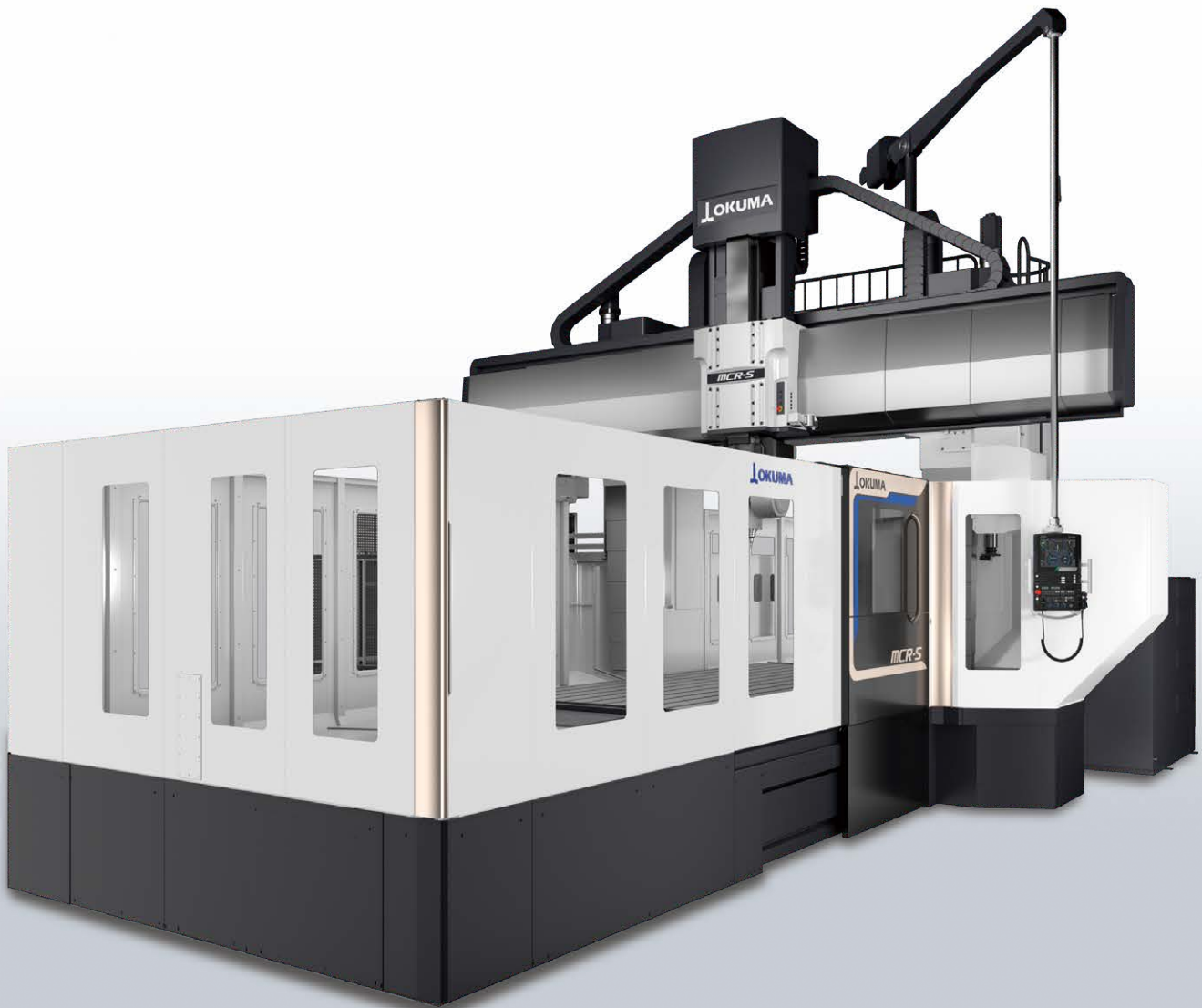

# MCR-S (Super)

High-Speed, High-Quality  
Double-Column Machining Center  
[5-Face Machining]

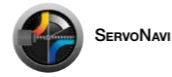

## The productivity revolution for press die manufacturing. How to amaze your polishing and die matching meister with superb machined surface quality

The MCR-S (Super) is a high-speed, high-quality double-column machining center that faithfully reproduces the sharp edges and smooth, beautiful curves that designers insist on.

By constantly striving to provide solutions for higher speed, accuracy, and surface quality, Okuma delivers what's required of a machine for advanced die/mold applications.

Geometric accuracy, machined surface quality, and feed rates have evolved to new dimensions with higher finishing accuracy, which drastically reduces post-process work by "saving operators the time and trouble" of polishing surfaces and assuring upper/lower die alignments.

Heavy-duty cutting is also possible due to excellent machine rigidity for roughing to finishing done completely on one machine, resulting in considerably reduced lead times — a significant advantage for truly efficient die/mold manufacturing.

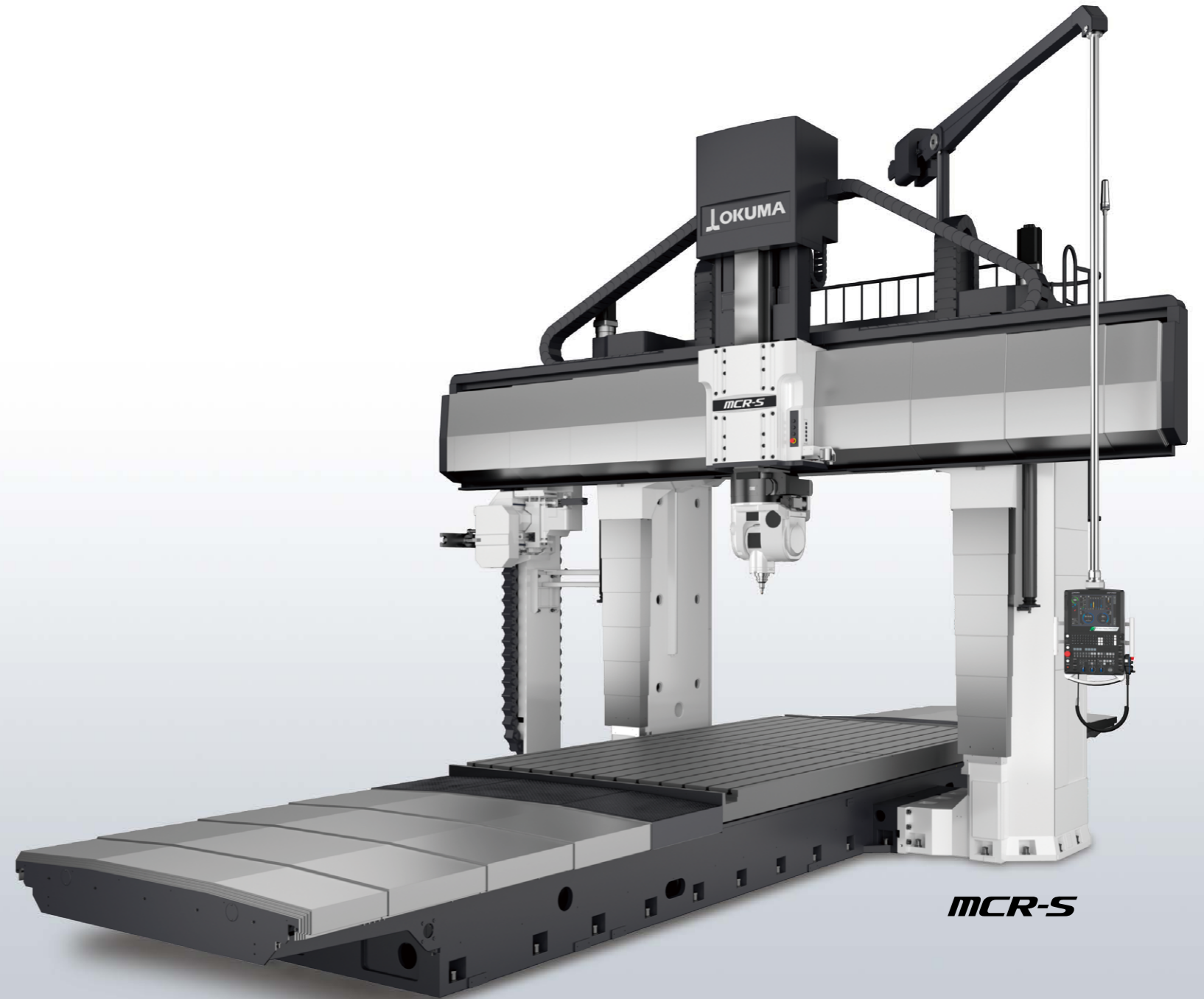

**MCR-S**

Photographs and images used in this brochure may include optional equipment.  
Not showing full-enclosure shielding and other items.



## The designer strove for the best industrial design possible to achieve high-quality surfaces with superb accuracy at fast cutting speeds.

The key die/mold issues include improving cycle times, accuracy, area level errors, and surface quality — at high speeds and quality levels that would satisfy any customer. Production lead times can become considerably shorter while improving finishing accuracies at the same time.

### Significant reduction in production lead time Machine structural design achieves fastest-class continuous feed rates

While maintaining high shape accuracy and machined surface quality, cycle times were reduced by 25% at best-class fast continuous feeds. In addition, the MCR-S enables highly efficient heavy-duty cutting of large press dies.

### Advanced, high surface quality technology dramatically reduces polishing work

Streak-free machined surfaces that minimize polishing provided by Okuma Machine & Control mechatronics.

Okuma's Hyper-SurfaceII NC technology automatically compensates for "disturbances" found in part programs that can lead to defective machined surfaces. In addition, the acquired highly accurate and rigid designs have been fortified to achieve even higher surface quality at higher finishing speeds.

### High-accuracy engineering drastically reduces hand finishing times in die alignments

The further evolvement of our Thermo-Friendly Concept also minimizes step errors between machined surface areas that occur during long runs. In addition, cutting edge position measuring by the swivel laser sensor helps keep machined area step errors cut by tools with different indexing angles to 10 μm or less.

The number of upper/lower die alignments has been greatly reduced.

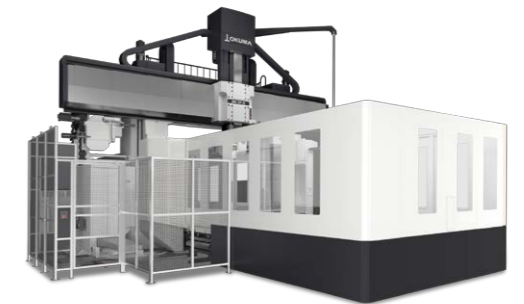

X-axis travel (table front/back)	mm	4,200 to 6,700
Y-axis travel (spindlehead L/R)	mm	3,200, 3,700
Z-axis travel (ram up/down)	mm	800
W-axis travel (crossrail up/down)	mm	1,000, 1,200
Effective width between columns	mm	2,650, 3,150
Speed range	min <sup>-1</sup>	30 to 10,000
Rapid traverse	m/min	X: 30, Y: 32*, Z: 15
Table size	mm	2,000 × 4,000 to 2,500 × 6,500
Table maximum load	kg	22,000 to 43,000

\* Deceleration near both ends of Y-axis travel

# Significant reduction in production lead time Machine structural design achieves fastest-class continuous feed rates

Cycle times: **25% shorter\***

Previous model: 7 h 13 min



**MCR-S: 5 h 25 min**

(Body designed surface only)

\* Compared to previous model automobile side panel operations



High speed continuous feed while maintaining high  
shape accuracy and machined surface quality

Average continuous cutting feed: X-, Y-axis: **Max 20 m/min**  
Z-axis: **Max 10 m/min**

## Machine designed high-speed continuous feed

Shortening cycle times while maintaining geometric accuracy with optimal cooling.  
Mechanically designed to ensure minimal following error even at fast feeds.

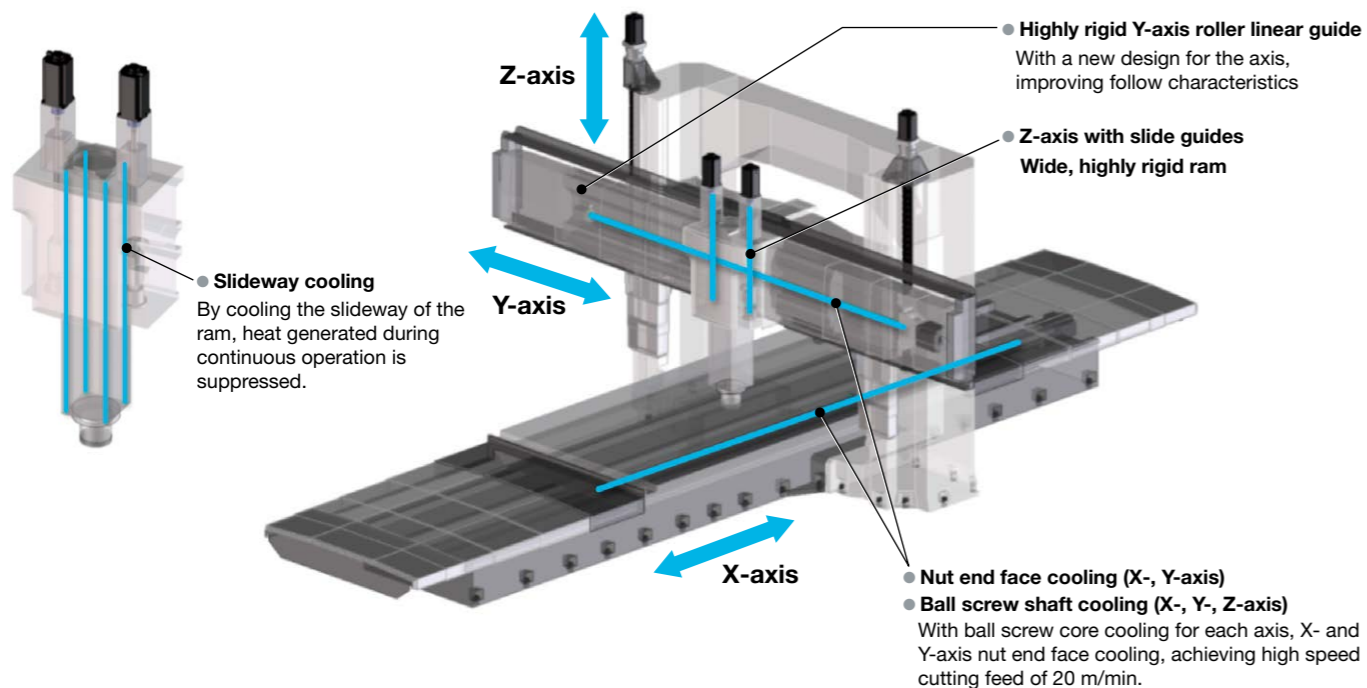

## Everything from roughing to finishing is completed with one machine

Cycle time is shortened for heavy-duty cutting with a powerful spindle.

By completing roughing to finishing with one machine, the operator time for changing setups is greatly reduced.

### Powerful spindle enables heavy-duty cutting

- Cutting capacity: **710 cm<sup>3</sup>/min**  
(Material: S45C  
Z-axis 800 mm extension; machining in all directions)
- Max spindle output: 26 kW
- Max spindle torque: 735 N-m

### High-rigidity ram type spindlehead

- Ram size: □ 350 mm

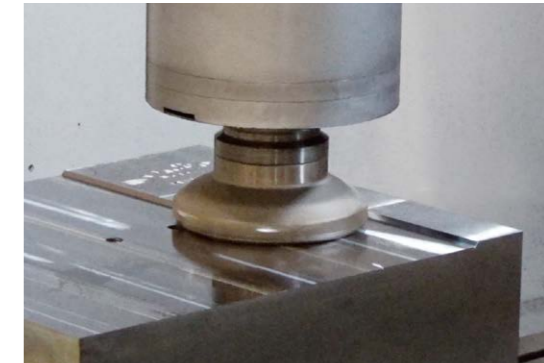

### Spindle torque/power diagrams

#### Standard spindle

- Spindle speed ..... 10,000 min<sup>-1</sup>
- Max output ..... 26/22 kW (30 min/cont)
- Max torque ..... 735/622 N-m (30 min/cont)

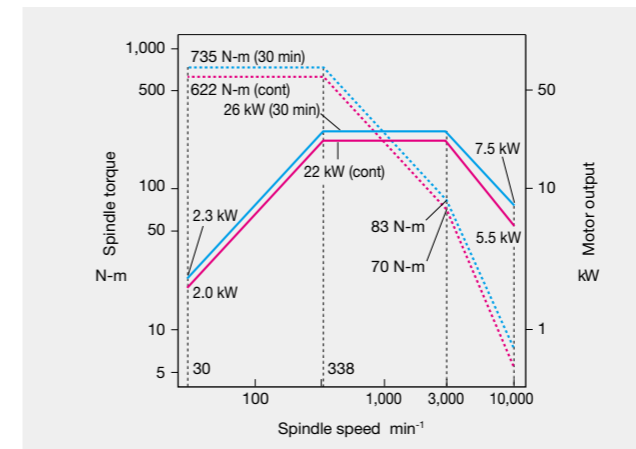

#### Aluminum applications (option)

- Spindle speed ..... 10,000 min<sup>-1</sup>
- Max output ..... 30/22 kW (30 min/cont)
- Max torque ..... 305/247 N-m (30 min/cont)

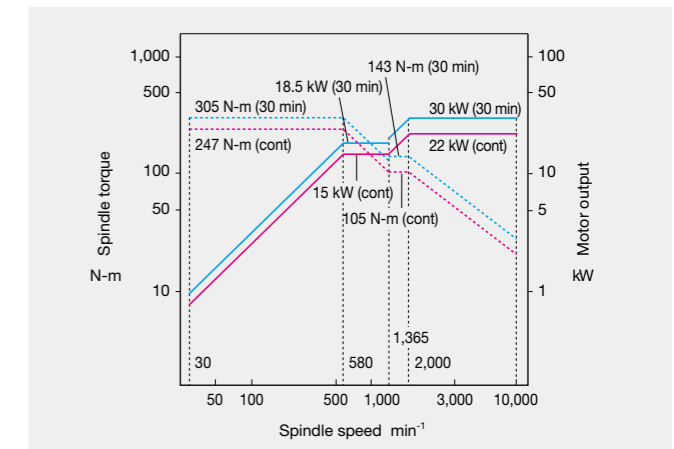

# Advanced, high surface quality technology dramatically reduces polishing work

## Reduction of hand finishing time

### Hyper-SurfaceII

#### Improving the performance of machining dies and free-form surfaces

There is no need to modify machining data. Ridgelines and uneven surface edges are reduced, the machined surface quality is improved, and hand-polishing time is eliminated.

Hyper-SurfaceII automatically compensates for fluctuations in the CAM machining data, and for positional misalignment between edges and adjacent cutter paths, while maintaining the required shape accuracy. In addition, SMART finishing suppresses vibration without reducing the speed at the corners, reduces the cycle time and improves the surface quality.

\* Please contact us for 5-axis specifications.

\* The effect varies depending on the machining shape.

#### Smooths minor fluctuations and variations in command points

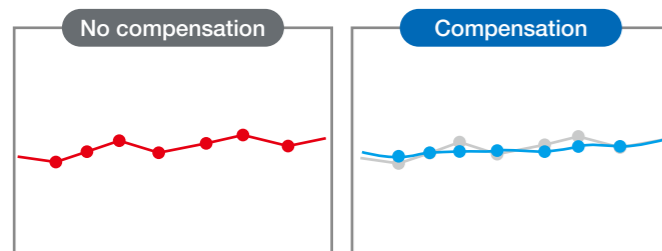

#### Equalizes the corner passing speed for each path

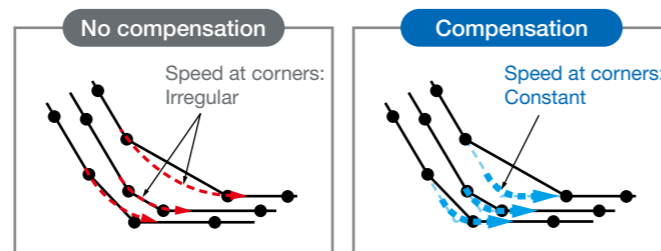

#### Adjust steps errors between adjacent cutter paths

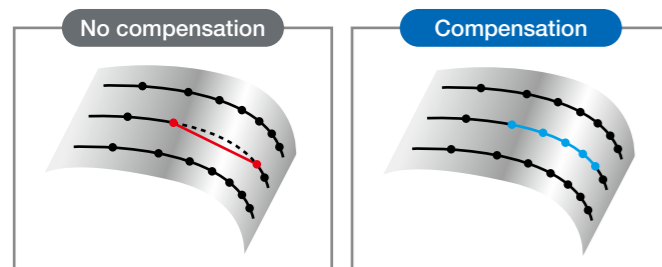

#### Reproducing edge lines between sides

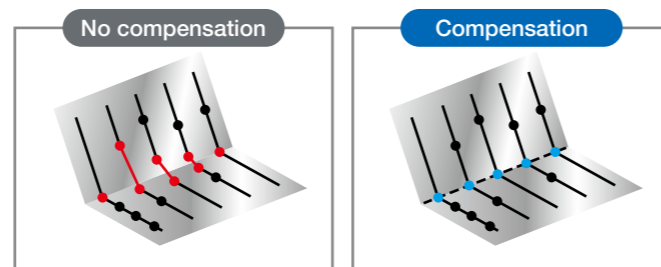

#### Comparison of machined surface quality

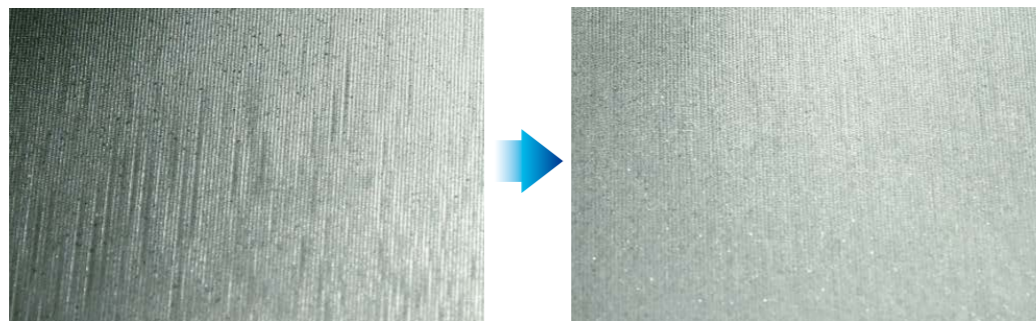

Hyper-SurfaceII  
No compensation

Hyper-SurfaceII  
Compensation

# High-accuracy engineering drastically reduces hand finishing times in die alignments

## Area step errors $10 \mu\text{m}$ or less Machine designed to achieve high geometric accuracies

### Enhanced Thermo-Friendly Concept



Without column cooling (as before), the new machine design further adjusts the thermal balance of the column, etc by suppressing Z-axis tilt that occurs with ambient temperature change — even better than ever.

Even with long periods of operation, it is possible to reduce the step height errors caused by corner cuts to reduce the time required for hand finishing.

#### Z-axis tilt due to ambient temperature change

$1.7 \mu\text{m}/200 \text{mm}$  (actual data)\* Ambient temperature change:  $8^\circ\text{C}$  in the X-axis direction

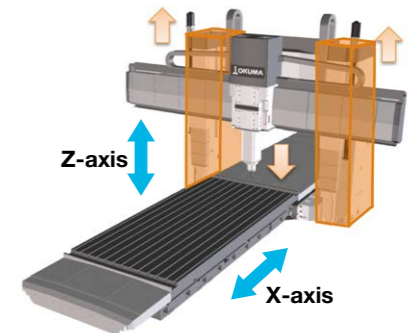
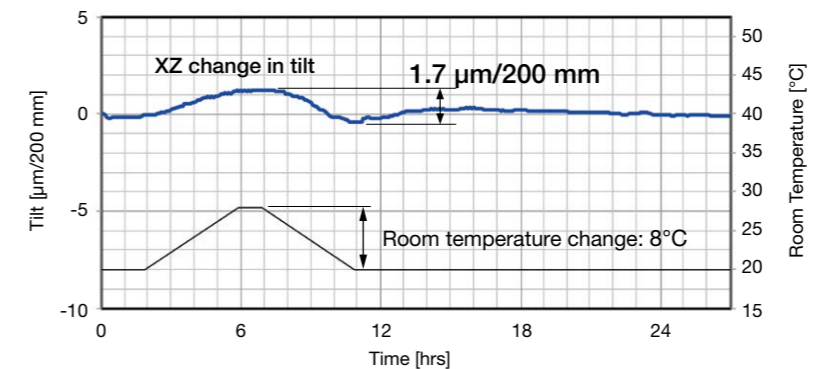

\* Calculated from measurement displacement at the height of 500 mm

### The swivel type laser sensor is mounted behind the table near the cutting point (option)

Measurement of tool length with the swivel type laser sensor eliminates cutting edge position error caused by differences in indexing angle and rotation speed of the tool, to minimize area step errors.



The swivel type laser sensor is mounted behind the table near the cutting point. Since the measuring device also turns with the indexing of the attachment head measurement of the cutting edge position is done while in the machining area.

# High accuracy is enabled in normal factory environments



## Eliminate waste with the Thermo-Friendly Concept

Okuma's Thermo-Friendly Concept achieves high dimensional stability not only when the room temperature changes, but also at machine startups or when machining is resumed. The warm-up operation time to stabilize thermal deformation is shortened, and the burden of dimensional correction when resuming machining is reduced.

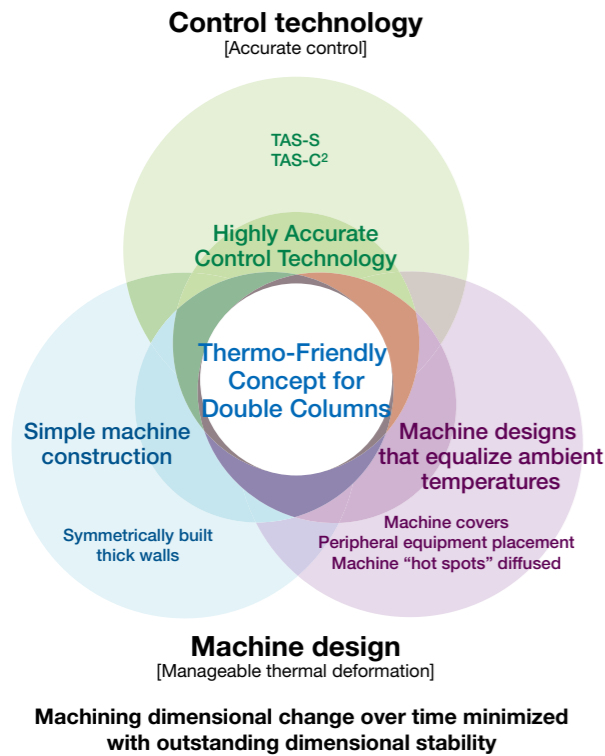
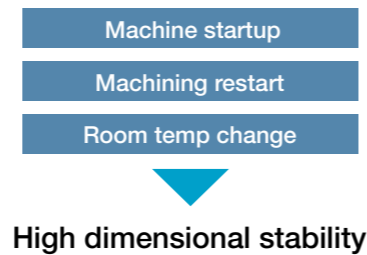

- 1 Minimal temperature deviation
- 2 Manageable thermal deformation
- 3 Accurate compensation

## Integrated machine design and control technology

The Thermo-Friendly Concept plays a principal role in our machine design. With simple machine designs and construction that equalize ambient temperatures, deformation is predictable, and complex torsion or tilting is controlled. Highly accurate compensation technology with the OSP controller developed by Okuma accurately controls thermal

deformation from room temperature changes, spindle thermal deformation from frequently changing spindle speeds, and inconsistent thermal deformation from coolant temperature. With the Thermo-Friendly Concept (Manageable Deformation – Accurately Controlled), Okuma products provide unrivaled dimensional stability.

## Sophisticated thermal displacement control technology

	Thermo-Friendly Premium Specifications
Spindle thermal deformation control technology	Thermo Active Stabilizer – Spindle (TAS-S)
Environmental thermal deformation control technology	Thermo Active Stabilizer – Construction for large machines (TAS-C²) TAS-C²: Thermo Active Stabilizer – Table Thermo Active Stabilizer – Construction

## Thermo Active Stabilizer – Spindle (TAS-S)

Thermal deformation of the spindle from high spindle speeds is accurately controlled (X-Y-Z axes). Accurate control is also performed in cases of frequent spindle speed changes, and thermal deformation of attachment heads are also controlled.

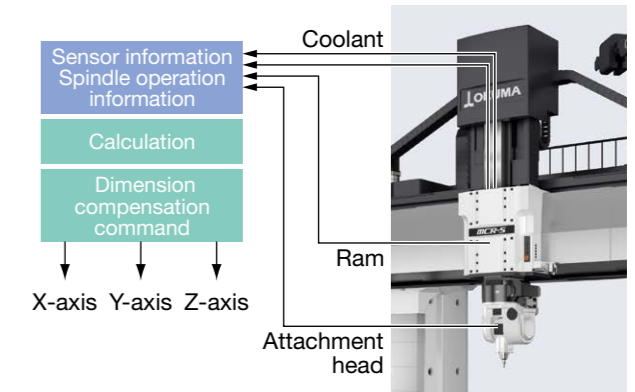

## Thermo Active Stabilizer – Construction for large machines (TAS-C²)

The machine (construction) is optimally controlled to maintain the required machining accuracies even when ambient temperatures change. In addition, it is possible to control dimensional changes due to thermal expansion of the table and obtain stable dimensional accuracy even for large workpieces.

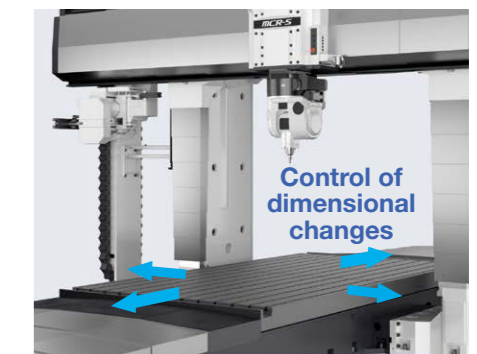

# Highly accurate, productive and eco-friendly



Okuma has worked to reduce energy consumption in order to achieve carbon neutrality at the three factories in Japan which are our main production bases.

We have realized high productivity through automation and process-intensive machining, in addition to high-accuracy machining, and we then introduced the use of green energy to transform the three domestic factories into carbon-neutral factories.

“Green-Smart Machines” is our definition of Okuma’s intelligent machine tools, which autonomously achieve stable dimensional accuracy and reduced energy consumption, to support environmentally friendly production. Our policy is to deploy “Green-Smart Machines” fully, to help achieve a carbon-free society.

Starting with products manufactured at those carbon-neutral factories and distributing them globally, we will partner with our customers to address the social challenges faced by the manufacturing industry.

## Green-Smart Machines are environmentally friendly

products that autonomously achieve stable dimensional accuracies and reduced energy consumption.

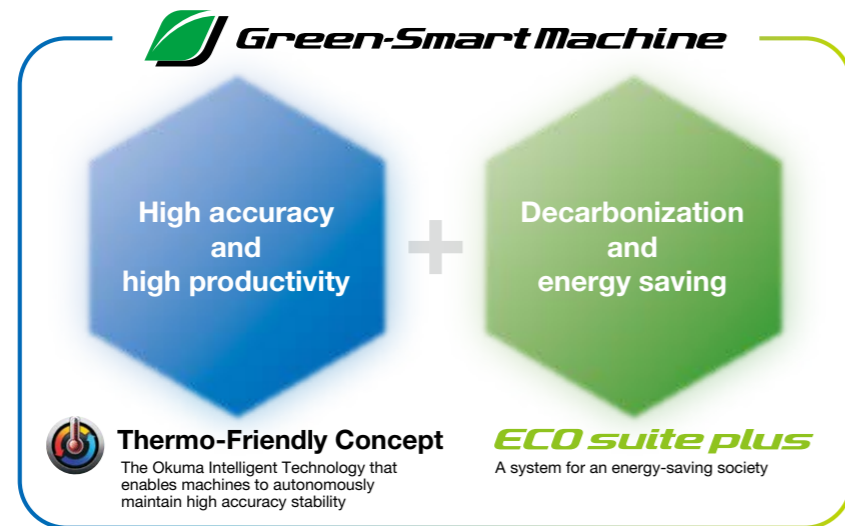

## Thermo-Friendly Concept

The Okuma Intelligent Technology that enables machines to autonomously maintain high accuracy stability

The unique concept of accepting temperature changes achieves consistent high accuracy without special coolers or excessive air conditioning.

### Reduction of warm-ups and dimensional compensation

Reduce the time needed for daily warm-ups and dimensional compensation to adjust to ambient temperature changes.

### Reduction of power used for air conditioning

Maintain high stability of dimensional accuracy even if the air conditioning temperature range is expanded.

### Reduction of machine body coolers

Achieve outstanding dimensional accuracy without any special machine body cooling being required to maintain accuracy.

### The Okuma way to cool

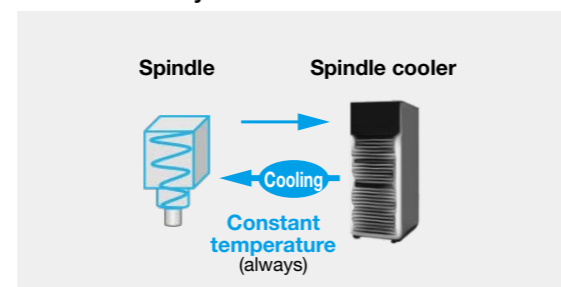

By always setting a constant coolant supply temperature, the cooler power consumption is reduced.

# ECO suite plus A system for an energy-saving society

## ECO Idling Stop

Accuracy ensured, cooler off

All auxiliary equipment when not needed (most of factory power consumption), can be turned off. The cooling system necessary for maintaining accuracy uses Thermo-Friendly Concept technology, and the machine itself decides when to cool and stop idling while maintaining high accuracy.

With ECO suite plus, the machine automatically detects the operating status, eliminating the need to push buttons while reducing carbon dioxide emission as much as possible without operator awareness.

The machine monitors the cooling level when not machining, and proactively turns off the cooler while maintaining high accuracy conditions.

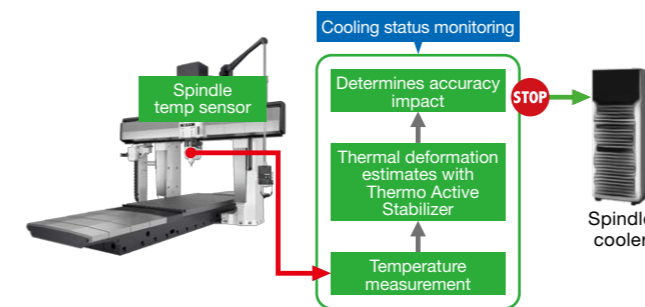

## ECO Operation

Peripheral equipment runs only when needed

By using only the required peripherals (chip conveyor, mist collector), energy-saving operations that also maintain high productivity are possible. ECO suite plus enables more detailed tuning of “operation patterns” to thoroughly reduce carbon dioxide emission.

ECO PARAMETER	ECO IDLE STOP (1/4)	ECO OPERATION
ECO IDLE STOP ELAPSED TIME	0000:00	REMAINING TIME UNTIL ECO IDLE STOP READY 12:46
Chip conveyor interval control	PARAMETER	UNIT
Chip conveyor interval:active time	OFF	
Chip conveyor interval:suspended time	100	[min]
	200	[min]

## ECO Power Monitor

Confirming energy savings and analyzing reductions

Power is shown individually for spindle, feed axes, and auxiliaries on the OSP operation screen. In addition to regenerative power, the energy-saving benefits from auxiliary equipment stopped with ECO Idling Stop can be confirmed on the spot.

[On-the-spot checks of operating status, power consumption, and carbon dioxide emissions]

Three phases of visualization (view, record, and analyze) and energy-saving functions, which make it possible to analyze even the operating status of each device, support the decarbonization cycle.

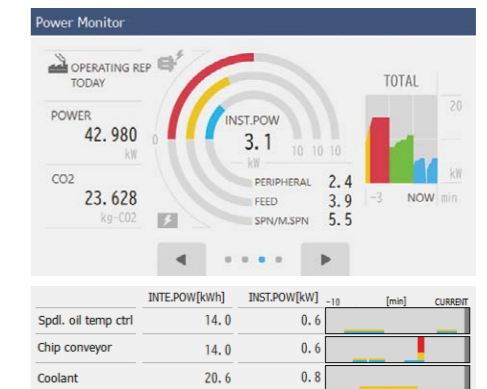

[Analyze carbon dioxide emissions and improve machine tool operation]

With ECO suite plus, detailed data analysis of carbon dioxide emissions for each device is possible on a PC.

[Example of auxiliary power display using One-Touch Spreadsheet (option)]



Note: The spreadsheet file for data analysis needs to be prepared by the customer.

# Okuma Intelligent Technology exhibits powerful effect on machine shop floors

## 3D Smart Calibration System (option) Calibrating the volumetric accuracy of the machine

### Any operator can easily calibrate machine accuracy

Factory floor surface deformation over the long term affects machine accuracy.

The 3D Smart Calibration System checks and calibrates the machine accuracy (positioning, straightness, perpendicularity) by automatically measuring the accuracy master (the absolute accuracy reference) using an easy-to-operate touch probe.

By calibrating accuracy at the right time, high accuracy is maintained throughout the machining space over the long term.

Notes: The machine accuracy that can be calibrated differs depending on the machine specifications and type of accuracy master (option) used. The floor deformation of the customer's machine shop foundation may be large and require machine level adjustments.

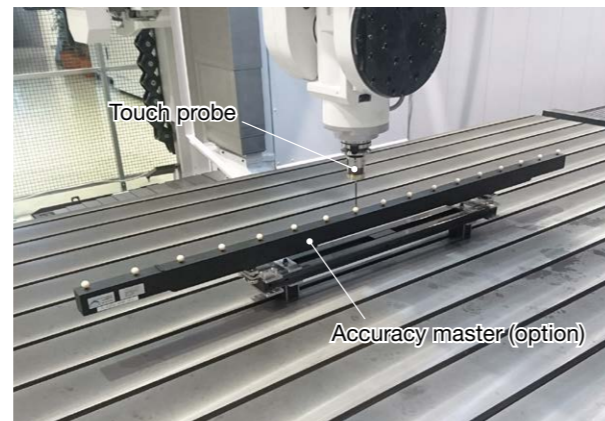

Automatic measurement of ball beam by touch probe

## Accuracy Stability Diagnosis Function (option) Self-diagnosis of changes in machine accuracy

### To diagnose mechanical thermal deformation due to non-uniform factory temperatures

On production floors where the machine is exposed to wind or sunlight, the temperature around the machine becomes uneven, creating an environment in which the thermal deformation of the machine tends to increase.

The Accuracy Stability Diagnosis Function estimates the change in machine accuracy due to non-uniform factory temperatures, quantifies it as "accuracy stability" and displays that information on the screen.

If the accuracy is unstable, the operator will be notified by a message or alarm. More stable machining accuracy can be achieved by performing accuracy checks and adjustments when notified.

### Diagnosing changes in machine accuracy from factory floor thermal deformation

The change in machine accuracy due to thermal deformation of the production floor is also estimated and quantified as a factor of "accuracy stability". Notifications of the best timing for machine accuracy adjustments with 3D Calibration etc, will be provided.



## Auto Attachment Head Compensation (option) Anyone can perform rotation compensation of attachment heads easily

### Rotation compensation that used to take half day to a full day now done automatically in twenty minutes\*

Auto Attachment Head Compensation is a function that is automatically sets attachment head rotation compensation values. It is quick, easy and can be used by anyone. By setting the compensation values, the program commands can be made for tool tip position even with different attachment head type and rotation tilt. Creation of NC programs and machine operation becomes much easier.

Auto Attachment Head Compensation performs this rotation compensation work automatically, enabling automatic setting in 20 minutes\* for a task that used to take an experienced operator a half to full day with three attachment heads. High machining accuracy can also be maintained with regular measurements.

\* The time needed for automatic settings differs with the attachment head.



The datum sphere is fixed to the table and measurement preparations are completed by simply positioning the attachment head with attached touch probe near the top of the datum sphere.

Note: AAHC requires Okuma's auto gauging and auto zero offset functions (with touch probe).

## SERVO NAVI Optimized Servo Control

Achieves long term accuracy and surface quality

### SERVO NAVI AP (Automatic Parameter setting)

#### Work Weight Auto Setting

Cycle time shortened with faster acceleration

On table travel type machining centers, the table feed acceleration with the previous system was the same regardless of weight, such as workpieces and fixtures loaded on the table.

Work Weight Auto Setting estimates the weight of the workpiece and fixture on the table and automatically sets the linear axis servo parameters, including acceleration, to the optimum values. Cycle times are shortened with no changes to machining accuracy.

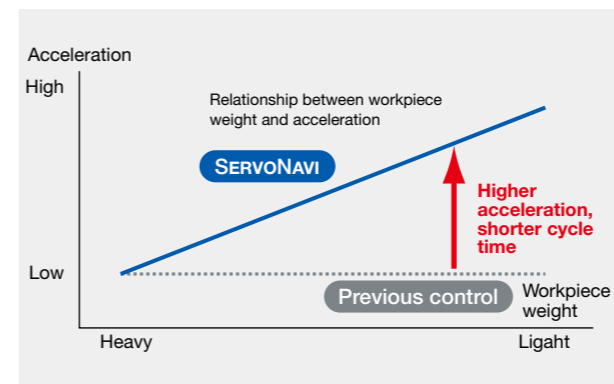

### SERVO NAVI SF (Surface Fine-tuning)

#### Reversal Spike Auto Adjustment

Maintains machining accuracy and surface quality

Slide resistance changes with length of time machine tools are utilized, and discrepancies occur with the servo parameters that were the best when the machine was first installed. This may produce crease marks at motion reversals and affect machining accuracy (part surface quality).

Reversal Spike Auto Adjustment maintains machining accuracy by switching servo parameters to the optimum values matched to changes in slide resistance.

#### Vibration Auto Adjustment

Contributes to longer machine life

When aging changes machine performance, noise, vibration, crease marks, or fish scales may appear.

Vibration Auto Adjustment can quickly eliminate noise and vibration even from machines with years of operation.

#### Deflection Auto Adjustment\*

Maintaining high quality machined surfaces on dies/molds

With fast acceleration/deceleration in the machining of dies and molds, etc, positioning error due to bending (ball screw expansion/contraction) can affect the machined surface quality.

Deflection Auto Adjustment maintains the surface quality of die/mold machined surfaces by automatically adjusting the servo parameters to match the amount of bending, even when the amount of bending of the ball screw has changed and positioning error has occurred as a result of changes over time.

\* X-Y axes AbsoScale detection specs are needed.

## Machining Navi M-gII (option) Cutting condition search for milling/machining

Longer tool life and shorter machining times by optimizing cutting conditions

### Maximizing machine tool performance

Navigates effective measures by detecting and analyzing machining chatter with a microphone attached to the machine. Effects are seen mainly on high rotation chatter with M-gII.

Machining Navi (OSP) provides the answer!

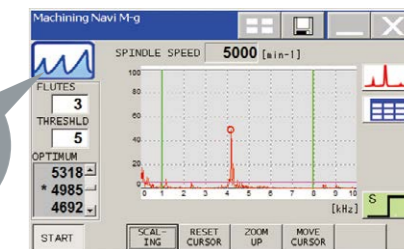

## Collision Avoidance System (option) Collision prevention

Significantly reducing setup and trial times

### "Concentrate on machining" without collision worries

NC controller (OSP) with 3D model data of machine components—workpiece, tool, fixture, attachment head— performs real time simulation just ahead of actual machine movements. In both automatic operation and manual movements, advance checks are made for interference or collisions and the machine movement is stopped.

Machinists (novice or pro) will benefit from reduced setup and trial cycle times, and the confidence to focus on making parts.

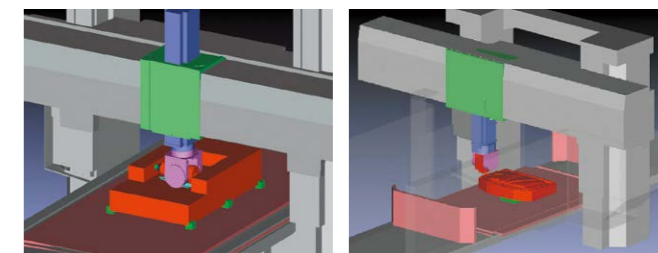

# Lineup of attachment heads suitable for advanced die making

## Abundant range of attachment heads (Built-in)

All kinds of shapes can be machined under the best conditions with the wide variety of attachment heads.

Many different processes can be performed continuously in auto operation with the auto tool changer (ATC) and auto attachment changer (AAC), greatly increasing productivity.

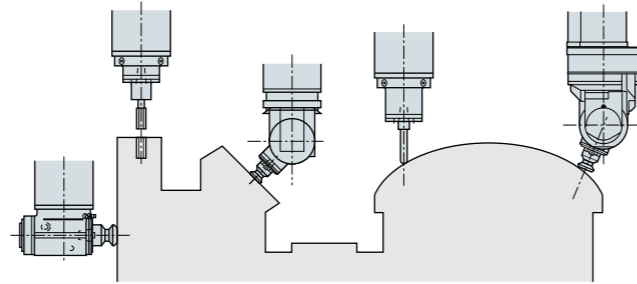

### High-speed machining

- Max spindle speed: 15,000 to 30,000 min<sup>-1</sup>
- Continuous cutting feed rate: Max X-, Y-axis: 20 m/min  
Max Z-axis: 10 m/min

### Extension head



15,000 min<sup>-1</sup> 11 kW  
20,000 min<sup>-1</sup> 15 kW

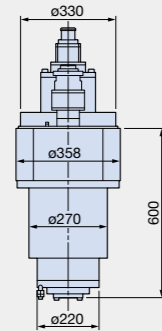

Unit: mm

### 30° angular heads



30° angle  
20,000 min<sup>-1</sup> 15 kW

30° angle  
30,000 min<sup>-1</sup> 11 kW

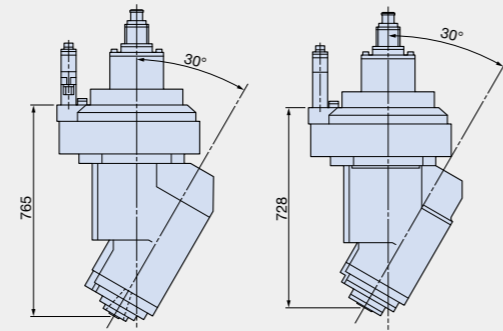

Unit: mm

### Universal index head (B-/C-axis), NC-BC Universal head



Universal index head (B-/C-axis)  
B-axis 1° C-axis 1° 20,000 min<sup>-1</sup> 15 kW

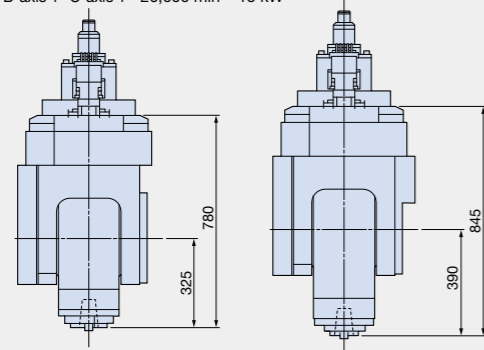

Unit: mm

NC-BC Universal head  
20,000 min<sup>-1</sup> 15 kW

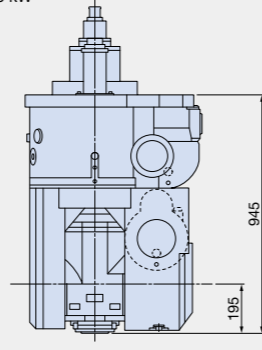

Unit: mm

# Smooth discharge of large amounts of chips

## Recommended chip conveyors (Please contact an Okuma sales representative for details.)

○: Recommended

Workpiece material		Steel, stainless steel	Cast iron	Aluminum/ non-ferrous metal	Mixed (general)	Special blank materials
Chip shape						Ceramic, carbon, glass, etc.
In-machine chip discharge	Full length gutters (std)	○	○	—	○	○
	Hinge type	○	○	○ (Aluminum)	○	—
Off-machine chip discharge	Hinge + scraper with drum filter (recommended)	○	○*	○	○	—
	Hinge type	○	—	—	○	—

\* Attachment of a magnet separator is recommended

Note: The specs recommended above are based on wet machining (including washer specifications). For dry machining, please contact our sales staff.

## Example of chip conveyor placement

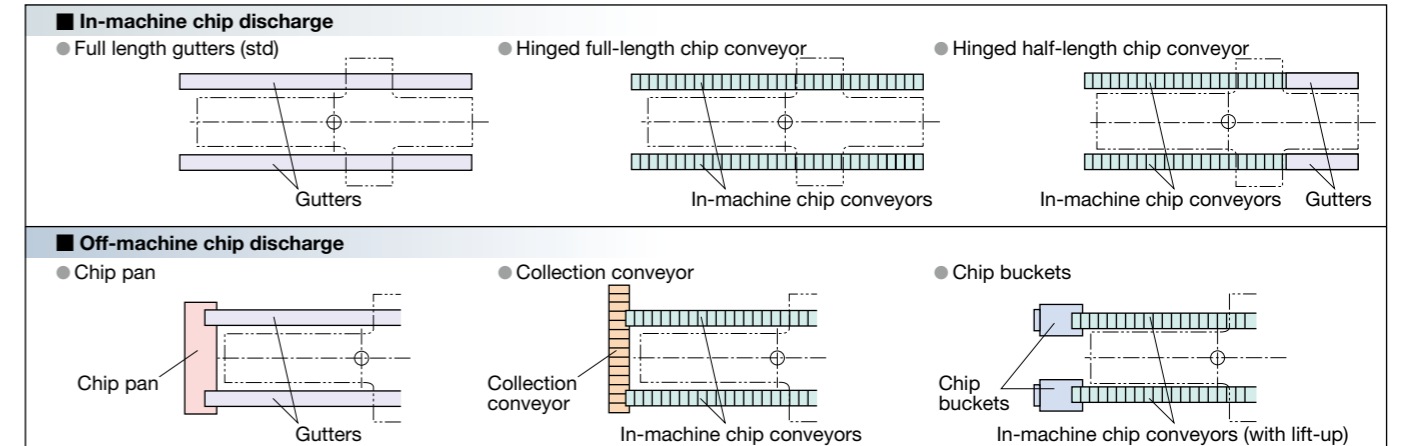

Note: Conveyor chip discharge direction (rear), off-machine chip conveyor discharge direction (operation side, magazine side), chip coolant tank position, etc. can be combined to match space. Please consult with your Okuma sales representative to confirm final arrangements.

## Collection conveyor chip discharge (lift-up conveyors)

Type	Hinge + scraper with drum filter	Hinge
Shape		

## Machine Specifications

Model		MCR-S 25			MCR-S 30		
Item		25 x 40	25 x 50	25 x 65	30 x 40	30 x 50	30 x 65
<b>Travel</b>							
X-axis (table front / back)	mm (in)	4,200 (165.35)	5,200 (204.72)	6,700 (263.78)	4,200 (165.35)	5,200 (204.72)	6,700 (263.78)
Y-axis (spindlehead left/right)	mm (in)	3,200 (125.98)			3,700 (145.67)		
Z-axis (ram up/down)	mm (in)	800 [1,000] (31.50 [39.37])					
W-axis (crossrail up/down)	mm (in)	1,000 (39.37)			1,200 (47.24)		
Effective width between columns	mm (in)	2,650 (104.33)			3,150 (124.02)		
Table to spindle nose	mm (in)	0 to 1,550 (0 to 61.02)			0 to 1,750 (0 to 68.90)		
<b>Table</b>							
Working surface	mm (in)	2,000 x 4,000 (78.74 x 157.48)	2,000 x 5,000 (78.74 x 196.85)	2,000 x 6,500 (78.74 x 255.91)	2,500 x 4,000 (98.43 x 157.48)	2,500 x 5,000 (98.43 x 196.85)	2,500 x 6,500 (98.43 x 255.91)
Maximum load	kg (lb)	22,000 (48,400)	27,000 (59,400)	34,000 (74,800)	25,000 (55,000)	33,000 (72,600)	43,000 (94,600)
T-slots	Width x No. <center pitch>	24H7 x 11 (center 200, both ends 130)			24H7 x 13 (center 200, both ends 180)		
Height from machine bottom	mm (in)	850 (33.46)			900 (35.43)		
<b>[Pallet]*1</b>							
Working surface	mm (in)	2,000 x 3,700 (78.74 x 145.67)	2,000 x 4,700 (78.74 x 185.04)	2,000 x 6,200 (78.74 x 244.09)	2,500 x 3,700 (98.43 x 145.67)	2,500 x 4,700 (98.43 x 185.04)	2,500 x 6,200 (98.43 x 244.09)
Maximum load	kg (lb)	8,000 (17,600)	10,000 (22,000)	13,000 (28,600)	10,000 (22,000)	12,000 (26,400)	15,000 (33,000)
T-slots	Width x No. <center pitch>	24H7 x 11 (center 200, both ends 130)			24H7 x 13 (center 200, both ends 180)		
Height from machine bottom	mm (in)	1,200 (47.24)			1,250 (49.21)		
<b>Spindle (Extension head)</b>							
Speed range	min <sup>-1</sup>	30 to 10,000					
Taper bore		7/24 taper No. 50					
Bearing diameter	mm (in)	ø85 (3.35)					
<b>Feed rate</b>							
Rapid traverse	m/min (fpm)	X: 30, Y: 32 <sup>2</sup> , Z: 15 (X: 98, Y: 105 <sup>2</sup> , Z: 49)					
Cutting feed rate	m/min (fpm)	X: 20, Y: 20, Z: 15 (X: 66, Y: 66, Z: 49)					
Average continuous feedrate	m/min (fpm)	X: 20, Y: 20, Z: 10 (X: 66, Y: 66, Z: 33)					
W-axis travel rate	m/min (fpm)	4.8 (15.7)					
<b>Automatic Tool Changer</b>							
Tool shank		MAS BT50					
Pull stud		MAS2					
Tool magazine capacity	tools	50 [80, 100, 120, 180]					
Max tool diameter	mm (in)	w/ adjacent tools: ø135 (5.31), w/o adjacent tools: ø230 (9.06)					
Max tool length	mm (in)	400 (15.75)					
Max tool mass	kg (lb)	25 (55)					
Tool selection		Fixed address					
<b>Motors</b>							
Spindle drive	kW (hp)	26/22 (35/30) (30 min/cont)					
Axis feed drives	kW (hp)	X: 14.0, Y: 6.4, Z: 5.2 x 2 (X: 18.6, Y: 8.5, Z: 6.9 x 2)					
Crossrail elevating	kW (hp)	W: 5.6 x 2 (7.5 x 2)					
<b>Power Sources</b>							
Electrical power supply	kVA	60 <sup>3</sup>					
Compressed air supply	L/min (ANR)	1,040 (0.5 MPa or more) <sup>3</sup>					
<b>Machine Size</b>							
Height	mm (in)	6,420 [6,620] (252.76 [260.63])			6,700 [6,900] (263.78 [271.65])		
Floor space (machine only)	mm (in)	7,370 x 10,730 (290.16 x 422.44)	7,370 x 12,830 (290.16 x 505.12)	7,370 x 16,430 (290.16 x 646.85)	7,870 x 10,730 (309.84 x 422.44)	7,870 x 12,830 (309.84 x 505.12)	7,870 x 16,430 (309.84 x 646.85)
Mass (machine only)*4	kg (lb)	46,000 (101,200)	52,000 (114,400)	60,000 (132,000)	53,000 (116,600)	58,000 (127,600)	67,000 (147,400)
CNC		OSP-P500M					

[ ]: option \*1. In the case of APC specs (option), please also consider the high column because the distance from the end of the spindle to the top of the pallet will be shorter. \*2. Deceleration near both ends of Y-axis travel \*3. Standard specs \*4. With 50-tool magazine, 2-station AAC

## MCR-S Standard Specifications

Main motor and standard electricals		Magazine tool loader	
Spindle cooler, ram slideway, feed axis coolers	Oil temperature controller	ATC magazine safety fence	
AbsoScale detection (X-Y-Z axes)		Column slideway covers	
Thermo-Friendly Premium specifications	TAS-S included	Crossrail clamp system	
Synchronized NC W-axis		Seesaw pendant operation panel	Elevation: 600 mm
Hydraulic unit		Work lamp	LED
Automatic Tool Changer (ATC)	50 tools	Status indicator	3-color LED
Z-axis double ball screw		Door interlock	
Full length gutter	Both machine sides	Tool kit	
ATC air blower (blast)		Tapered bore cleaning bar	
Spindle air curtain		Tool box	

## MCR-S Kit Specifications

Machine kit specs	Kit	S	A	P	AP
Attachment head ATC		●	●	●	●
Attachment head auto attaching/indexing unit (AAC)		●	●	●	●
Attachment head manual tool changing		●	●	●	●
Attachment head coolant lines		●	●	●	●
Auto pallet changer (APC) preparations				●	●
X-axis 2.0 m travel extension (side shuttle APC)				●	●

## MCR-S Optional Specifications

Automatic pallet changer (APC)	2-pallet side shuttle (2.0 m extension in X-axis travel)	Auto attachment changer (AAC)	2 stations to 7 stations
Optional Z-axis travel	1,000 mm	Attachment head	Please consult
Coolant system		Dust-proofing	
Coolant tank	500 L, 1,000 L	NC rotary tables	NC rotary table, inclined rotary table
Coolant heater/cooler		Mist collector	
Oil skimmer		Dust collector	
Filtration system		Full-enclosure shielding	Column front/back covers, w/o ceiling With ceiling
Semi-dry machining	Thru-spindle, nozzle	Auto Attachment Head Compensation	
Thru-spindle coolant*	High/low pressure switch (2 MPa, 7 MPa)	3D Smart Calibration System	Includes linear axis error measurement, spatial compensation, and accuracy stability diagnosis
Centralized coolant application			
Coolant pump	0.75 kW, 1.1 kW	Auto tool length compensation & breakage detection	Touch sensor system, Laser sensor system
Oil mist coolant	Insert nozzle	Auto gauging & auto zero offset	Touch probe
Oil-hole coolant system	High/low pressure switch (2 MPa), Simple system	In-machine chip conveyors	Full length, lift-up type Half length, lift-up type
Chip air blower (blast)		Chip flushers	Crossrail shower (L/R column front), front/back gutters with telescopic covers, workpiece wash gun
ATC tool magazine capacity	80, 100, 120, 180 tools	Collection chip conveyors	Hinged, hinge + scraper (w/ drum filter) Hinged + magnetic separator
ATC tools	Heavy tool (35 kg x 120 mm)	Chip buckets	L type, H type
Tool shank profile	CAT 50, DIN 50	Pendant arms	Parallel linked, manual, electric, floor mounted, front/back travel types
Pull-stud shape	MAS1, special CAT	Foundation methods	Chemical anchors, foundation bolts, no foundation bolts (foundation pad only)
Table T-slot width	20H7, 22H7, 28H7	Machine foundation pit work	50 to 1,400 mm, Please consult
Table cross-groove width	Please consult for width depth, pitch	Optional control cabinet positions	
Optional table width	+300 mm		
High column specs	200 mm increments (please inquire for +400 mm or higher)		
Optional W-axis travel	Standard travel +200 mm (please inquire for +400 mm or higher)		
Ram oil pan slush collector			
Attachment head accelerator preps			
Angle head preps			

\* Okuma pull stud required for Thru-Spindle Coolant

# A next-generation CNC that makes manufacturing DX (digital transformation) a reality

## OSP-P500

### Improved productivity and stable production

As Your Single Source for M-E-I-K (Mechanics - Electronics - IT - Knowledge) merging technology, Okuma offers this CNC to build an advanced "digital twin" that faithfully reproduces machine control and machining operations and creates new value. In addition, Okuma offers productivity improvement and stable production with ease of use that allows customers to use their machining know-how, an energy-saving solutions that achieve both high accuracy/productivity and eco-friendly products, with robust security protection against increasing threats of cyber-attacks.



15-inch operation panel

### Faithful reproduction of machines and processing — Digital support for shop floor work

#### Digital Twin (option)

“Okuma’s **two digital twins**” made possible by an office PC and a next-generation CNC reduce machine downtime and improve machine utilization

Simulation using the latest machine information can be achieved with an office PC and OSP-P500 installed on the physical machine. This enables preparation for machining in advance in the office environment (front loading). Preparing machining for the next part while continuing machining can reduce the preparation time for the physical machine. When a problem occurs on the shop floor, it can be solved quickly on site without going back to the office.

#### 1 Digital Twin On PC\* Simulate shop machines in the office

Front loading is performed with the actual status matched with the data on the office PC to further improve productivity. Highly accurate pre-verification minimizes trial and error in first part machining, and reduces machine downtime to the minimum.

\* The PC software is to be used with one package for one machine.

#### 2 Digital Twin On Machine Simulating the CNC of a real machine

Super-fast and super-accurate machining simulations are performed with the CNC of a real machine on-site to minimize machining preparation work. Actual machining can be started immediately, greatly improving the operating rate of the machine.

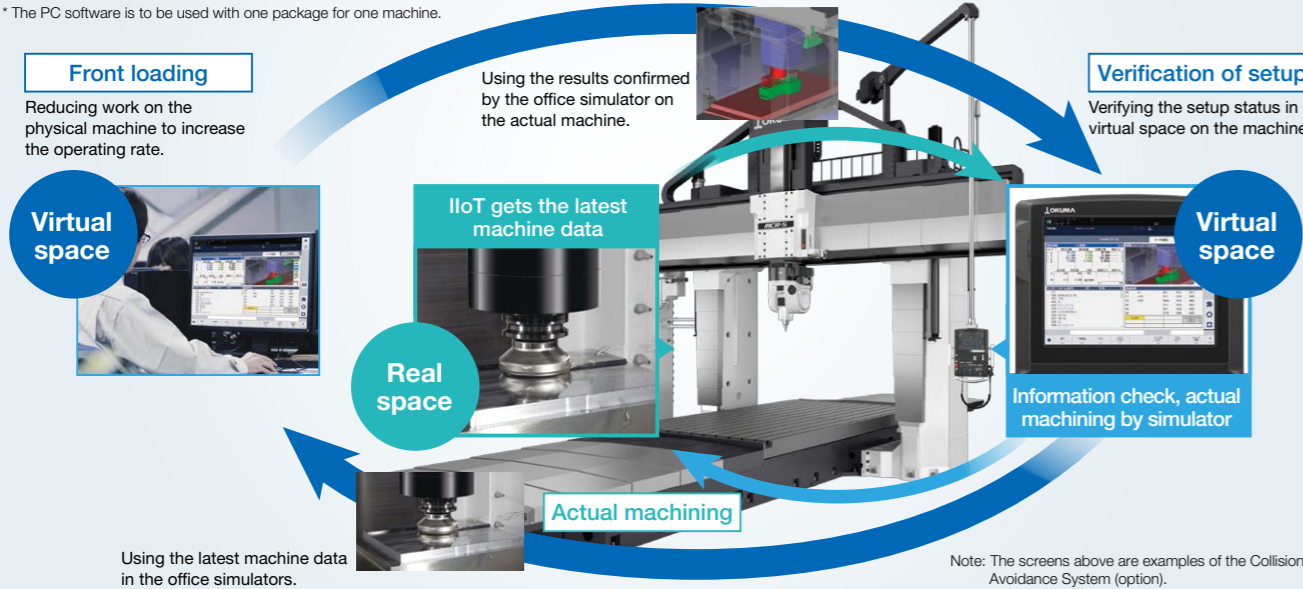

Note: The screens above are examples of the Collision Avoidance System (option).

### Connect Plan Get Connected, Get Started, and Get Innovative with Okuma "Monozukuri"

#### Connect, Visualize, Improve

Okuma's Connect Plan is a system that provides analytics for improved utilization by connecting machine tools and visual control of factory operation results and machining records. Simply connect the OSP and a PC and install Connect Plan on the PC to see the machine operation status from the shop floor, from an office, from anywhere. The Connect Plan is an ideal solution for customers trying to raise their machine utilization.

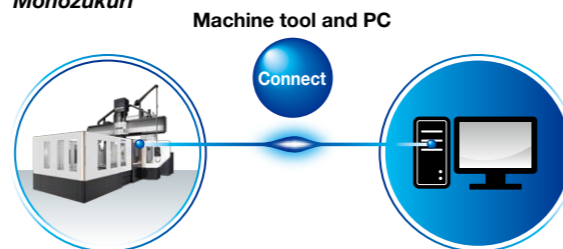

### OSP-P500M standard specifications

Basic specs	Control	X, Y, Z, W, simultaneous 4 axis, spindle control (1 axis)
	Position feedback	OSP full range absolute position feedback (zero-point return not required)
	Coordinate functions	Machine coordinate system (1 set), work coordinate system (20 sets)
	Min/max command	±99999.999 mm, ±9999.9999° 8-digit decimal, command units: 0.001 mm, 0.01 mm, 1 mm, 0.0001°, 0.001°, 1°
	Feed	Cutting feed override: 0 to 200%, rapid traverse override 0 to 100%
	Spindle control	Direct spindle speed commands, override 30 to 300%, multi-point indexing
	Tool compensation	No. of registered tools: Max 999 sets, tool length/radius compensation: 3 sets per tool
	Display	15-inch color LCD + multi-touch panel operations
	Security	Operator authentication, Lock screen, OSP-VPSII-STD (Virus Protection System)
	Programming	Program capacity
Program operations		Scheduled program, fixed cycle, G-/M-code macros, arithmetic, logic statements, math functions, variables, branch commands, Coordinate calculate, area machining, coordinate convert, programming help, user task, keyway cycle
Operations		OSP suite "suite apps" to graphically visualize and digitize information needed on the shop floor, "suite operation" enable one-touch access to "suite apps".
Easy Operation	MacMan plus	"Single-mode operation" to complete a series of operations. Advanced operation panel/graphics facilitate smooth machine control
	Machine operations	Machining management: aggregation and display of machining records, operating records and problem information, Visualization of power consumption, file output
	Machine operations	Operation help, load meter, alarm help, sequence return, manual interrupt/auto return, pulse handle overlap, parameter I/O, PLC monitor, auto power shut-off
Communications / Networking	USB (2 ports), Ethernet, DNC-T1, Smart I/F	
High speed/accuracy specs	Thermo-Friendly Premium (TAS-S: Thermo Active Stabilizer – Spindle, TAS-C <sup>2</sup> : Thermo Active Stabilizer – Construction for large machines), AbsoScale detection (X-Y-Z axes), Pitch error compensation, HI-G control, SERVO NAVI <sup>1</sup> , Cycle time reduction (operation time reduction, machining time shortening, easy parameter setting), Hyper-Surface II	
Energy-saving function	ECO suite plus	ECO Idling Stop, ECO Operation, oil temperature controller auto control, ECO Power Monitor <sup>2</sup>
	Power Regeneration System	Regenerative power is used when the spindle and feed axes decelerate to reduce energy waste.

\*1. For Deflection Auto Adjustment included in the specs, X-Y axes AbsoScale detection specs are needed.

\*2. The power display shows estimated values. When precise electrical values are needed, select the wattmeter option.

### OSP-P500M kit specifications/optional specifications

Item	Kit specs	NML				AOT				DT				DT AOT			
		E	D	E	D	E	D	E	D	E	D	E	D	E	D		
<b>Digital Twin</b>																	
Virtual Machining																	
Quick Modeling																	
OPC UA for Machine Tools																	
OSP API KIT																	
<b>Interactive functions</b>																	
Advanced One-Touch IGF-M (w/ Real 3-D Simulation)																	
Interactive MAP (I-MAP)																	
Smart OSP Operation																	
<b>Programming</b>																	
Operation buffer 10 MB																	
Program notes (MSG)																	
Auto scheduled program update																	
Block skip; 9 sets																	
Program branch; 9 sets																	
Coordinate system select (Std: 20 sets)																	
100 sets																	
200 sets																	
400 sets																	
Helical cutting (within 360 degrees)																	
3-D circular interpolation																	
Skip																	
Synchronized Tapping II																	
Arbitrary angle chamfering																	
Cylindrical side facing																	
Tool max rotational speed setting																	
F1-digit feed	External switch type, parameter type																
Programmable travel limits (G22, G23)																	
Slope machining	Type I, Type II																
Axis name designation																	
3-D tool compensation																	
Coordinate change and drawing conversion	Programmable mirror image (G62) Enlarge/reduce (G50, G51)																
User task	Common variables 1,000, 2,000 pcs G code macros: 80 sets added I/O variables (16 each)																
Sequence stop																	
Sequence return	Mid-block sequence return																
Tool wear compensation	Includes input restriction																
Tool life management	Includes warning																
Leading edge offset																	
Inverse time feed																	
Alignment compensation																	
<b>External I/O communication</b>																	
RS-232C connector																	
DNC connection	DNC-T3, DNC-B, DNC-DT DNC-C/Ethernet																
<b>Item</b>																	
<b>Gauging</b>																	
Auto tool length offset/breakage detection																	
Auto Workpiece Gauging/Auto zero offset																	
Manual gauging (w/o sensor)																	
Interactive gauging (touch sensor, touch probe required)																	
<b>Monitoring</b>																	
One-Touch Spreadsheet																	
Collision Avoidance System																	
Real 3-D Simulation																	
Simple load monitor	Spindle overload monitor																
NC operation monitor	Hour meter, workpiece counter																
Status indicator																	
Operation end buzzer																	
Workpiece counters on machine																	
Tool breakage no-load detection																	
MOP-TOOL	Adaptive control, overload monitor																
AI machine diagnostics*	Feed axes																
Machine Status Logger																	
Cutting Status Monitor																	
Machining Navi M-gII (cutting condition search)																	
Feed axis retraction																	
Tool retract cycle																	
<b>Automation / Unattended operation</b>																	
Warm-up (calendar timer)																	
External program	Button, rotary switch BCD (2-digit, 4-digit)																
<b>High-speed, high-precision</b>																	
Auto Attachment Head Compensation																	
Straightness compensation																	
Dynamic displacement compensation																	
0.1 μm control (command unit for linear axes)																	
3D Smart Calibration System																	
Accuracy Stability Diagnosis Function																	
Simultaneous 5-axis kit																	
<b>ECO suite plus</b>																	
ECO Power Monitor	On-machine wattmeter																
Spindle Power Peak Limiter																	
Energy-saving hydraulic unit	ECO Hydraulics																
External output interface of consumed electricity																	
<b>Other</b>																	
Circuit breaker																	
OSP-VPSII-EX (Virus Protection System)																	
Pulse handles	2 pcs, 3 pcs																
External M codes [4 sets, 8 sets]																	

Notes: NML: Normal kit, AOT: Advanced One-Touch IGF-M kit, DT: Digital Twin kit, DT AOT: Digital Twin Advanced One-Touch IGF-M, E: Economy, D: Deluxe VE and VD kits are also equipped with the Digital Twin on PC function, allowing running from a PC. Specifications, etc. are subject to change without notice.

\* With AbsoScale detection specs, ball-screw wear detection is possible.

**Table dimensions**

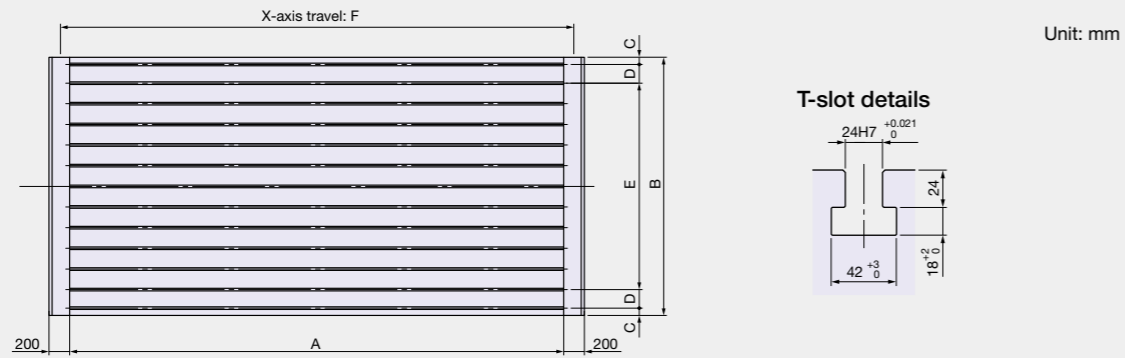

Unit: mm

Size	A	B	C	D	E	F
25	25 x 40	4,000	70	130	8x200 =1,600	4,200
	25 x 50	5,000				5,200
	25 x 65	6,500				6,700
30	30 x 40	4,000	180	10x200 =2,000	4,200	
	30 x 50	5,000			5,200	
	30 x 65	6,500			6,700	

**Working Range Drawings**

**Extension head, 90° angular head**  
Max height (300-mm tool length)

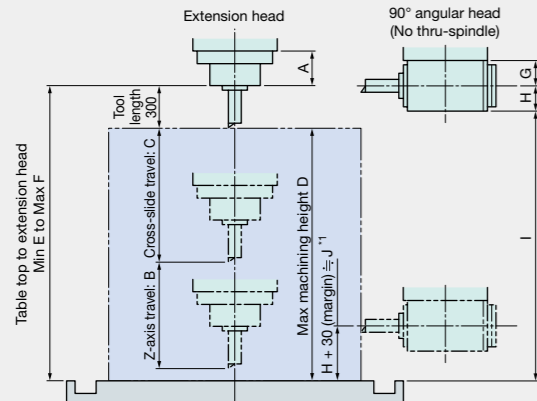

\*1. "J"; to avoid interference between attachment head and table.

**90° angular head**  
Max width x length (300-mm tool length)

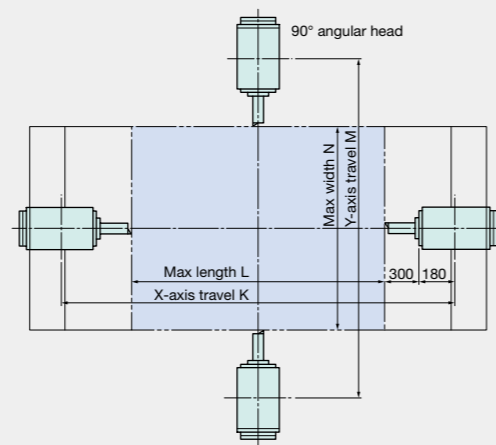

Unit: mm

Size	EW BC*	A		B	C	D		E	F		
		L250 Spec	L350 Spec			L250 Spec	L350 Spec		L250 Spec	L350 Spec	
25	2,650	250	350	800	1,000	1,250	1,150	0	1,550	1,450	
									25 x 50		
									25 x 65		
30	3,150				1,200	1,450	1,350		1,750	1,650	
									30 x 50		
									30 x 65		

Unit: mm

Size	EW BC*	G		H		I		J	
		L150 Spec	L250 Spec	L150 Spec	L250 Spec	L150 Spec	L250 Spec	L150 Spec	L250 Spec
25	2,650	150	250	112	117	1,538	1,433	140	150
						25 x 50			
						25 x 65			
30	3,150					1,738	1,633		
						30 x 50			
						30 x 65			

**Remarks:**

- The upper drawings and tables show the working range when a 300-mm long tool is attached to the extension or, 90° angular heads.
- Dimensions may change depending on specifications, so please refer to actual delivered machine specifications.

\* Effective width between columns

**Dimensional Drawing / Installation Drawing**

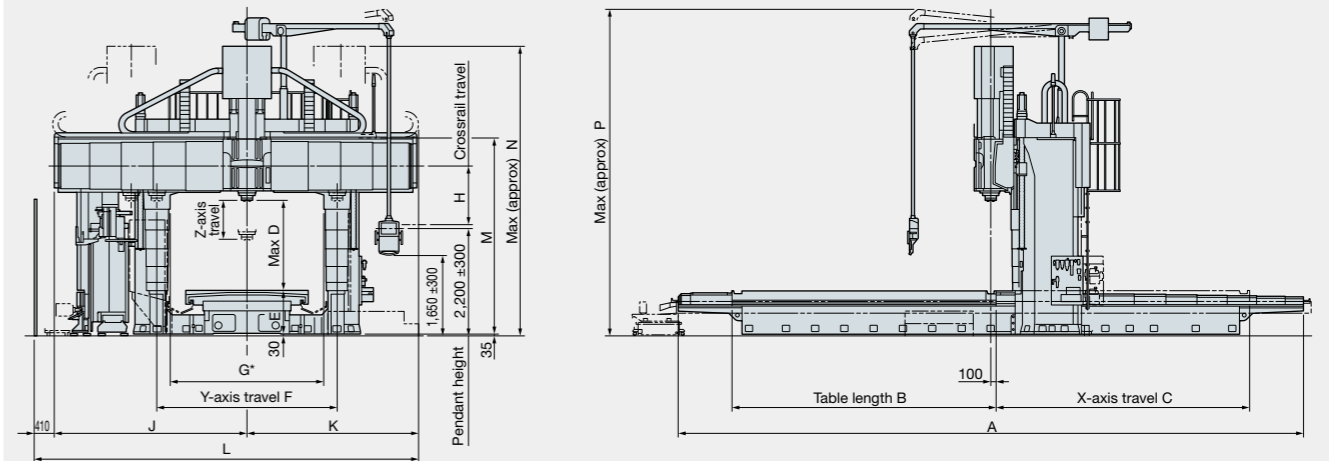

\* Effective width between columns

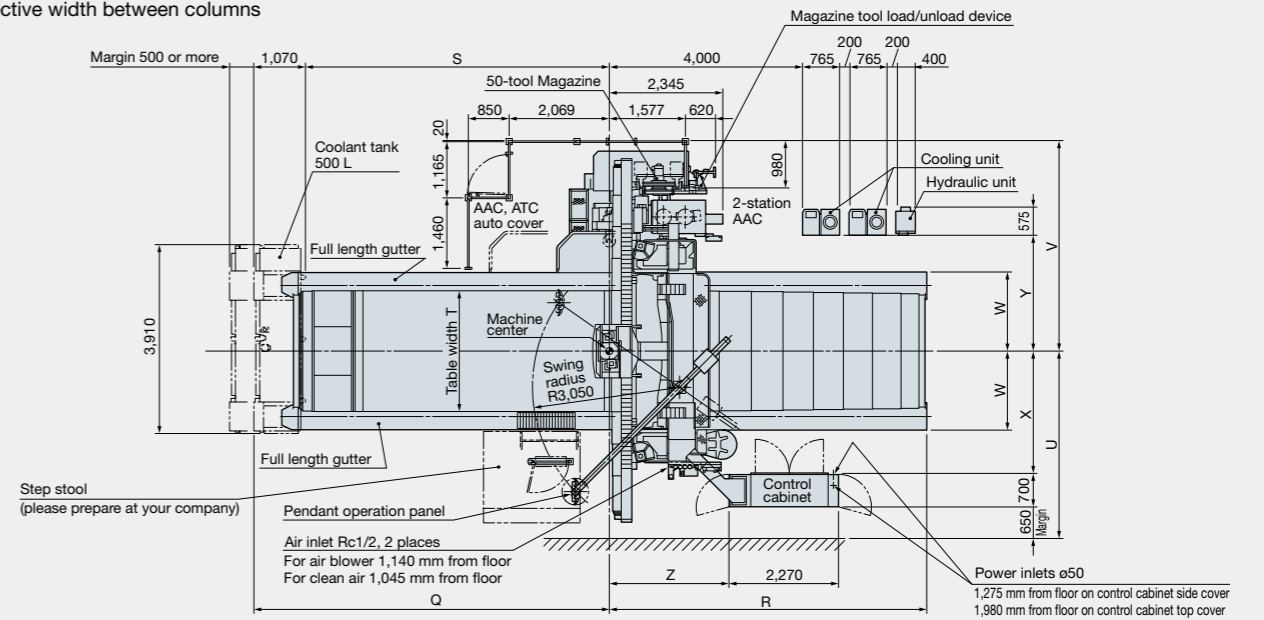

This drawing show outline of standard machine. These dimensions will change if optional specifications are selected. And depending on the destination country or region, full enclosure or safety fences are required.

Unit: mm

Size	A	B	C	D		E	F	G	H	J	K	L	M	N	P	
				*1	*2											
25	25 x 40	10,730	4,400	4,200	1,650	1,550	850	3,200	2,650	1,000	3,700	3,250	7,360	3,650	5,690 [5,890] <sup>*3</sup>	6,420 [6,620] <sup>*3</sup>
	25 x 50	12,830	5,400	5,200												
	25 x 65	16,430	6,900	6,700												
30	30 x 40	10,730	4,400	4,200	1,850	1,750	900	3,700	3,150	1,200	3,950	3,510	7,870	4,025	5,940 [6,140] <sup>*3</sup>	6,700 [6,900] <sup>*3</sup>
	30 x 50	12,830	5,400	5,200												
	30 x 65	16,430	6,900	6,700												

Size	Q	R	S	T	U	V	W	X	Y	Z	
25	25 x 40	6,310	5,520	5,240	2,000	3,630	4,110	1,386	2,280	2,150	2,430
	25 x 50	7,360	6,570	6,290							
	25 x 65	9,160	8,370	8,090							
30	30 x 40	6,310	5,520	5,240	2,500	3,880	4,360	1,636	2,530	2,400	2,480
	30 x 50	7,360	6,570	6,290							
	30 x 65	9,160	8,370	8,090							

Note: Dimensions may change depending on specifications. Please refer to final delivered machine specifications.  
\*1. With 150 mm long extension head  
\*2. With 250 mm long extension head  
\*3. Z-axis travel 1,000 mm spec

When using Okuma products, always read the safety precautions mentioned in the instruction manual and attached to the product.

●The specifications, illustrations, and descriptions in this brochure vary in different markets and are subject to change without notice.  
Pub.No.MCR-S-E-(3a)-100 (Mar-2025)



**OKUMA Corporation**

Oguchi-cho, Niwa-gun,  
Aichi 480-0193, Japan  
TEL: +81-587-95-7825 FAX: +81-587-95-6074