

LU EX Series
SIMUL TURN

LU3000EX/ LU4000EX

2-Saddle CNC Lathes



LU EX Series

SIMUL TURN

2-Saddle CNC Lathes

LU3000EX/LU4000EX



Max power 2-saddle turning centers for even higher productivity

Huge productivity gains at higher performance levels

Achieve the best production system with our wide-ranging lineup

Wide array of intelligent technologies are powerful support for operator



SIMUL TURN **LU3000EX**



SIMUL TURN **LU4000EX** (MY specifications)

Photographs used in this brochure may show optional equipment.

Max power 2-saddle turning centers for even higher productivity



Shaft shapes are machined with high efficiency

● Part name: Spindle
● Size: $\phi 145 \times 465$ mm

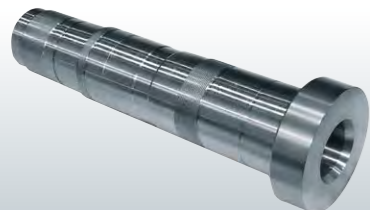

● Part name: Drive shaft
● Size: $\phi 100 \times 500$ mm

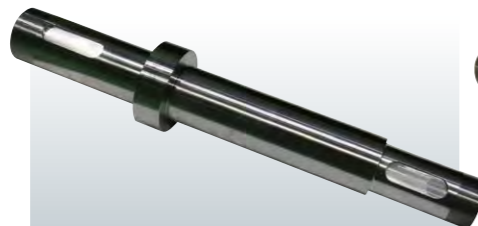

● Part name: Worm screw
● Size: $\phi 85 \times 500$ mm



Many types of machining with the flexibility of 4 axes

Huge reduction in machining time with simultaneous 4-axis machining on upper and lower turrets

In other words, simultaneous OD/OD or ID/OD operations drastically reduce cycle times. In addition with optional shaft cradle or a steadyrest attached to the lower turret—the possibilities are endless.

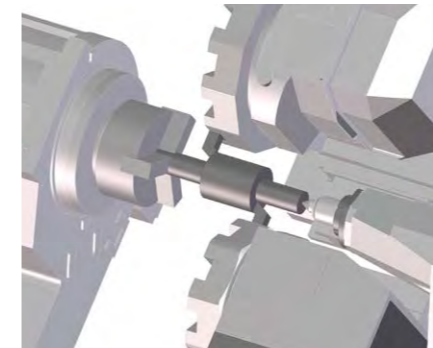

High-efficiency machining from simultaneous 4-axis turning

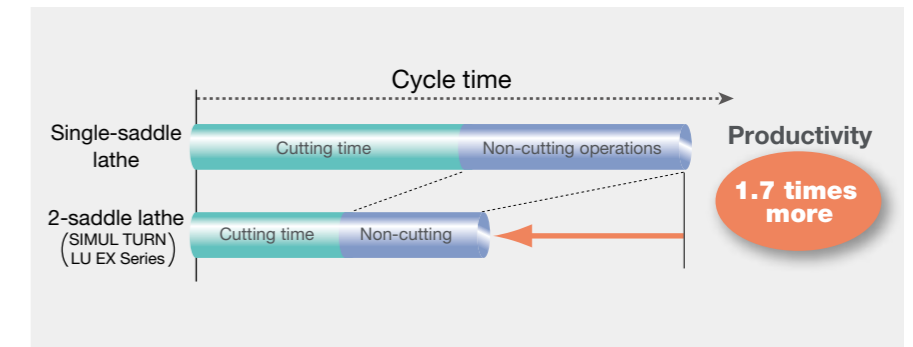

Turning long shafts with a steadyrest—without chatter

A steadyrest (option) mounted on the lower turret does provide steady workpiece support. With an NC programmed upper turret and simultaneous control, long shafts will always be supported near the cutting point.

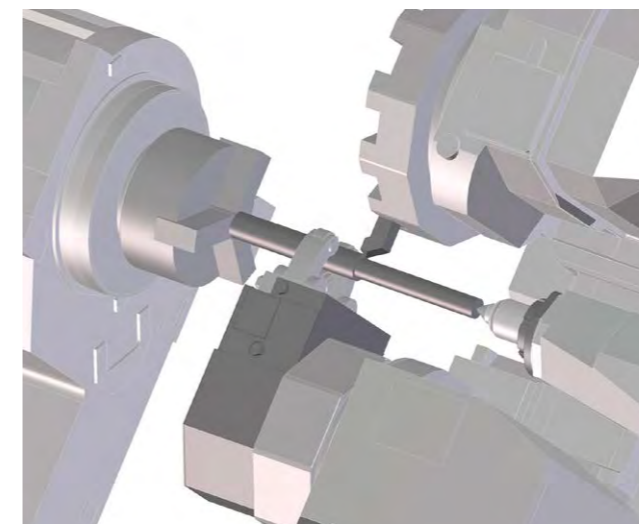

Prevents chatter with steadyrest support

Reducing operator burden by auto part load/unload

A shaft cradle (option) is attached to the lower turret to automate part load/unload, and reduce the workload of the operator.

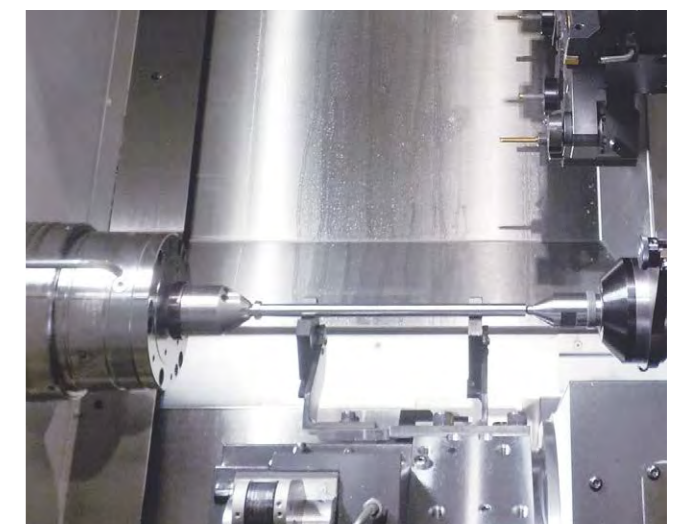

Shaft cradle reduces operator burden

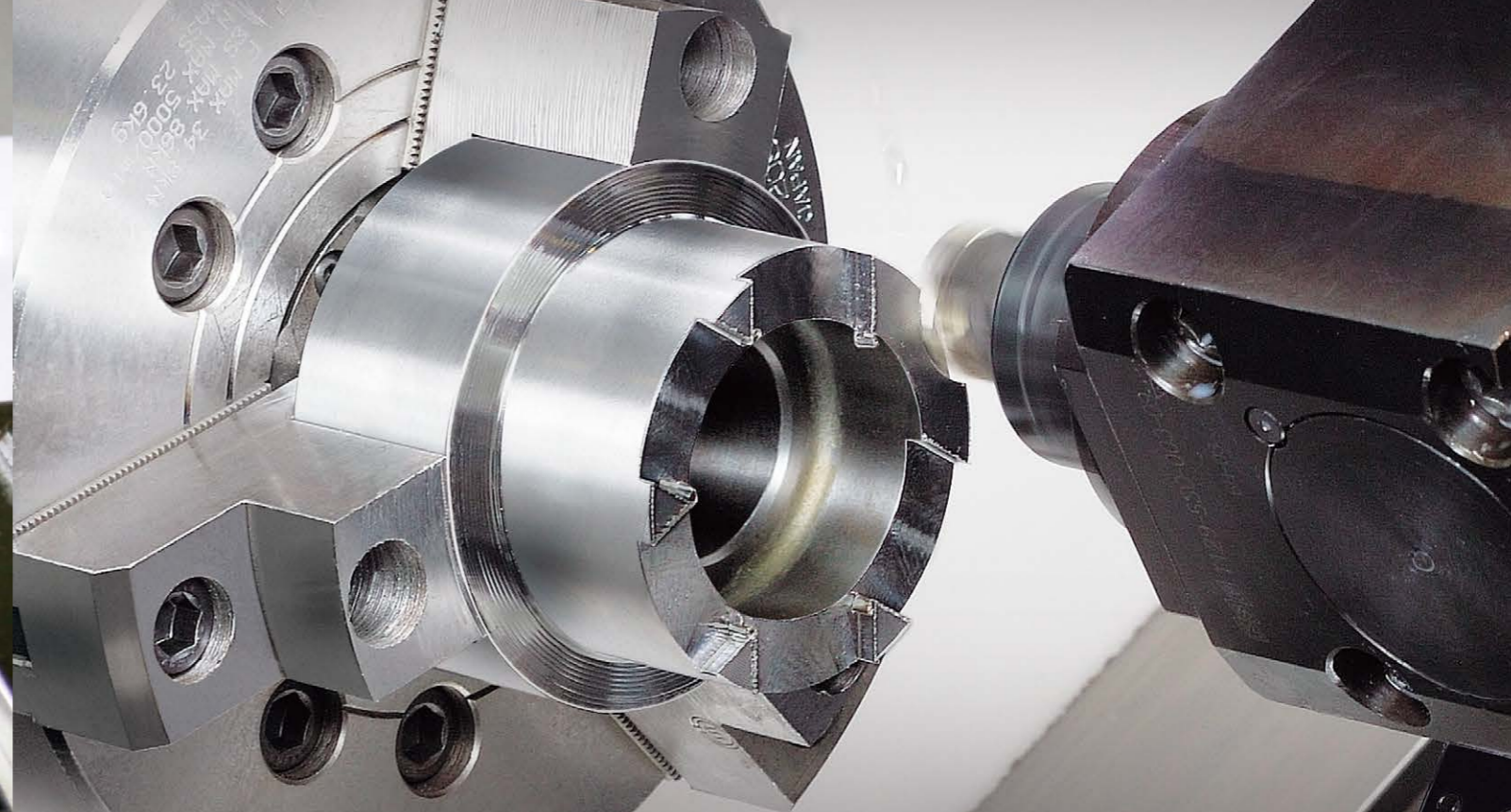
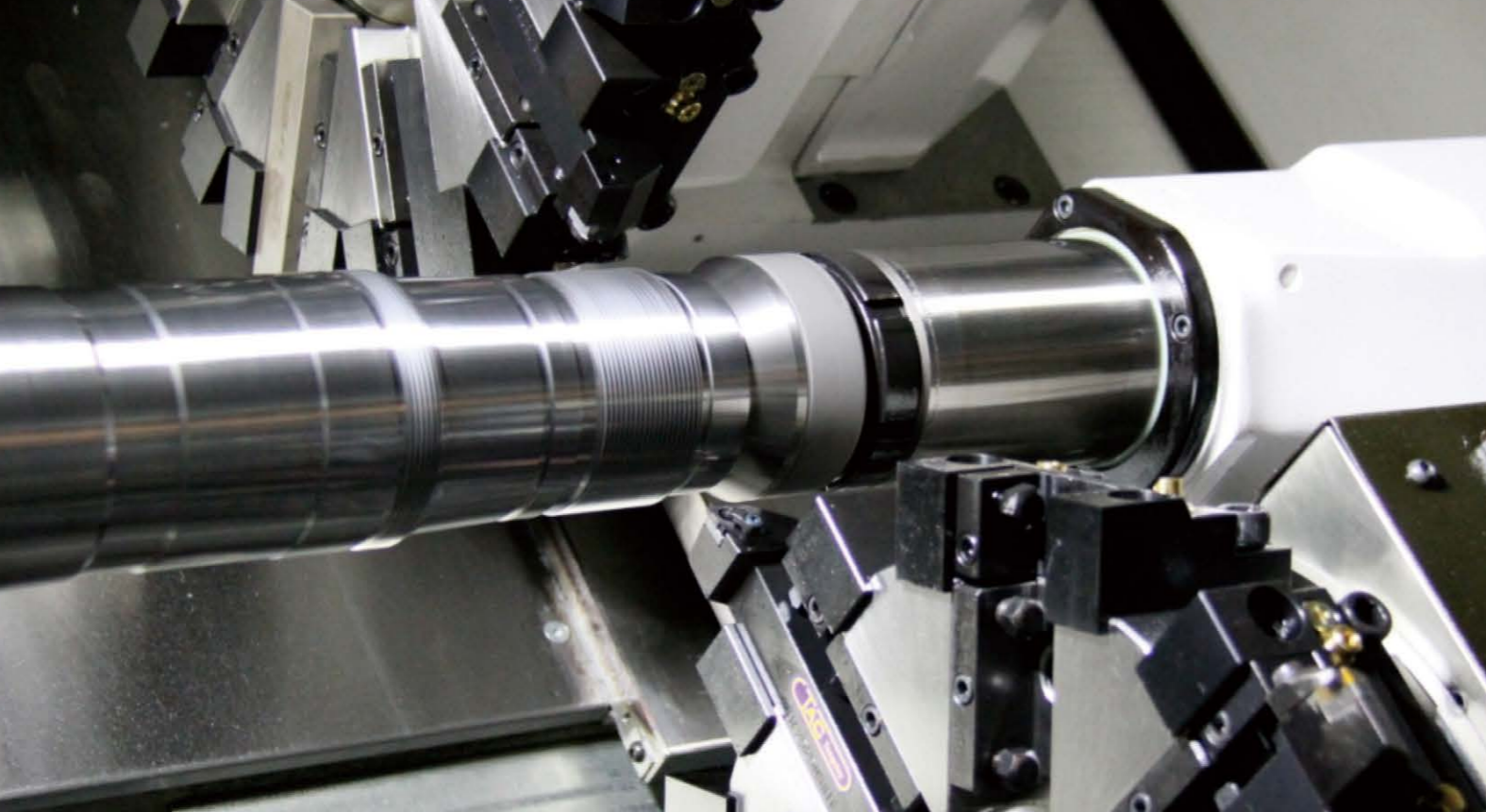

Highly accurate machining of shafts



Wide working ranges for upper and lower turrets

X-axis travel	LU3000 EX	LU4000 EX
Upper turret	260 mm	300 mm
Lower turret	160 mm	195 mm

Example of high accuracy machining (LU3000 EX actual data)

Roundness

- 0.3 μm (upper turret)/0.4 μm (lower turret)

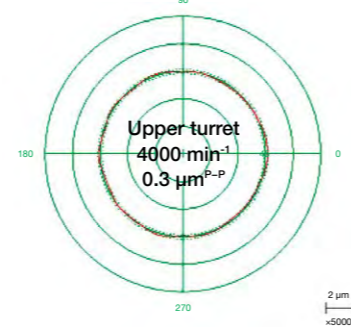

Surface roughness (tool edge uniformity)

- 0.2 μm (upper turret)/0.5 μm (lower turret)

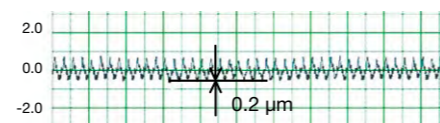

Powerful machining and rapid movements mean shorter cycle times

High-performance simultaneous (heavy) turning with power to spare (Actual data)

	<LU3000 EX>	<LU4000 EX>
Turning	Heavy-duty: 4.4 mm² (379 cm ³ /min)	Heavy-duty: 6.0 mm² (648 cm ³ /min)
● OD (S45C)	Cutting speed 150 m/min Cutting depth 8 mm Feed rate 0.55 mm/rev	Cutting speed 96 m/min Cutting depth 10 mm Feed rate 0.6 mm/rev
● ϕ 63 carbide insert drill (S45C)	Cutting speed 150 m/min Feed rate 0.23 mm/rev	ϕ 63 carbide insert drill Cutting speed 150 m/min Feed rate 0.23 mm/rev
Milling	Chip volume: 240 cm³/min	Chip volume: 240 cm³/min
● 7-Flute, carbide, ϕ 20 mm end mill (S45C)	Cutting speed 200 m/min Cutting depth 18 mm Feed rate 1.4 mm/rev Chip volume 240 cm ³ /min	7-Flute, carbide, ϕ 20 mm end mill Cutting speed 200 m/min Cutting depth 18 mm Feed rate 1.4 mm/rev Chip volume 240 cm ³ /min
● ϕ 20 carbide drill (S45C)	Cutting speed 135 m/min Feed rate 0.25 mm/rev	ϕ 28 carbide drill Cutting speed 90 m/min Feed rate 0.20 mm/rev
● Tapping (S45C)	M20 P2.5	M24 P3

Note: The "actual data" referred to above for this brochure represent examples, and may not be obtained due to differences in specifications, tooling, cutting conditions, and others.

Quick moving components shorten non-cutting times

Rapid feedrates	X-axis 25 m/min Z-axis 30 m/min	Turret indexing time	0.1 sec/index (LU3000 EX) 0.2 sec/index (LU4000 EX)
------------------------	------------------------------------	-----------------------------	--

Achieve the best production system with our wide-ranging lineup



Complete multitasking with Y-axis functions One chuck machining even with irregularly shaped workpieces

A variety of milling operations can be accommodated with high-accuracy, wide-range Y-axis travel using a double slide system. Achieves complete multitasking with a single chucking. (MY specifications)

	LU3000 EX	LU4000 EX
Y-axis travel	120 mm (+70 to -50)	140 mm (+70 to -70)
Y-axis rapid traverse	12.5 m/min	12.5 m/min

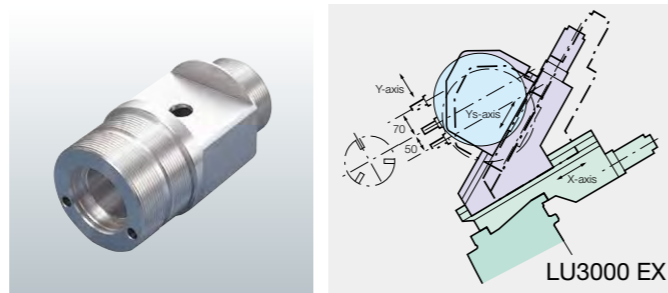

Sub-spindle for integrated front/back (1 machine) operations

With a sub-spindle, front and back machining can be done on a single machine. Since machining of both ends can be completed on one machine, workpiece storage space and post-process machines are unnecessary. (LU3000 EX only)

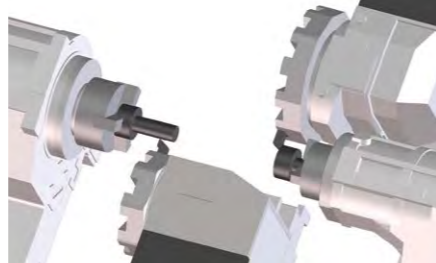

Simple automation with parts catcher (option)

Automation can be achieved easily with a simple mechanism in which the bucket swings and discharges finished parts outside the machine.

Spindle torque/output diagram

● LU3000 EX Turning spindle

Spindle speed 5,000 min⁻¹
Output 22/15 kW (30 min/cont)
Torque 427/280 N-m (10 min/cont)

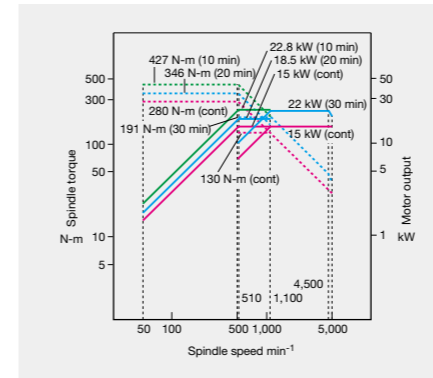

● LU3000 EX Big-Bore spindle (option)

Spindle speed 4,200 min⁻¹
Output 22/15 kW (30 min/cont)
Torque 427/280 N-m (10 min/cont)

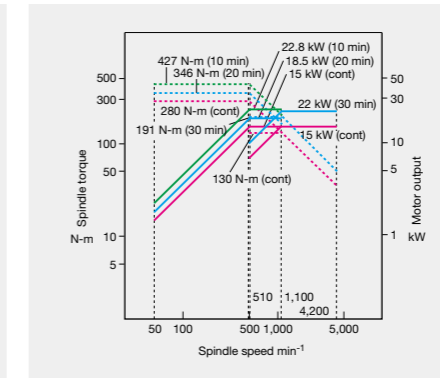

● LU3000 EX (W) Sub-spindle

Spindle speed 6,000 min⁻¹
Output 7.5/5.5 kW (20 min/cont)
Torque 159.2/116.7 N-m (20 min/cont)

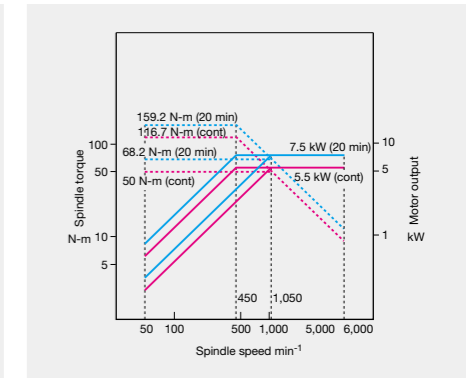

● LU4000 EX Turning spindle

Spindle speed 4,200 min⁻¹
Output 22/15 kW (30 min/cont)
Torque 700/477 N-m (30 min/cont)

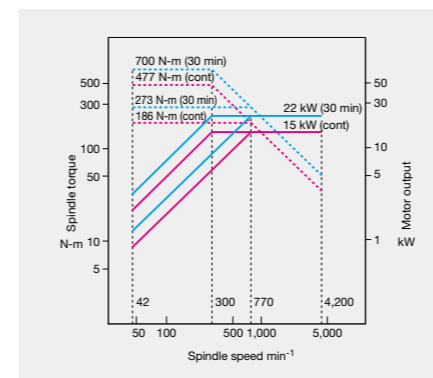

● LU4000 EX Big-Bore spindle (option)

● LU3000 EX Super Big-Bore spindle (option)

Spindle speed 3,000 min⁻¹
Output 22/15 kW (30 min/cont)
Torque 700/477 N-m (30 min/cont)

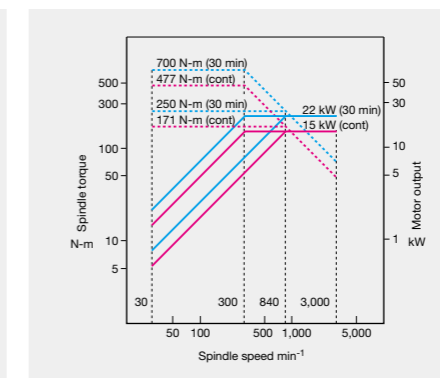

● LU4000 EX High Power Spindle (option)

Spindle speed 4,200 min⁻¹
Output 32/22 kW (20 min/cont)
Torque 955/657 N-m (10 min/cont)

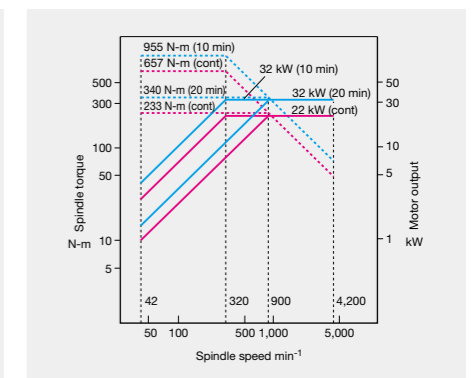

● LU3000 EX (M/2M/MY)

Upper turret milling tool spindle
Spindle speed 6,000 min⁻¹
Output 7.1/4.1 kW (25 min/cont)
Torque 40.4/23.4 N-m (25 min/cont)

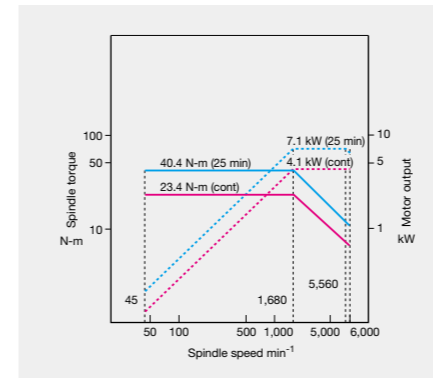

● LU3000 EX (2M/2MY)

Lower turret milling tool spindle
Spindle speed 6,000 min⁻¹
Output 5.5/3.7 kW (2 min/cont)
Torque 31.3/20.9 N-m (2 min/cont)

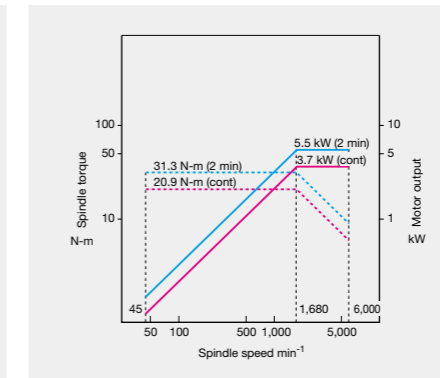

● LU4000 EX (M/MY) Milling tool spindle

Spindle speed 6,000 min⁻¹
Output 7.5/4.3 kW (25 min/cont)
Torque 58.1/33 N-m (25 min/cont)

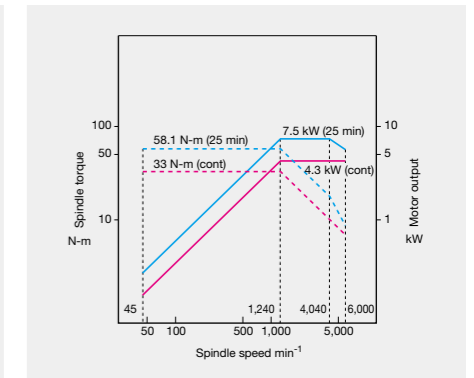

The unique approach of “accepting temperature changes.”

Thermo-Friendly Concept

Manageable Deformation—Accurately Controlled

The “Thermo-friendly concept” enables remarkable machining accuracy through original structural design and thermal deformation control technology. It frees you from troublesome dimensional compensation and warm-up. Exhibits excellent dimensional stability even during consecutive operation over long periods and environmental temperature change in the plant.

Fewer tool compensation checks

Compensation due to ambient temperature changes and temporary midday or evening machine stops is performed fewer times thanks to outstanding dimensional stability. This leads to better machine utilization, improving efficiency especially for mass-production machining.

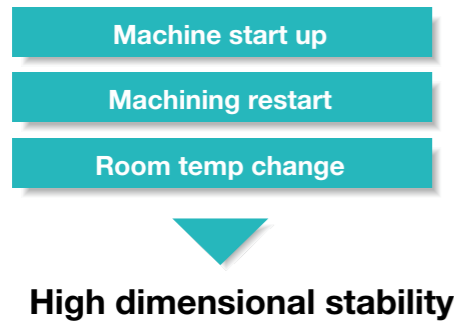

Simple machine construction

Machine designs that equalize ambient temperatures

Slanted-box bed

With the main units of the headstock and turret located on the box bed, the groundbreaking configuration of the equipment combines both thermal stability and high rigidity.

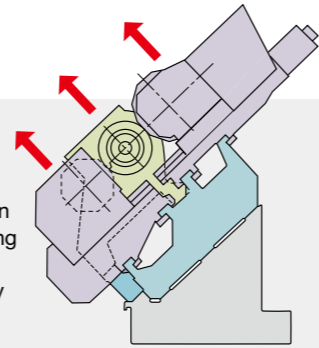

ECO suite plus

Next-Generation Energy-Saving System

A suite of energy saving applications for machine tools

ECO Idling Stop

Each unit operates only when required

Auxiliary equipment consume a substantial portion of the power used in a factory. This function enables each of them to be turned off when not needed to reduce power consumption. In addition to when automatic operation is suspended, it is now possible to stop idling during manual operation. Power consumption and carbon dioxide emissions are reduced without conscious effort by the operator.

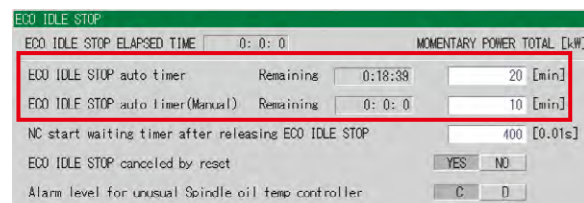

ECO Operation (option)

Intermittent/continuous operation of chip conveyor and mist collector during operation

ECO Power Monitor

On-the-spot check of energy savings

Spindle, feed axis, and auxiliary equipment power indicators are displayed separately on the OSP operation panel. The operation status of each device and power consumption/ carbon dioxide emissions can be checked on the spot.

Power Monitor check example



	INTE. POW[kWh]	INST. POW[kw]	-1	[min]	CURRENT
Spdl. oil temp ctrl.	14.0	0.6			
Axis oil temp ctrl.	14.0	0.6			
Coolant temp ctrl.	20.6	0.8			

The displayed values are examples.

World's first “Collision-Free Machine”

Collision Avoidance System

Collision prevention

(option)

“Concentrate on machining” without collision worries

NC controller (OSP) with 3D model data of machine components—workpiece, tool, chuck, fixture, headstock, turret, tailstock—performs real time simulation just ahead of actual machine movements. It checks for interference or collisions, and stops the machine movement immediately before collision. Machinists (novice or pro) will benefit from reduced setup and trial cycle times, and the confidence to focus on making parts.

Collision prevention during automatic operation

NC program is read in advance and axial travel commands are checked for interference with consideration of zero point and tool compensation values set in NC. Axial travel movement is stopped temporarily before collision occurs.

Collision avoidance in manual operation

Especially useful for machine operators setting up a job, collision avoidance in manual mode provides collision-free confidence and faster machining preparations.

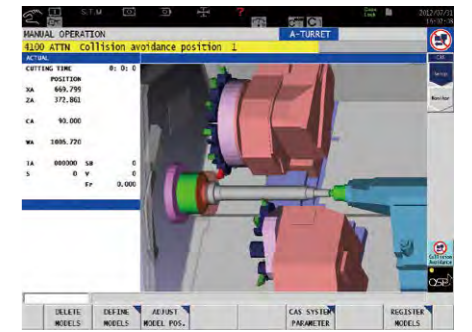

Virtual machine (interference check)

Find the best cutting condition for your application

Machining Navi L-gII

Cutting condition search for turning (Harmonic Spindle Speed Control) (option)

Varying the spindle speed in accordance with the best amplitude and period makes it possible to suppress chatter during turning operations. Tool life can be extended and cycles times reduced with use of the optimum cutting conditions, producing significant effects in deep-hole boring bar, threading, and grooving applications.

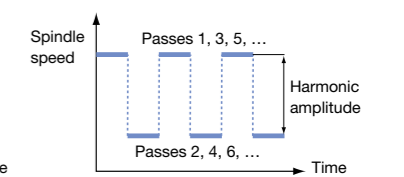
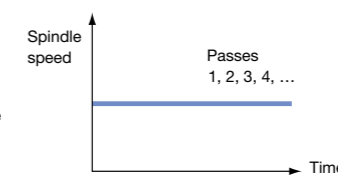
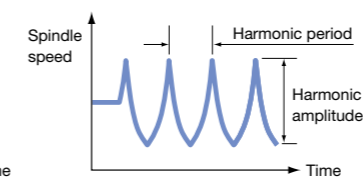
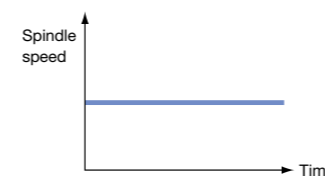

Machining Navi L-gII



Normal threading



Chatter marks

Machining Navi T-g Threading



Smooth surface

<LU3000 EX>

Machine Specifications

Item	unit	LU3000 EX (L)			LU3000 EX (M)			LU3000 EX (2M)			LU3000 EX (MY)			LU3000 EX (2MY)					
		2ST	2SC × 600	2SC × 1000	2ST	2SC × 600	2SC × 1000	2ST	2SC × 600	2SC × 1000	2ST	2SC × 550	2SC × 950	2ST	2SC × 550	2SC × 950			
Capacity	Swing over bed	mm (in) $\phi 580 (\phi 22.83)$																	
	Max turning dia, upper/lower	U: $\phi 410/L: \phi 250$ (U: $\phi 16.14/L: \phi 9.84$)			U: $\phi 340/L: \phi 220$ (U: $\phi 13.39/L: \phi 8.66$)			U: $\phi 340/L: \phi 180$ (U: $\phi 13.39/L: \phi 7.09$)			U: $\phi 340/L: \phi 220$ (U: $\phi 13.39/L: \phi 8.66$)			U: $\phi 340/L: \phi 180$ (U: $\phi 13.39/L: \phi 7.09$)					
	Max work length	350 (13.78)	600 (23.62)	1,000 (39.37)	350 (13.78)	600 (23.62)	1,000 (39.37)	350 (13.78)	600 (23.62)	1,000 (39.37)	350 (13.78)	550 (21.65)	950 (37.40)	350 (13.78)	550 (21.65)	950 (37.40)			
Travels	X-axis, upper/lower	mm (in) U: 260/L: 160 (U: 10.24/L: 6.30)																	
	Z-axis, upper/lower	U: 685/L: 615 (U: 26.97/L: 24.21)			U: 1,085/L: 1,015 (U: 42.72/L: 39.96)			U: 685/L: 600 (U: 26.97/L: 23.62)			U: 1,085/L: 1,000 (U: 42.72/L: 39.37)			U: 630/L: 615 (U: 24.80/L: 24.21)			U: 1,030/L: 1,015 (U: 40.55/L: 39.96)		
	Y-axis	mm (in) -																	
	C-axis (minimum control angle)	deg -			360 (0.001)			-			360 (0.001)			120 (4.72)					
Spindle	Speed	min ⁻¹ 50 to 5,000 [42 to 4,200, 30 to 3,000]																	
	Speed ranges	Two auto ranges (motor coil switching ranges)																	
	Spindle nozzle	JIS A2-6 [JIS A2-8, JIS A2-11]																	
	Bore dia	mm (in) $\phi 80 [\phi 91, \phi 112] [\phi 3.15 [\phi 3.58, \phi 4.41]]$																	
	Front bearing dia	mm (in) $\phi 120 [\phi 140, \phi 160] [\phi 4.72 [\phi 5.51, \phi 6.30]]$																	
Turret	Type, upper/lower	U: V12/L: V8			U: Multitasking V12/L: V8 (L radial)			U: Multitasking V12/L: Multitasking V8			U: Multitasking V12/L: V8 (L radial)			U: Multitasking V12/L: Multitasking V8					
	No. of tools, upper/lower	U: 12/L: 8			U: 12 (L/M)/L: 8			U: 12 (L/M)/L: 8 (L/M)			U: 12 (L/M)/L: 8			U: 12 (L/M)/L: 8 (L/M)					
	OD tool shank height	mm (in) $\square 25 (0.98)$																	
	ID tool shank dia	mm (in) $\phi 40 (\phi 1.57)$																	
	Turret index time	sec/1 index 0.1																	
Milling tool spindle	Spindle speed	min ⁻¹ - 45 to 6,000																	
Feed rate	Rapid traverse	m/min (fpm) X: 25, Z: 30 (X: 82, Z: 98)			X: 25, Z: 30 (X: 82, Z: 98), C: 200 min ⁻¹			X: 25, Z: 30 (X: 82, Z: 98), C: 200 min ⁻¹			X: 25, Z: 30 (X: 82, Z: 98), Y: 12.5 (Y: 41), C: 200 min ⁻¹								
Tailstock	Quill dia	mm (in) - $\phi 90 (\phi 3.54)$			- $\phi 90 (\phi 3.54)$			- $\phi 90 (\phi 3.54)$			- $\phi 90 (\phi 3.54)$			- $\phi 90 (\phi 3.54)$					
	Quill bore taper	- MT No. 5			- MT No. 5			- MT No. 5			- MT No. 5			- MT No. 5					
	Quill travel	mm (in) - 120 (4.72)			- 120 (4.72)			- 120 (4.72)			- 120 (4.72)			- 120 (4.72)					
Motor	Spindle	kW (hp) 22/15 (30/20) (30 min/cont)																	
	Milling tool	-			7.1/4.1 (9.5/5.5) (25 min/cont)			U: 7.1/4.1 (9.5/5.5) (25 min/cont) L: 5.5/3.7 (7.5/5) (2 min/cont)			7.1/4.1 (9.5/5.5) (25 min/cont)			U: 7.1/4.1 (9.5/5.5) (25 min/cont) L: 5.5/3.7 (7.5/5) (2 min/cont)					
	Axis drive	kW (hp) XA: 2.8 (3.7), XB: 2.2 (3), ZA: 3.5 (4.7), ZB: 3.5 (4.7)			XA: 2.8 (3.7), XB: 2.2 (3), ZA: 3.5 (4.7), ZB: 3.5 (4.7)			XA: 2.8 (3.7), XB: 2.2 (3), ZA: 3.5 (4.7), ZB: 3.5 (4.7)			XA: 2.8 (3.7), XB: 2.2 (3), ZA: 3.5 (4.7), ZB: 3.5 (4.7)			XA: 2.8 (3.7), XB: 2.2 (3), ZA: 3.5 (4.7), ZB: 3.5 (4.7), Ys: 3.5 (4.7)					
	Coolant pump (50 Hz/60 Hz)	kW (hp) 0.55/0.75 (0.7/1)																	
Machine size	Height*	mm (in) 2,080 (81.89) *			2,230 (87.80)			2,080 (81.89) *			2,230 (87.80)			2,507 (98.70) *			2,677 (105.39)		
	Floor space	mm (in) 2,950 × 2,176 (116.14 × 85.67)			3,980 × 2,478 (156.69 × 97.56)			2,950 × 2,176 (116.14 × 85.67)			3,980 × 2,478 (156.69 × 97.56)			2,950 × 2,176 (116.14 × 85.67)			3,980 × 2,478 (156.69 × 97.56)		
	Mass (w/ CNC)	kg (lb) 6,400 (14,080)			6,700 (14,740)			8,200 (18,040)			6,500 (14,300)			6,800 (14,960)			8,300 (18,260)		
CNC	OSP-P300LA																		

Item	unit	LU3000 EX (W)		LU3000 EX (MW)		LU3000 EX (2MW)	
		2SW × 600	2SW × 1000	2SW × 600	2SW × 1000	2SW × 600	2SW × 1000
Capacity	Swing over bed	mm (in) $\phi 580 (\phi 22.83)$					
	Max turning dia, upper/lower	U: $\phi 410/L: \phi 250$ (U: $\phi 16.14/L: \phi 9.84$)		U: $\phi 340/L: \phi 220$ (U: $\phi 13.39/L: \phi 8.66$)		U: $\phi 340/L: \phi 180$ (U: $\phi 13.39/L: \phi 7.09$)	
	Max work length	600 (23.62)	1,000 (39.37)	600 (23.62)	1,000 (39.37)	600 (23.62)	1,000 (39.37)
Travels	X-axis, upper/lower	mm (in) U: 260/L: 160 (U: 10.24/L: 6.30)					
	Z-axis, upper/lower	U: 685/L: 610 (U: 26.97/L: 24.02)		U: 1,085/L: 1,010 (U: 42.72/L: 39.76)		U: 576/L: 610 (U: 22.68/L: 24.02)	
	W-axis	mm (in) 610 (24.02)		1,010 (39.76)		610 (24.02)	
	C-axis (minimum control angle)	deg -					
Spindle	Speed	min ⁻¹ Main: 50 to 5,000 [42 to 4,200, 30 to 3,000], Sub: 50 to 6,000					
	Speed ranges	Two auto ranges (motor coil switching ranges)					
	Spindle nozzle	Main: JIS A2-6 [JIS A2-8, JIS A2-11], Sub: $\phi 140$ flat		Main: JIS A2-6 [JIS A2-8, JIS A2-11], Sub: $\phi 140$ flat		Main: JIS A2-6 [JIS A2-8, JIS A2-11], Sub: $\phi 140$ flat	
	Bore dia	mm (in) Main: $\phi 80 [\phi 91, \phi 112] [\phi 3.15 [\phi 3.58, \phi 4.41]]$, Sub: $\phi 43 (1.69)$					
	Front bearing dia	mm (in) Main: $\phi 120 [\phi 140, \phi 160] [\phi 4.72 [\phi 5.51, \phi 6.30]]$, Sub: $\phi 80 (3.15)$					
Turret	Type, upper/lower	U: V12/L: V8		U: Multitasking V12/L: V8 (L radial)		U: Multitasking V12/L: Multitasking V8	
	No. of tools, upper/lower	U: 12/L: 8		U: 12 (L/M)/L: 8		U: 12 (L/M)/L: 8 (L/M)	
	OD tool shank height	mm (in) $\square 25 (0.98)$					
	ID tool shank dia	mm (in) $\phi 40 (\phi 1.57)$					
	Turret index time	sec/1 index 0.1					
Milling tool spindle	Spindle speed	min ⁻¹ - 45 to 6,000					
Feed rate	Rapid traverse	m/min (fpm) X: 25, Z: 30, W: 15 (X: 82, Z: 98, W: 49)		X: 25, Z: 30 (X: 82, Z: 98), W: 15 (W: 49), C: 200 min ⁻¹			
Motor	Spindle	kW (hp) Main: 22/15 (30/20) (30 min/cont), Sub: 7.5/5.5 (10/7.5) (20 min/cont)					
	Milling tool	-		7.1/4.1 (9.5/5.5) (25 min/cont)		U: 7.1/4.1 (9.5/5.5) (25 min/cont)/L: 5.5/3.7 (7.5/5) (2 min/cont)	
	Axis drive	kW (hp) XA: 2.8 (3.7), XB: 2.2 (3), ZA: 3.5 (4.7), ZB: 3.5 (4.7), W: 3.5 (4.7)		XA: 2.8 (3.7), XB: 2.2 (3), ZA: 3.5 (4.7), ZB: 3.5 (4.7), W: 3.5 (4.7)		XA: 2.8 (3.7), XB: 2.2 (3), ZA: 3.5 (4.7), ZB: 3.5 (4.7), W: 3.5 (4.7)	
	Coolant pump (50 Hz/60 Hz)	kW (hp) 0.55/0.75 (0.7/1)					
Machine size	Height*	mm (in) 2,080 (81.89) *		2,230 (87.80)		2,080 (81.89) *	
	Floor space	mm (in) 3,750 × 2,176 (147.64 × 85.67)		4,040 × 2,478 (159.06 × 97.56)		3,750 × 2,176 (147.64 × 85.67)	
	Mass (w/ CNC)	kg (lb) 7,100 (15,620)		8,600 (18,920)		7,200 (15,840)	
CNC	OSP-P300LA						

[] : option * Raised machine height of 45 mm is standard for rear chip discharge.

<LU4000 EX>

Machine Specifications

Item	unit	LU4000 EX (L)					LU4000 EX (M)					LU4000 EX (MY)						
		2ST	2SC × 650	2SC × 1250	2SC × 2000	2SC × 3000	2ST	2SC × 650	2SC × 1250	2SC × 2000	2SC × 3000	2ST	2SC × 650	2SC × 1250	2SC × 2000	2SC × 3000		
Capacity	Swing over bed	mm (in) ø695 (ø27.36)										mm (in) ø695 (ø27.36)						
	Max turning dia, upper/lower	mm (in) U: ø480/L: ø310 (U: ø18.90/L: ø12.20)										mm (in) U: ø430/L: ø280 (U: ø16.93/L: ø11.02)						
	Max work length	400 (15.75)	650 (25.59)	1,250 (49.21)	2,080 (81.89)	3,080 (121.26)	400 (15.75)	650 (25.59)	1,250 (49.21)	2,080 (81.89)	3,080 (121.26)	400 (15.75)	650 (25.59)	1,250 (49.21)	2,080 (81.89)	3,080 (121.26)		
Travels	X-axis, upper/lower	mm (in) U: 300/L: 195 (U: 11.81/L: 7.68)										mm (in) U: 300/L: 195 (U: 11.81/L: 7.68)						
	Z-axis, upper/lower	U: 740/L: 700 (U: 29.13/L: 27.56)		U: 1,340/L: 1,300 (U: 52.76/L: 51.18)		U: 2,140/L: 2,100 (U: 84.25/L: 82.68)		U: 3,140/L: 3,100 (U: 123.62/L: 122.05)		U: 740/L: 700 (U: 29.13/L: 27.56)		U: 1,340/L: 1,300 (U: 52.76/L: 51.18)		U: 2,140/L: 2,100 (U: 84.25/L: 82.68)		U: 3,140/L: 3,100 (U: 123.62/L: 122.05)		
	Y-axis	mm (in) -										mm (in) -						
	C-axis (minimum control angle)	deg -										deg 360 (0.001)						
Spindle	Speed	min ⁻¹ 42 to 4,200 [30 to 3,000]										min ⁻¹ 42 to 4,200 [30 to 3,000]						
	Speed ranges	Two auto ranges (motor coil switching ranges)										Two auto ranges (motor coil switching ranges)						
	Spindle noze	JIS A2-8 [JIS A2-11]										JIS A2-8 [JIS A2-11]						
	Bore dia	mm (in) ø91 [ø112] (ø3.58 [ø4.41])										mm (in) ø91 [ø112] (ø3.58 [ø4.41])						
	Front bearing dia	mm (in) ø140 [ø160] (ø5.51 [ø6.30])										mm (in) ø140 [ø160] (ø5.51 [ø6.30])						
Turret	Type, upper/lower	U: V12/L: V10										U: Multitasking V12/L: V10 (L radial)						
	No. of tools, upper/lower	tools U: 12/L: 10										tools U: 12 (L/M)/L: 10						
	OD tool shank height	mm (in) □25 (0.98)										mm (in) □25 (0.98)						
	ID tool shank dia	mm (in) ø40 (ø1.57)										mm (in) ø40 (ø1.57)						
	Turret index time	sec/1 index 0.23										sec/1 index 0.23						
Milling tool spindle	Spindle speed	min ⁻¹ -										min ⁻¹ 45 to 6,000						
Feed rate	Rapid traverse	X: 25, Z: 30 (X: 82, Z: 98)				X: 25, Z: 20 (X: 82, Z: 66)		X: 25, Z: 30 (X: 82, Z: 98), C: 200min ⁻¹			X: 25, Z: 20 (X: 82, Z: 66), C: 200min ⁻¹		X: 25, Z: 30 (X: 82, Z: 98), Y: 12.5 (Y: 41), C: 200min ⁻¹			X: 25, Z: 20, Y: 12.5 (X: 82, Z: 66, Y: 41), C: 200min ⁻¹		
Tailstock	Quill dia	mm (in) -										mm (in) ø120 (ø4.72)						
	Quill bore taper	- MT No. 5 (revolving center) [MT No. 5 (built-in)]										- MT No. 5 (revolving center) [MT No. 5 (built-in)]						
	Quill travel	mm (in) -										mm (in) 150 (5.91)						
Motor	Spindle	kW (hp) 22/15 (30/20) (30 min/cont) [32/22 (43/30) (20 min/cont)]										kW (hp) 22/15 (30/20) (30 min/cont) [32/22 (43/30) (20 min/cont)]						
	Milling tool	kW (hp) -										kW (hp) 7.5/4.3 (10/5.7) (25 min/cont)						
	Axis drive	XA:3.5 (4.7), XB: 3.0 (4), ZA: 4.6 (6.1), ZB:4.6 (6.1)				XA:3.5 (4.7), XB: 3.0 (4), ZA: 5.2 (6.9), ZB:5.2 (6.9)		XA:3.5 (4.7), XB: 3.0 (4), ZA: 4.6 (6.1), ZB:4.6 (6.1)			XA:3.5 (4.7), XB: 3.0 (4), ZA: 5.2 (7), ZB:5.2 (7)		XA:3.5 (4.7), XB: 3.0 (4), Ys: 3.5 (4.7), ZA: 4.6 (6.1), ZB:4.6 (6.1)			XA:3.5 (4.7), XB: 3.0 (4), Ys:3.5 (4.7), ZA: 5.2 (6.9), ZB:5.2 (6.9)		
	Coolant pump (50 Hz/60 Hz)	kW (hp) 0.55/0.75 (0.7/1)				0.55/0.75 (0.7/1) ×2		0.55/0.75 (0.7/1)			0.55/0.75 (0.7/1) ×2		0.55/0.75 (0.7/1)			0.55/0.75 (0.7/1) ×2		
Machine size	Height*	2,200 (86.61) *		2,440 (96.06)		2,309 (90.91)		2,200 (86.61) *		2,440 (96.06)		2,309 (90.91)		2,587 (101.85) *		2,770 (109.06)		2,639 (103.90)
	Floor space	3,570 × 2,310 (140.55 × 90.94)		4,780 × 2,620 (188.19 × 103.15)		6,480 × 2,837 (255.12 × 111.69)		8,405 × 2,471 (330.91 × 97.28)		3,570 × 2,310 (140.55 × 90.94)		4,780 × 2,620 (188.19 × 103.15)		6,480 × 2,837 (255.12 × 111.69)		8,405 × 2,471 (330.91 × 97.28)		3,570 × 2,310 (140.55 × 90.94)
	Mass (w/ CNC)	9,000 (19,800)	9,600 (21,120)	11,400 (25,080)	14,500 (31,900)	17,500 (38,500)	9,100 (20,020)	9,700 (21,340)	11,500 (25,300)	14,500 (31,900)	17,500 (38,500)	9,600 (21,120)	10,200 (22,440)	12,000 (26,400)	15,000 (33,000)	18,000 (39,600)		
CNC	OSP-P300LA										OSP-P300LA							

[] : option * Raised machine height of 70 mm is standard for rear chip discharge.

<LU3000 EX>

Standard Specification

	L		M/MY		2M/2MY		W	MW	2MW
	2ST	2SC	2ST	2SC	2ST	2SC	2SW		
Spindle									
JIS A2-6 50 to 5,000 min ⁻¹					●				
Integral 22/15 kW (30 min/cont)									
Sub-spindle									
ø140 flat 50 to 6,000 min ⁻¹								●	
Integral 7.5/5.5 kW (20 min/cont)									
Turret									
Upper V12 + lower V8	●						●		
Upper multitasking V12 + lower V8			●					●	
Upper multitasking V12 + lower multitasking V8					●				●
Milling tool spindle									
45 to 6,000 min ⁻¹			●		●			●	●
7.1/4.1 kW (25 min/cont)									
Tailstock									
Dead hydraulic MT No. 5		●		●		●			
Manual tow-along		●		●		●			
Accessories									
Hydraulic unit					●				
Coolant system					●				
Full-enclosure shielding					●				
Work lamp (LED)					●				
Chuck foot switch					●				
Tailstock quill foot switch		●		●		●			
Lubrication monitor					●				
CNC	OSP-P300LA								

Chucking Kit

	A	B	C	D	E
N-08 Kit A solid 8 in	1	—	—	—	—
N-08 Kit B solid 8 in	—	1	—	—	—
B-208 Kit C hollow 8 in, hole dia ø52 mm	—	—	1	—	—
B-210 Kit D hollow 10 in, hole dia ø70 mm	—	—	—	1	—
BR08* Kit E hollow 8 in, for Big-Bore spindle, hole dia ø66 mm	—	—	—	—	1
Standard soft jaw A	—	5	5	5	5
Standard soft jaw B	—	3	3	3	3
Standard hard jaw	—	1	1	1	1

Note: Special 'Tnut-Plus' (option) T-nuts maintain improved "jaw change accuracy" with formed jaws, and are available alternatives for the BR chuck standard T-nuts. ('Tnut-Plus' T-nuts do not improve workpiece gripping accuracy.)

<LU4000 EX>

Standard Specification

	L		M/MY	
	2ST	2SC	2ST	2SC
Spindle				
JIS A2-8 42 to 4,200 min ⁻¹			●	
Integral 22/15 kW (30 min/cont)				
Turret				
Upper V12 + lower V10	●			
Upper multitasking V12 + lower V10			●	
Milling tool spindle				
45 to 6,000 min ⁻¹			●	
7.5/4.3 kW (25 min/cont)			●	
Tailstock				
Dead hydraulic MT No. 5		●		●
Manual tow-along		●		●
Accessories				
Hydraulic unit			●	
Coolant system			●	
Full-enclosure shielding			●	
Work lamp (LED)			●	
Chuck foot switch			●	
Tailstock quill foot switch		●		●
Lubrication monitor			●	
CNC	OSP-P300LA			

Chucking Kit

	A	B	C	D	E
N-10 Kit A solid 10 in	1	—	—	—	—
N-10 Kit B solid 10 in	—	1	—	—	—
B-210 Kit C hollow 10 in, hole dia ø70 mm	—	—	1	—	—
B-212 Kit D hollow 12 in, hole dia ø81 mm	—	—	—	1	—
BR10* Kit E hollow 10 in, for Big-Bore spindle, hole dia ø81 mm	—	—	—	—	1
Standard soft jaw A	—	5	5	5	5
Standard soft jaw B	—	3	3	3	3
Standard hard jaw	—	1	1	1	1

Note: Special 'Tnut-Plus' (option) T-nuts maintain improved "jaw change accuracy" with formed jaws, and are available alternatives for the BR chuck standard T-nuts. ('Tnut-Plus' T-nuts do not improve workpiece gripping accuracy.)

Optional Equipment & Accessories

Big-Bore spindle	LU3000 EX JIS A2-8 42 to 4,200 min ⁻¹ Front bearing dia ø140 mm Spindle bore dia ø91 mm	Front door with large window For air blower (blast)	Chuck
	LU4000 EX JIS A2-11 30 to 3,000 min ⁻¹ Front bearing dia ø160 mm Spindle bore dia ø112 mm		Tailstock center Spindle ID Upper turret (internal piping, common coolant nozzle) Lower turret (common coolant nozzle) Upper/lower turret air blower discharge control (simultaneous, independent)
Super Big-Bore spindle	LU3000 EX JIS A2-11 30 to 3,000 min ⁻¹ Front bearing dia ø160 mm Spindle bore dia ø112 mm	For coolant blower	Coolant gun Shower coolant (A, B) Spindle ID coolant (main, A, B)
High-Power spindle	LU4000 EX 32/22 kW (20 min/cont)	Dust proofing	Spindle air purging X-axis double wiper (XA) [Standard for XB] Z-axis double wiper (ZA + ZB)
			Gauging-related options
L-VDI turret		Workrest	
Live quill hydraulic tailstock	LU3000 EX MT No. 4	Stopper in spindle	
	LU4000 EX MT No. 5	Chuck internal sizing stopper	
Programmable tailstock		Coolant	Upper/lower turret coolant blower discharge control (independent) Coolant high/low switch (upper, lower turret) Coolant detection (level, flow rate, level + flow rate detectors)
Chucking kit	Solid/hollow hydraulic power chuck, soft jaws		
Tooling kit	Various toolholders	Mist collector	With/without machine link
Raised machine height	50 mm, 100 mm, 150 mm	Parts catcher	LU3000 EX Main (ø80 × L150 mm, 5.8 kg) Sub (ø65 × L150 mm, 4 kg)
			LU4000 EX ø100 × L200 mm, 7 kg
Chip discharge	Chip pan Chip conveyor (side discharge/rear discharge) Chip bucket	Optional high-accuracy specifications	Turcite® lining (XA-axis, ZA-axis, ZB-axis) AbsoScale (XA-axis, ZA-axis, XB-axis) Coolant temperature regulator Spindle temperature regulator Hydraulic oil temperature regulator
Touch Setter	M (manual), A (auto)		
Steadyrest			
Automation	On-machine loader, gantry loader		
	Robot, bar feeder		
Front cover	Front cover auto open/close (safety tape SW, area sensor)		
	Two-hand cycle start button		
For chucking	Chuck auto open/close confirm		
	Chucking miss detection (main, sub)		
	Chuck high/low pressure switch with reclamping (main, sub)		
For tailstock	LU3000 EX Tailstock travel 230 mm		
	LU4000 EX Tailstock travel 260 mm		
	Tailstock quill auto advance/retract with confirm		
	Tailstock thrust high/low switch		
	Low tailstock thrust		
	Tailstock quill position detection 2-speed tailstock quill High tailstock thrust (LU4000 EX only)		

<LU3000 EX>

Tooling Kit

	LU3000 EX (L)				LU3000 EX (M/MY)			
	2ST		2SC		2ST		2SC	
	E	D	E	D	E	D	E	D
OD-I	6	8	8	10	6	8	6	8
OD-II	4	6	2	4	2	4	2	4
ID-H40	8	10	8	10	8	10	8	10
BS 10-H40	—	2	—	2	—	2	—	2
BS 12-H40	—	2	—	2	—	2	—	2
BS 16-H40	—	2	—	2	—	2	—	2
BS 20-H40	4	4	4	4	4	4	4	4
BS 25-H40	4	4	4	4	4	4	4	4
BS 32-H40	—	2	—	2	—	2	—	2
DS MT No. 1-H40	—	1	—	1	—	1	—	1
DS MT No. 2-H40	—	1	—	1	—	1	—	1
DS MT No. 3-H40	1	1	1	1	1	1	1	1
Axial drill/mill unit					2	4	2	3
Radial drill/mill unit					2	3	2	4
Dummy holder					3	3	3	3
Revolving center MT No. 5	—	—	1	1	—	—	1	1

E Kit: Economy
D Kit: Deluxe

Tooling System

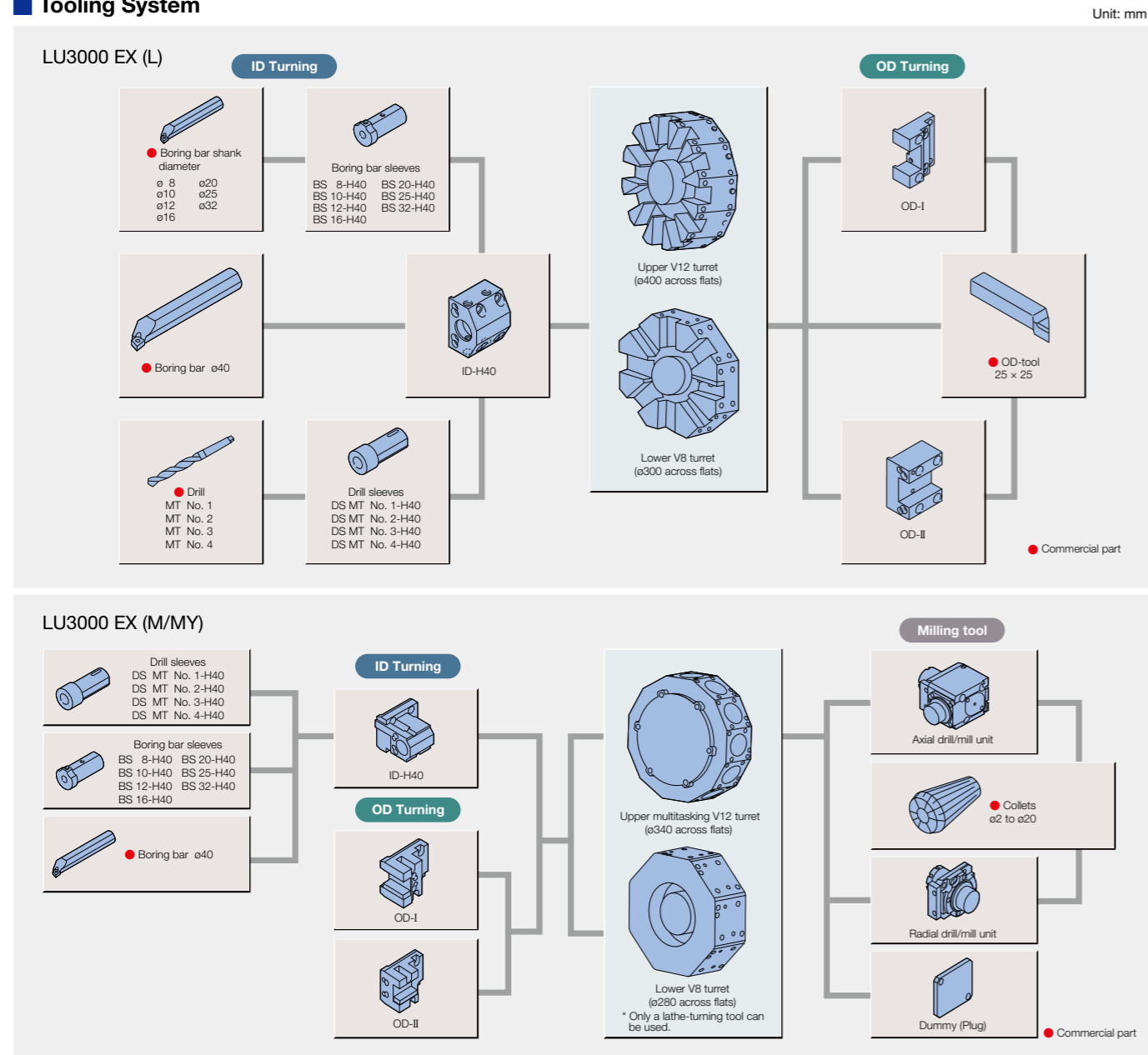

Tooling System

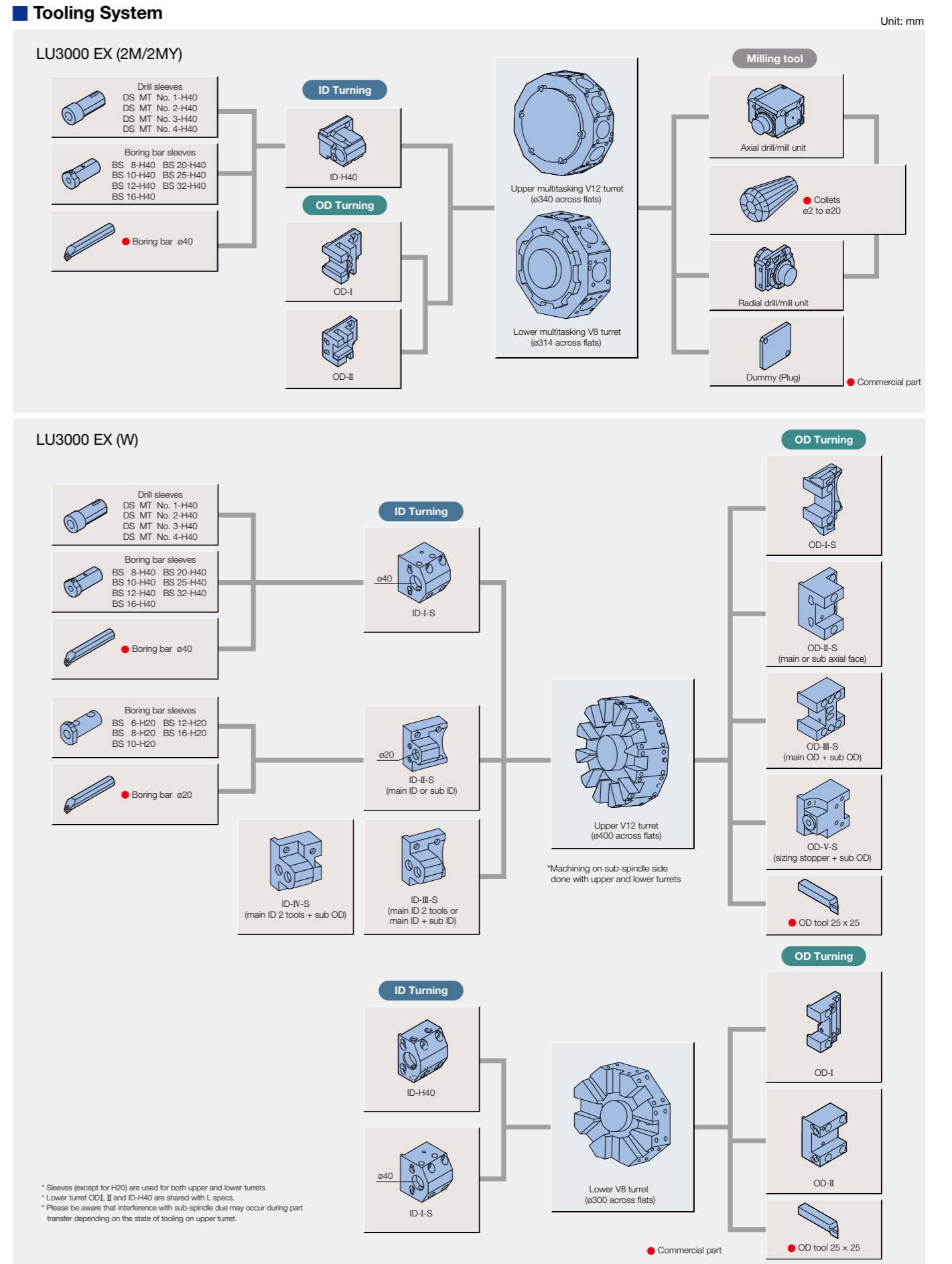

Tooling System

Unit: mm

LU3000 EX (MW/2MW) Upper turret

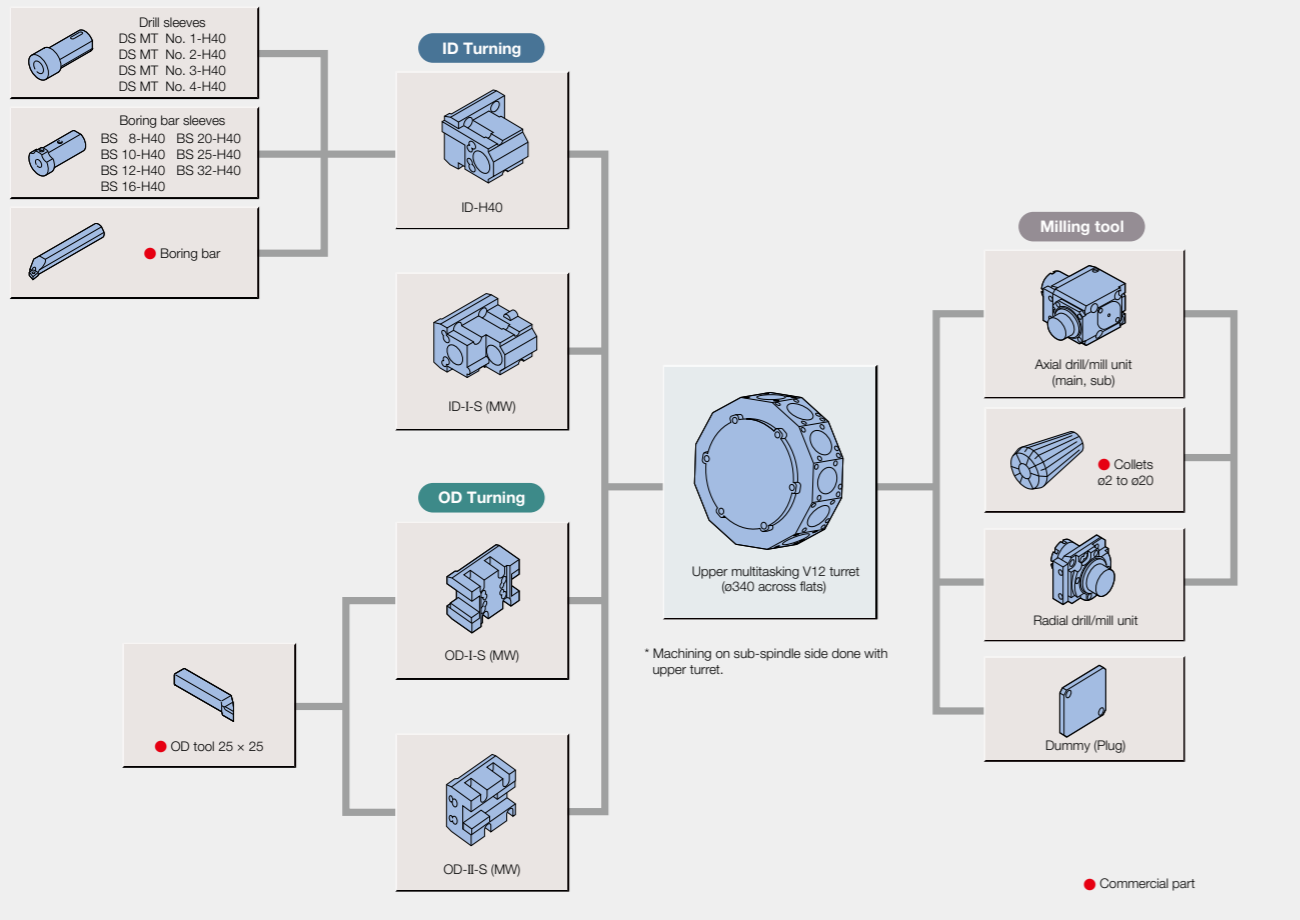

LU3000 EX (MW) Lower turret

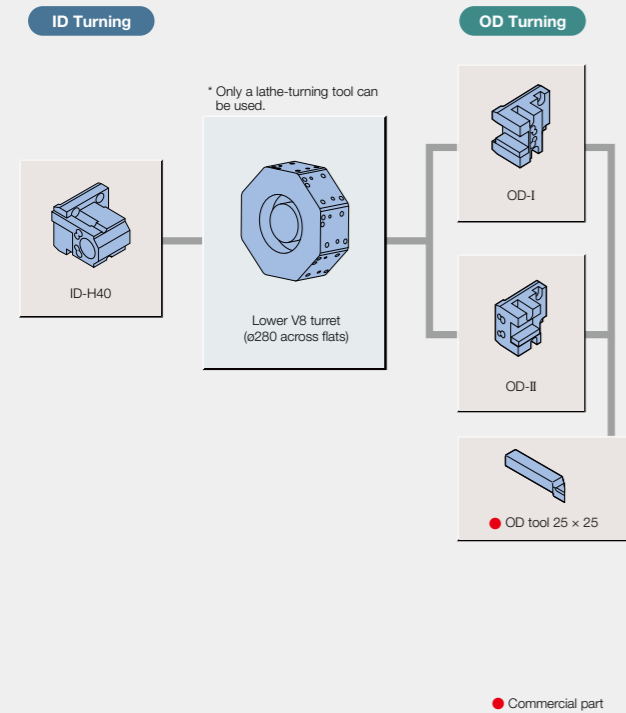

LU3000 EX (2MW) Lower turret

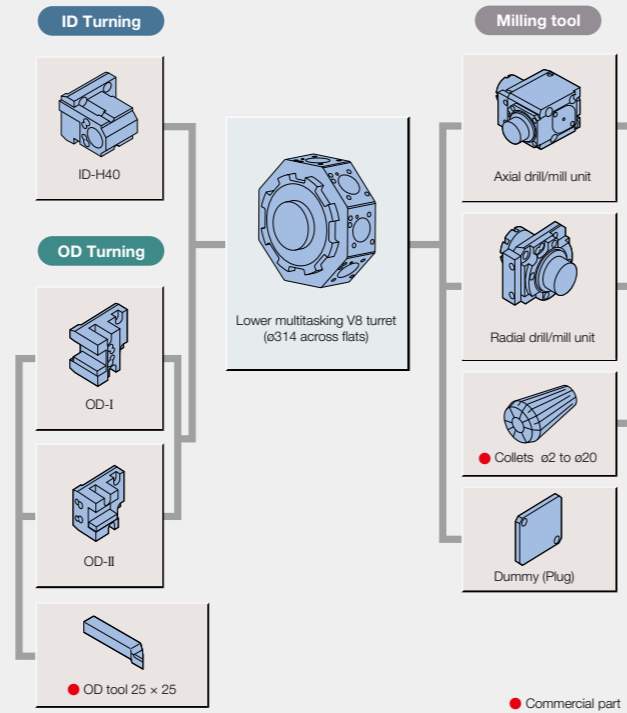

<LU4000 EX>

Tooling Kit

	LU4000 EX				LU4000 EX (M/MY)			
	2ST		2SC		2ST		2SC	
	E	D	E	D	E	D	E	D
OD-I	6	8	8	10	6	8	6	8
OD-II	4	6	2	4	2	4	2	4
ID-H40	8	10	8	10	8	10	8	10
BS 10-H40	-	2	-	2	-	2	-	2
BS 12-H40	-	2	-	2	-	2	-	2
BS 16-H40	-	2	-	2	-	2	-	2
BS 20-H40	4	4	4	4	4	4	4	4
BS 25-H40	4	4	4	4	4	4	4	4
BS 32-H40	-	2	-	2	-	2	-	2
DS MT No. 1-H40	-	1	-	1	-	1	-	1
DS MT No. 2-H40	-	1	-	1	-	1	-	1
DS MT No. 3-H40	1	1	1	1	1	1	1	1
Axial drill/mill unit					2	4	2	3
Radial drill/mill unit					2	3	2	4
Dummy holder					3	3	3	3
Revolving center MT No. 5	-	-	1	1	-	-	1	1

E Kit: Economy
D Kit: Deluxe

Tooling System

Unit: mm

LU4000 EX (L)

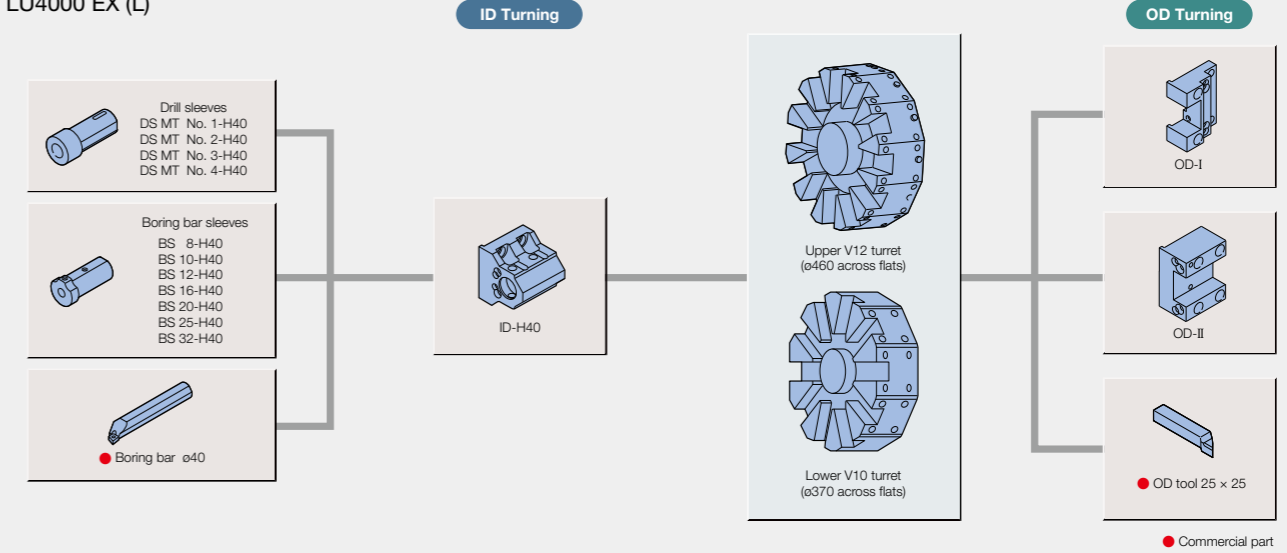

LU4000 EX (M/MY)

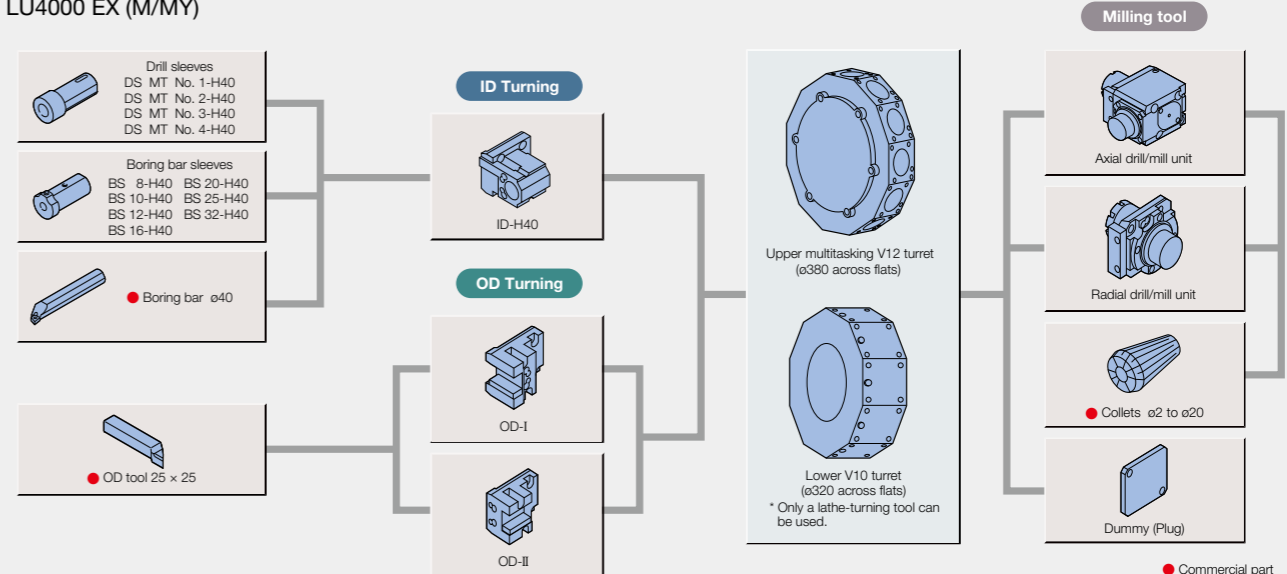

<LU3000 EX>

Working Ranges

LU3000 EX (L)

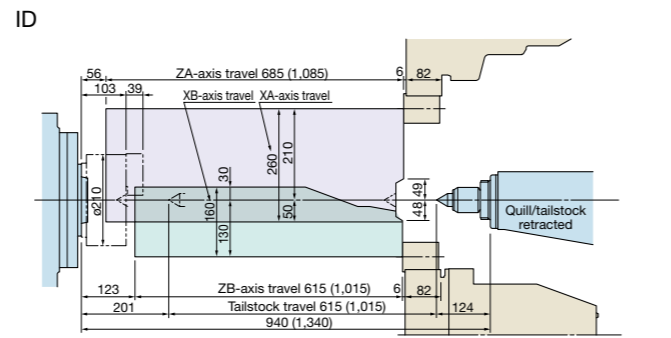
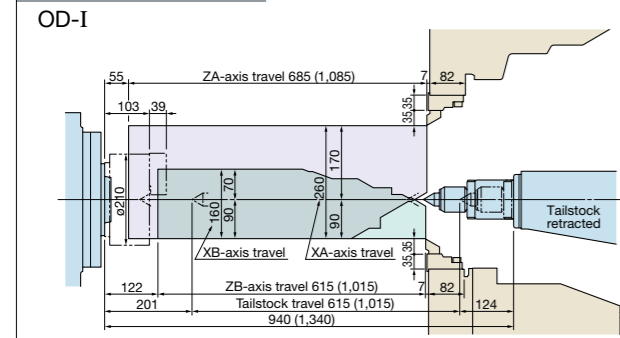

LU3000 EX (M)

Axial drill/mill unit

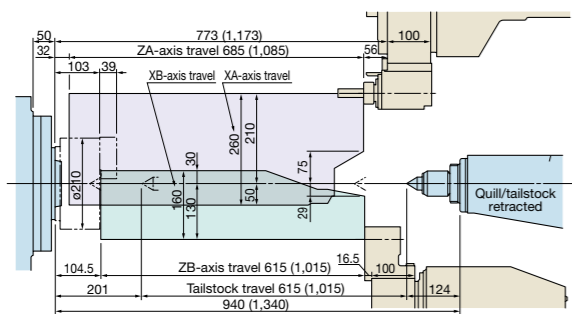

Radial drill/mill unit

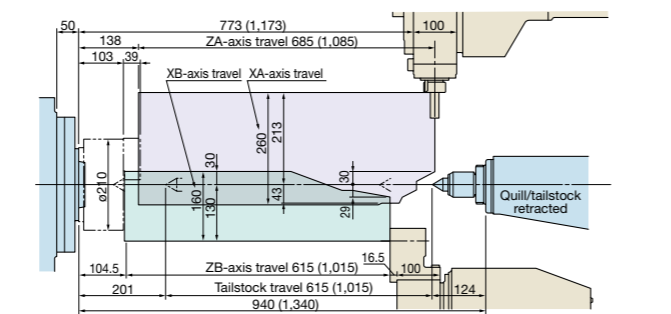

LU3000 EX (MY)

Axial drill/mill unit Y=0

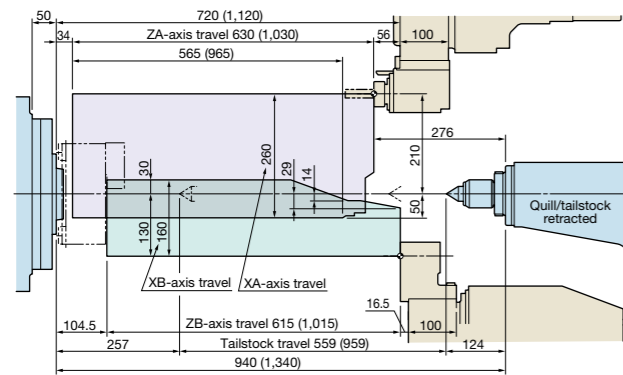

Radial drill/mill unit Y=0

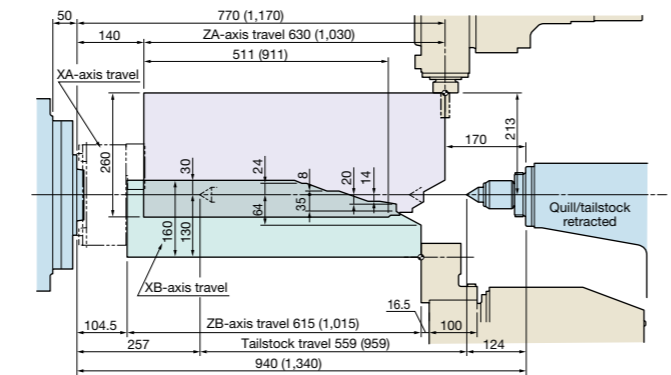

LU3000 EX (W)

OD-III-S

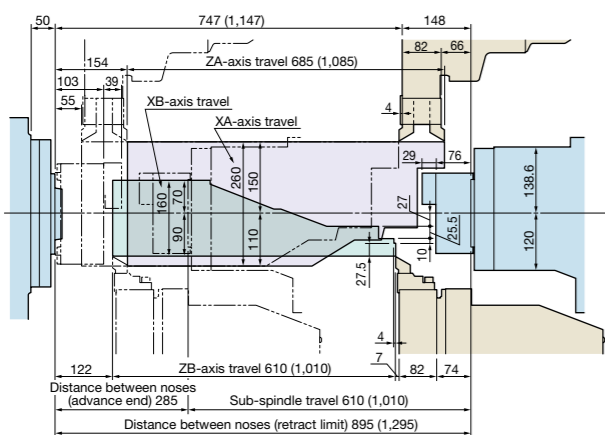

ID-III-S

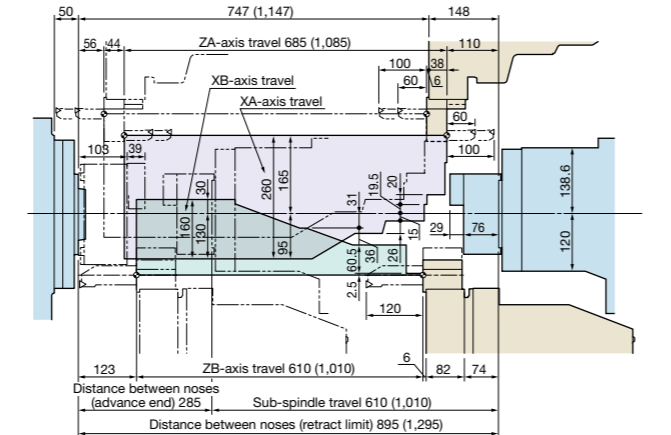

LU3000 EX (2M)

Axial drill/mill unit

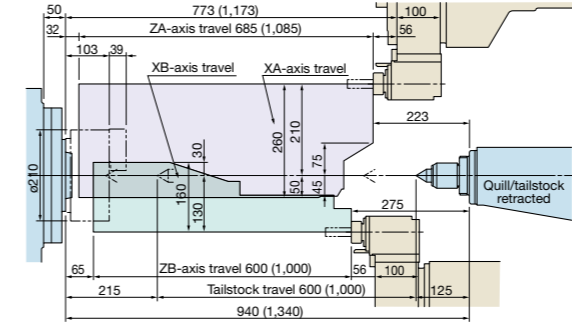

This drawing refers to the 600 DBC machine specifications. () : Distance between centers 1000.

Radial drill/mill unit

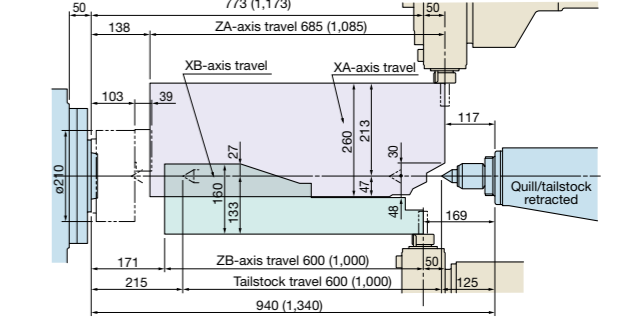

LU3000 EX (2MY)

Axial drill/mill unit Y=0

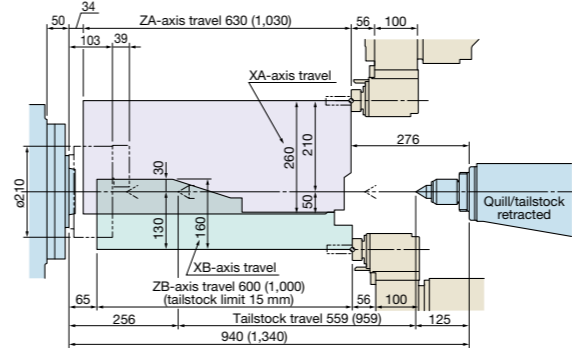

This drawing refers to the 550 DBC machine specifications. () : Distance between centers 950.

Radial drill/mill unit Y=0

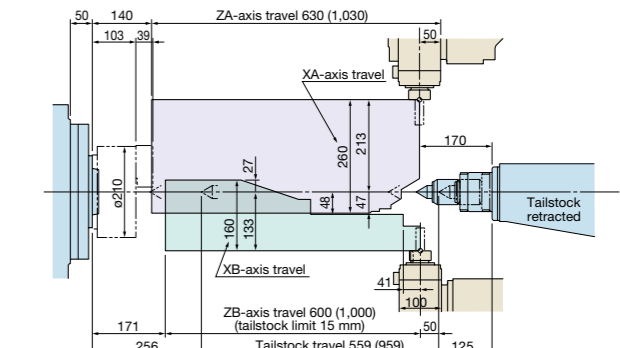

LU3000 EX (MW)

Axial drill/mill unit

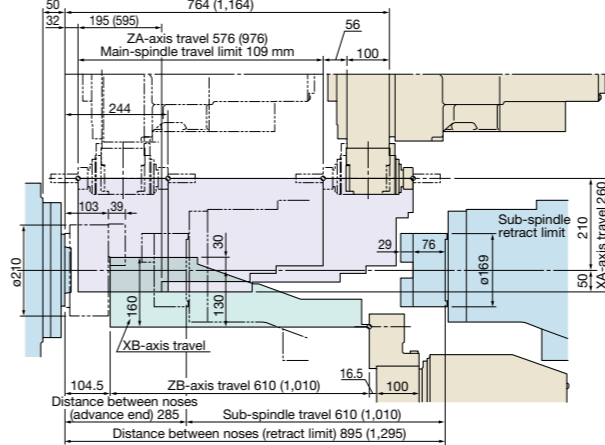

This drawing refers to the 600 DBC machine specifications. () : Distance between centers 1000.

Radial drill/mill unit

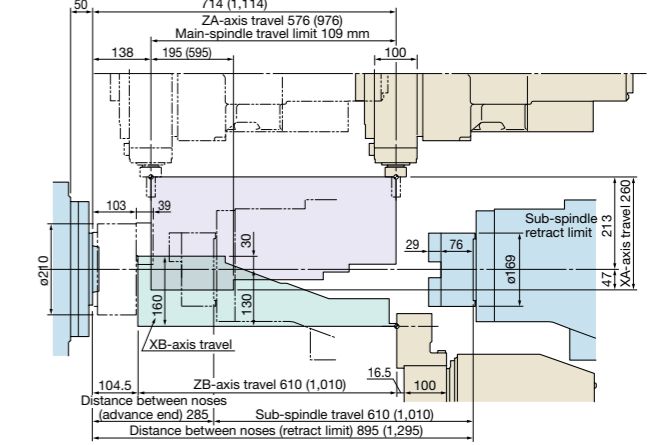

LU3000 EX (2MW)

Axial drill/mill unit

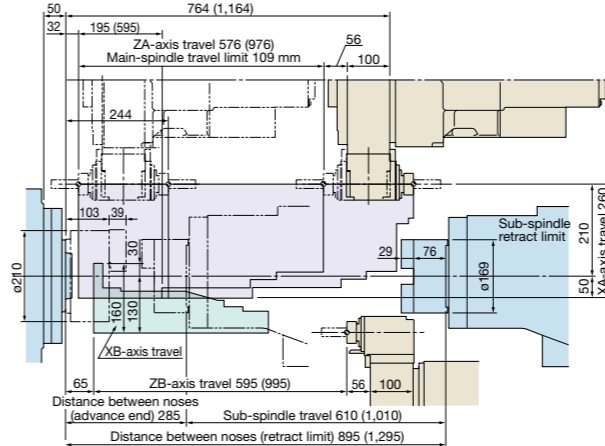

This drawing refers to the 600 DBC machine specifications. () : Distance between centers 1000.

Radial drill/mill unit

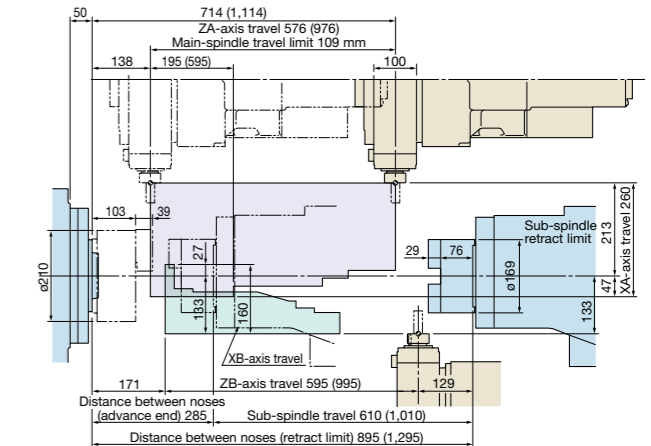

<LU4000 EX>

Working Ranges

Unit: mm

LU4000 EX (L)

OD-I

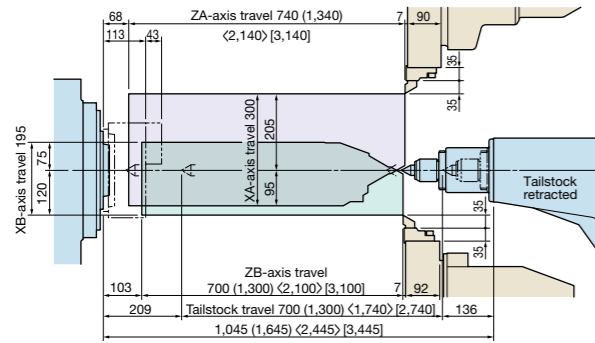

ID

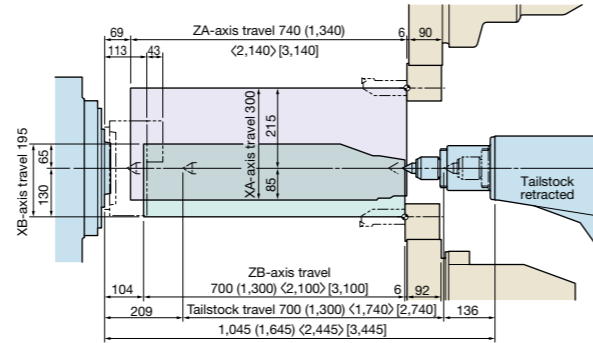

This drawing refers to the 650 DBC machine specifications.
 () : Distance between centers 1250.
 < > : Distance between centers 2000.
 [] : Distance between centers 3000.

LU4000 EX (M)

Axial drill/mill unit

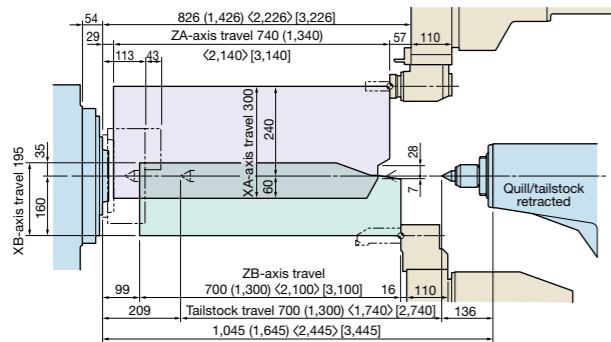

Radial drill/mill unit

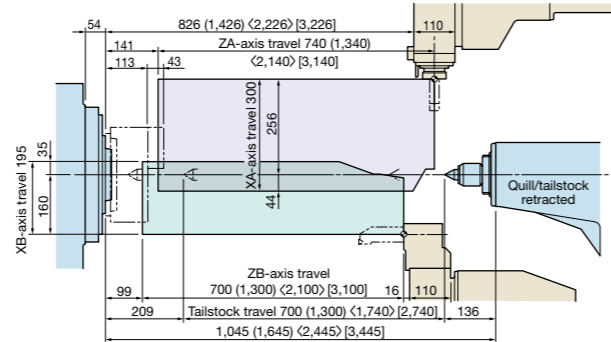

This drawing refers to the 650 DBC machine specifications.
 () : Distance between centers 1250.
 < > : Distance between centers 2000.
 [] : Distance between centers 3000.

LU4000 EX (MY)

Axial drill/mill unit Y=0

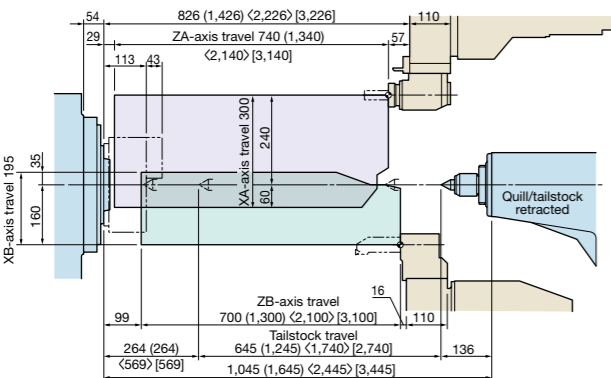

Radial drill/mill unit Y=0

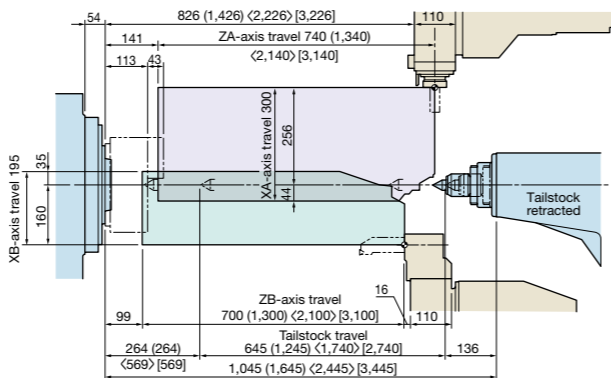

This drawing refers to the 650 DBC machine specifications.
 () : Distance between centers 1250.
 < > : Distance between centers 2000.
 [] : Distance between centers 3000.

<LU3000 EX>

Turret Interference Diagrams

Unit: mm

LU3000 EX (L)

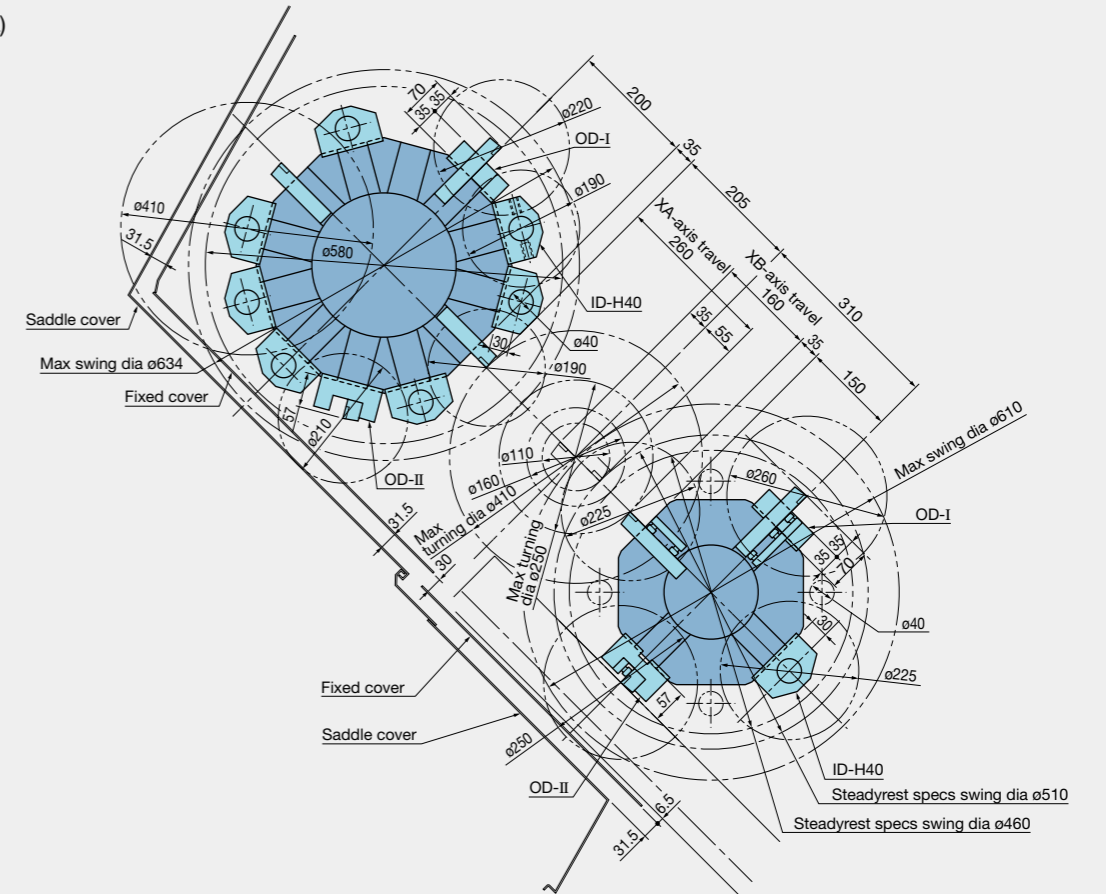

LU3000 EX (M)

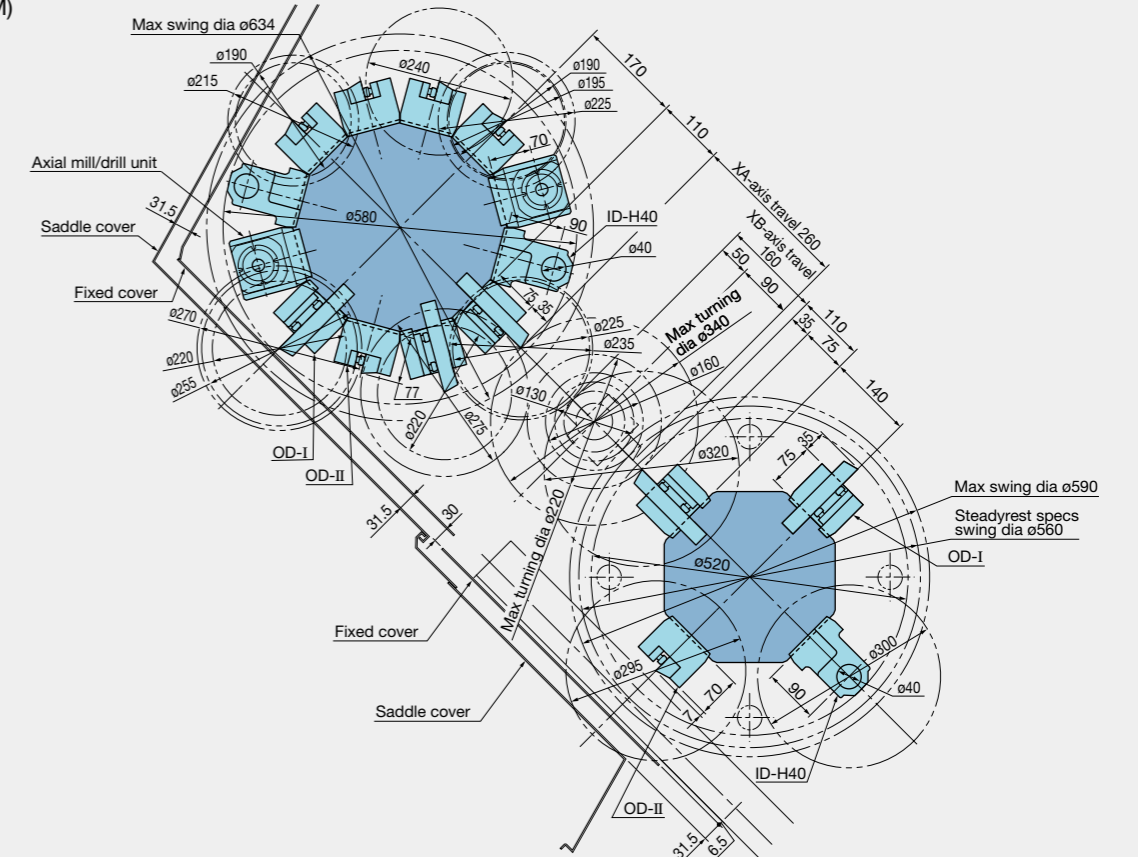

Turret Interference Diagrams

Unit: mm

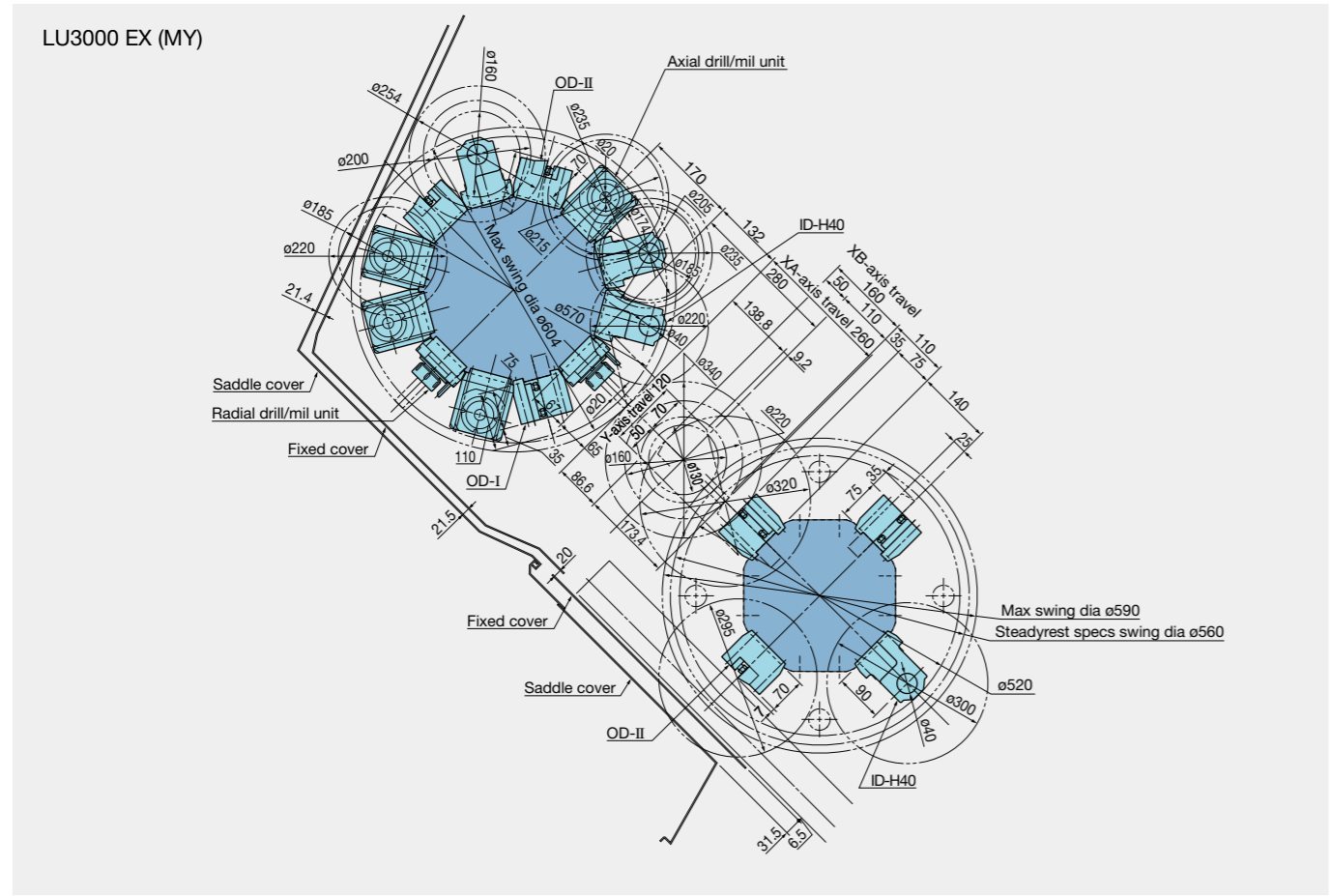

Unit: mm

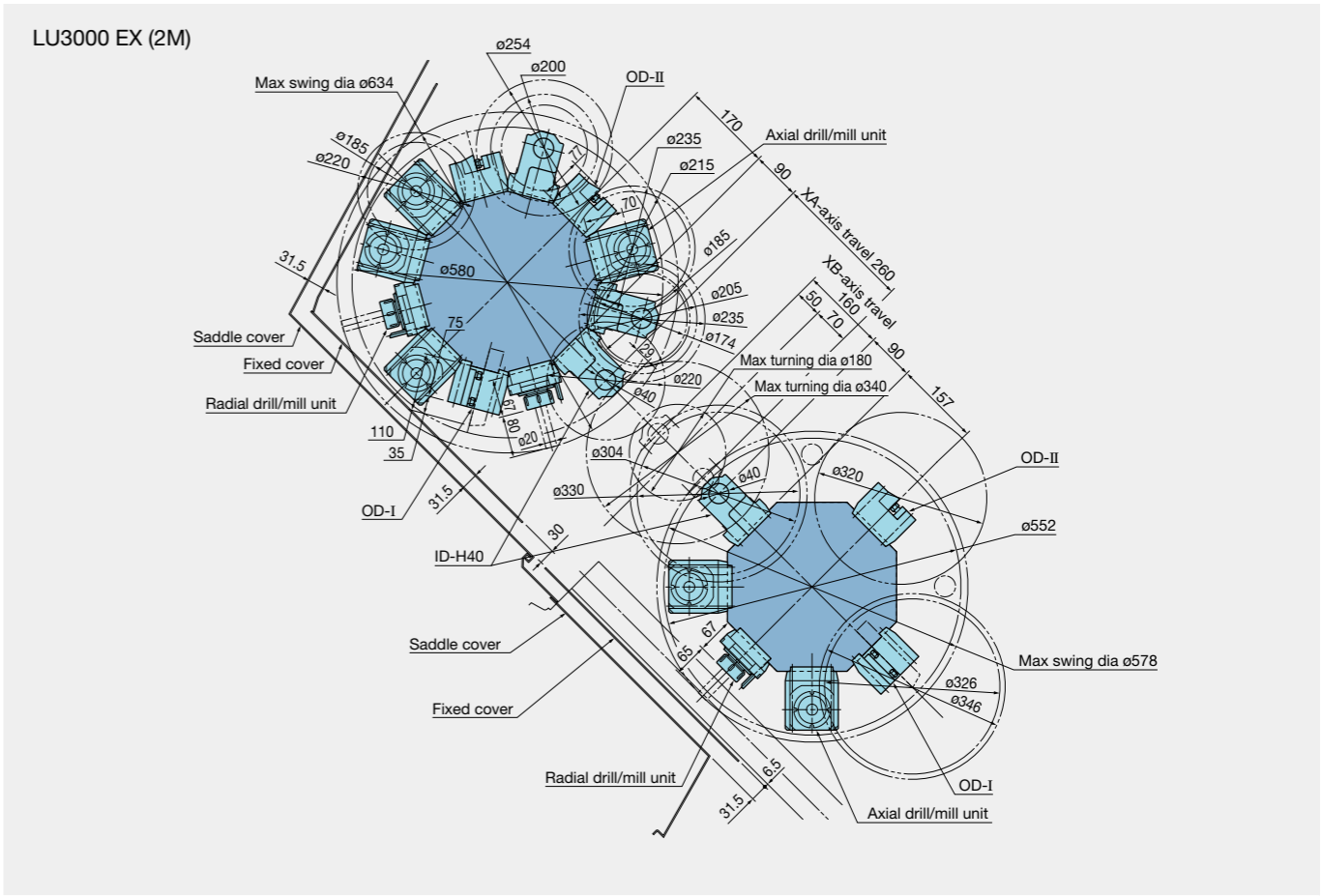

LU3000 EX (W) Main-spindle

LU3000 EX (W) Sub-spindle

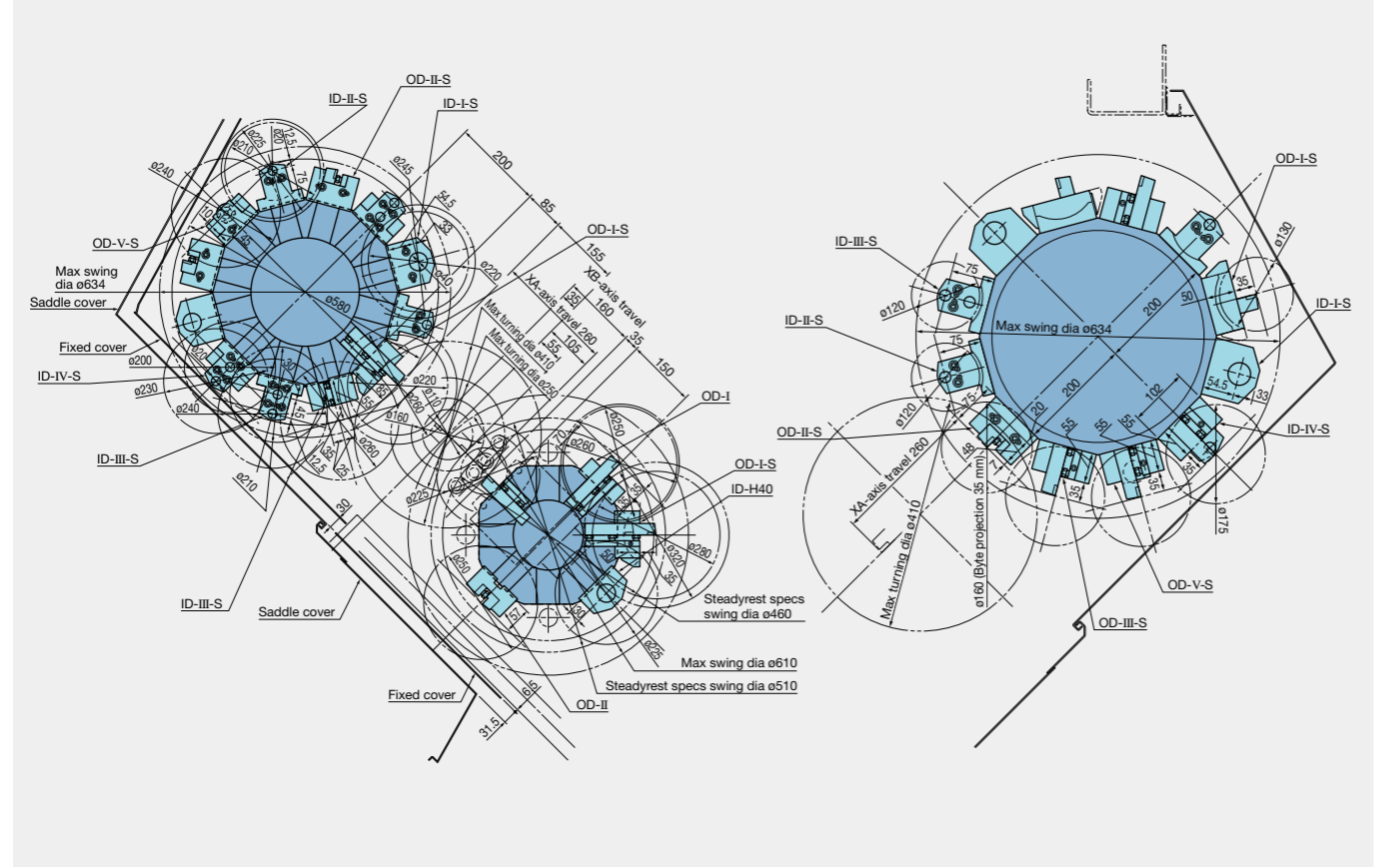

LU3000 EX (2MY)

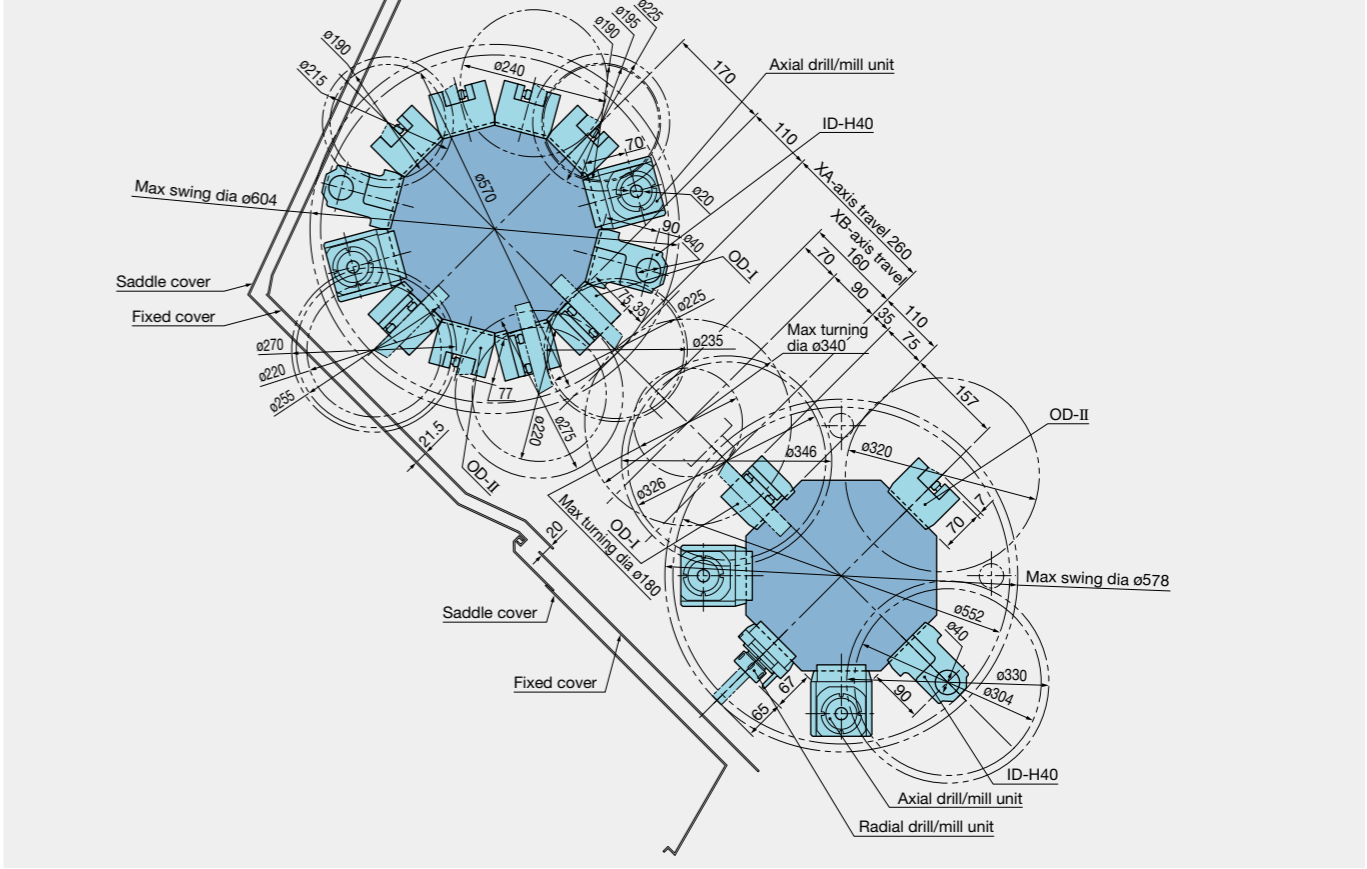

LU4000 EX (L/M) Distance between centers 2000

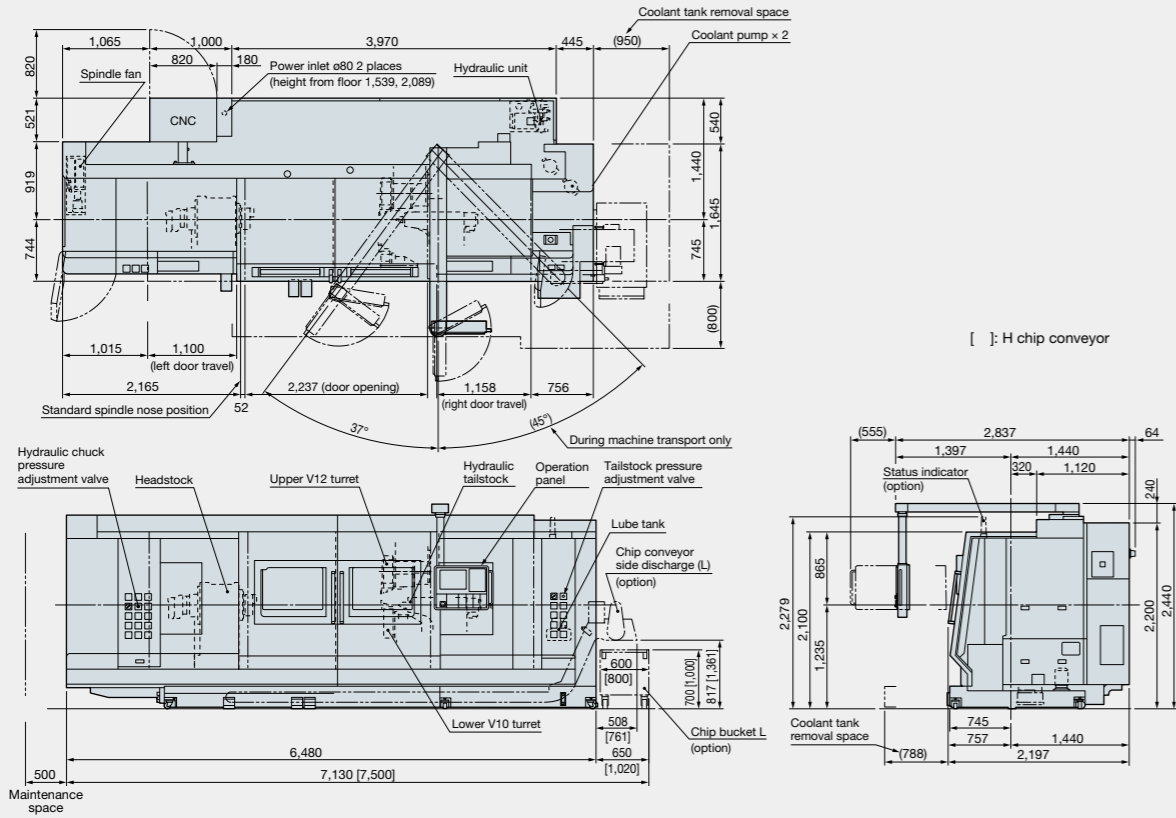

LU4000 EX (MY) Distance between centers 2000

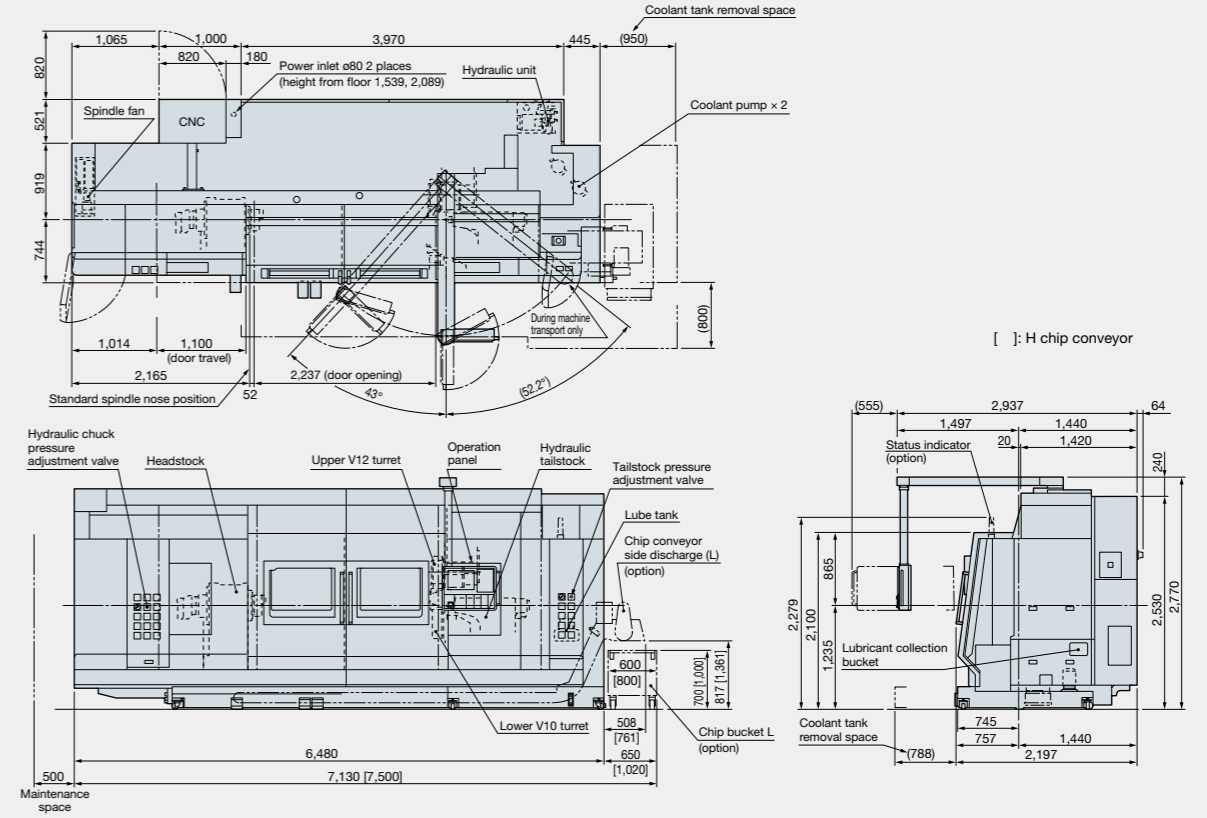

LU4000 EX (L/M) Distance between centers 3000

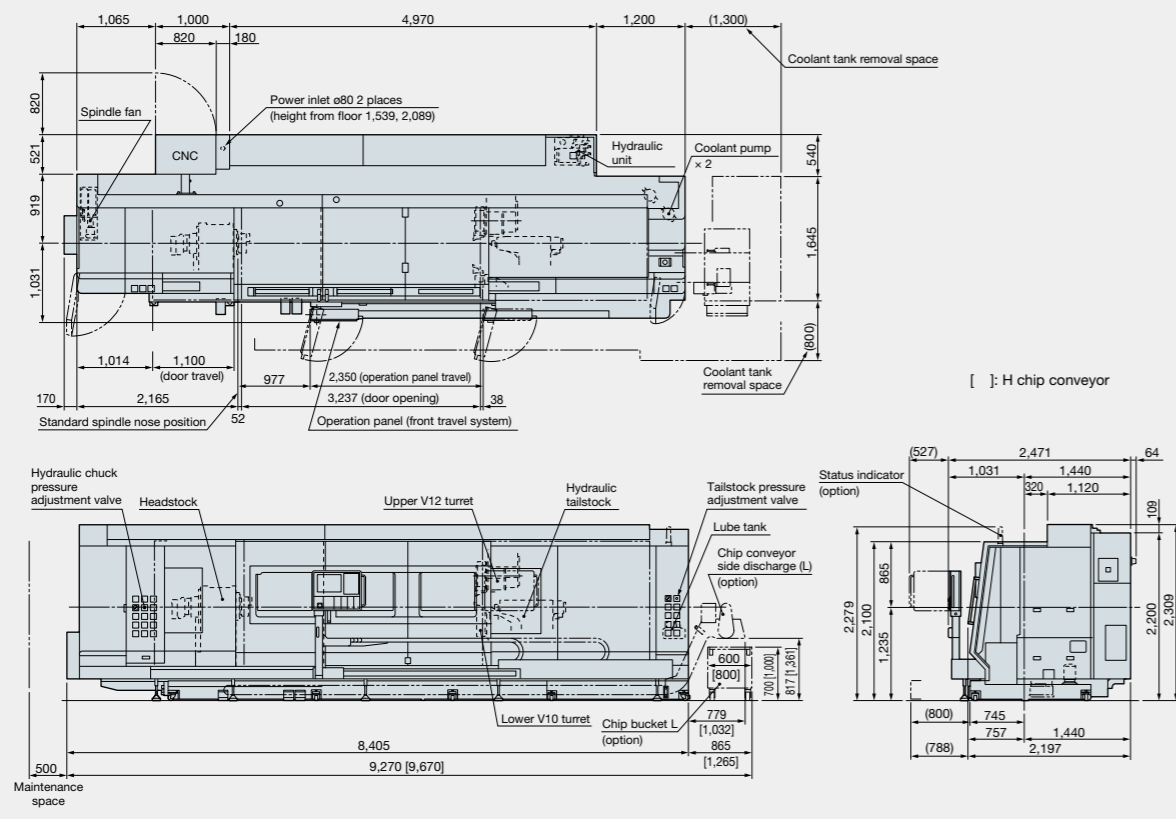

LU4000 EX (MY) Distance between centers 3000

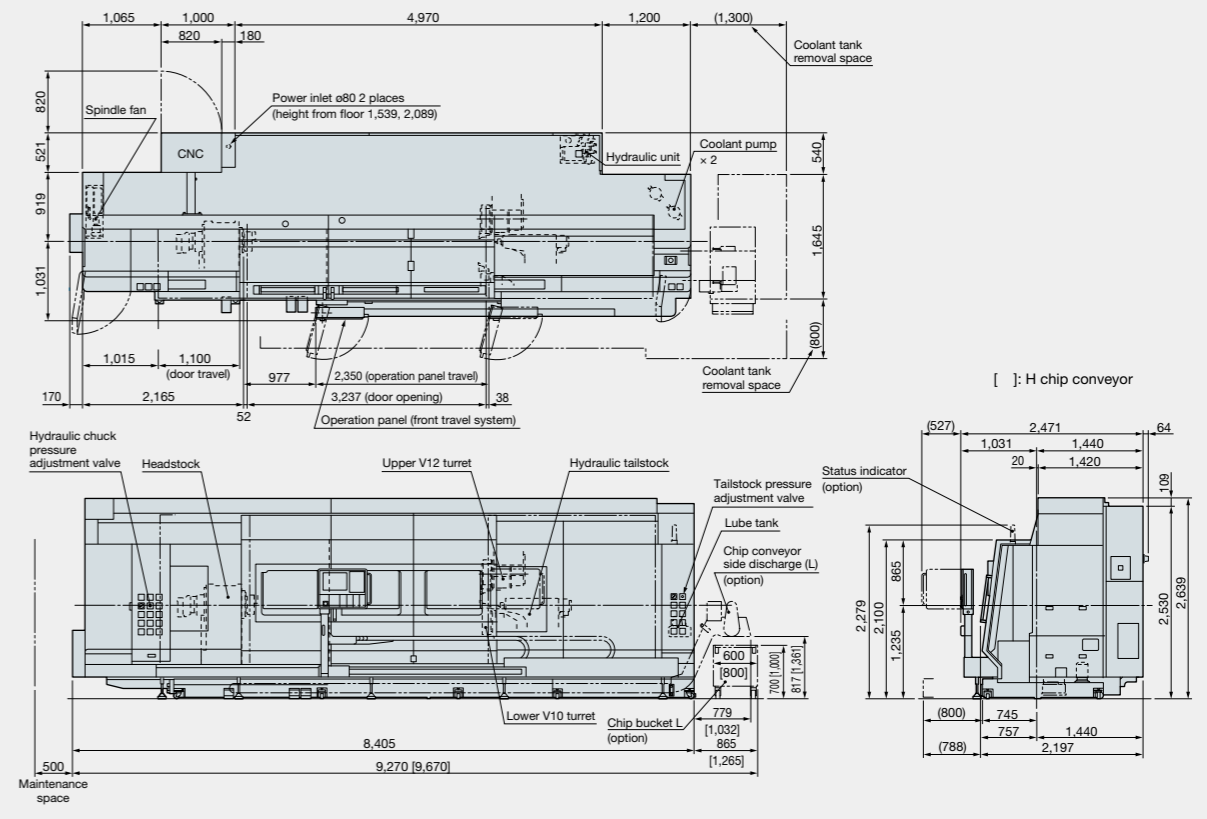

**With revamped operation and responsiveness—
ease of use for machine shops first!**

Smart factories are using advanced digitization and networking (IIoT) in manufacturing to achieve enhanced productivity and added value. The OSP has evolved tremendously as a CNC suited to advanced intelligent technology. Okuma's new control uses the latest CPUs for a tremendous boost in operability, rendering performance, and processing speed. The OSP suite also features a full range of useful apps that could only come from a machine tool manufacturer, making smart manufacturing a reality.

**Smooth, comfortable operation with the feeling
of using a smartphone**

Improved rendering performance and use of a multi-touch panel achieve intuitive graphical operation. Moving, enlarging, reducing, and rotating 3D models, as well as list views of tool data, programs, and other information can be accomplished through smooth, speedy operations with the same feel as using a smartphone. The screen display layout on the operation screen can also be changed to suit operator preferences and customized for the novice and/or veteran machinists.

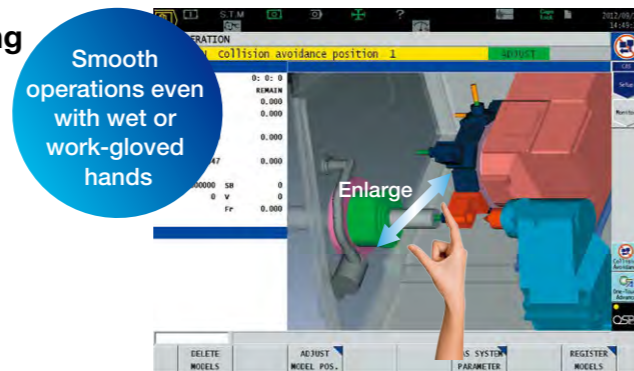

“Just what we wanted.”— Refreshed OSP suite apps

This became possible through the addition of Okuma's machining expertise based on requests we heard from real, machine-shop customers. The brain power packed into the CNC, built by a machine tool manufacturer, will “empower shop floor” management.

Spindle Output Monitor
Increased productivity through visualization of motor power reserve

The specified spindle output (red line: short time rating, green line: continuous rating) and the spindle output in current cutting (blue circle) are simultaneously displayed on the screen, for real-time view of power reserve during cutting. This allows speeding up cutting by increasing the spindle speed or feed rate while monitoring the graph to ensure that the blue circle does not cross the lines.



Scheduled Program Editor
Easy programming without keying in code

E-mail Notification
Monitoring utilization status even when away from the machine

Connect Plan Get Connected, Get Started, and Get Innovative with Okuma “Monozukuri”

Connect, Visualize, Improve

Okuma's Connect Plan is a system that provides analytics for improved utilization by connecting machine tools and visual control of factory operation results and machining records. Simply connect the OSP and a PC and install Connect Plan on the PC to see the machine operation status from the shop floor, from an office, from anywhere. The Connect Plan is an ideal solution for customers trying to raise their machine utilization.

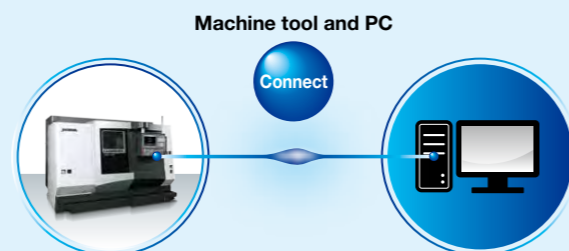

Standard Specifications

Basic Specs	Control	Turning: X, Z simultaneous 2-axis + 2-axis. Multitasking: X, Z, C simultaneous 3-axis
	Position feedback	OSP full range absolute position feedback (zero point return not required)
	Min / Max command	±99999.999 mm, 8-digit decimal, command units: 0.001 mm, 0.01 mm, 1 mm, 0.001°, 0.01°, 1°
	Feed	Override: 0 to 200%
	Spindle control	Direct spindle speed commands override 50 to 200%, constant cutting speed, optimum turning speed designate
	Tool compensation	Tool selection: 32 sets, tool offset: 32 sets
	Display	15-inch color display operational panel, touch panel
	Self-diagnostics	Automatic diagnostics and display of program, operation, machine, and NC system problems
	Program capacity	Program storage: 4 GB, operation buffer: 2 MB
	Operations	“suite apps”
“suite operation”		Highly reliable touch panel suited to shop floors. One-touch access to suite apps.
Easy Operation		“Single-mode operation” to complete a series of operations
Programming		Program management, edit, scheduled programs, fixed cycles, special fixed cycles, tool nose R compensation, M-spindle synchronized tapping, fixed drilling cycles, arithmetic functions, logic statements, trig functions, variables, branch statements, Auto programming (LAP4), programming help
Machine operations		MDI, manual (rapid traverse, pulse handle), load meter, operations help, alarm help, sequence return, manual interrupt & auto return, Data I/O, spindle orientation (electric), easy setting of cycle time reduction
	MacMan	Machining Management: machining results, machine utilization, fault data compile & report, external output
Communications/Networks		USB (2 ports), Ethernet, DNC-T1
High speed/accuracy		Hi-G control, TAS-C (Thermal Active Stabilizer-Construction) (MY specifications only)
Energy-saving function		ECO suite plus ECO Idling Stop, ECO Power Monitor
		Power Regeneration System Regenerative power is used when the spindle and feed axes decelerate to reduce energy waste.

Optional Specifications

Item	Kit specs*1	NML		3D		OT-IGF		OTM	
		E	D	E	D	E	D	E	D
New Operations									
Advanced One-Touch IGF-L *2						●	●		
Advanced One-Touch IGF-L Multitasking *2								●	●
Programming									
Operation buffer 10 MB									
Circular threading			●	●	●	●			
Program notes			●	●	●	●			
User task 2 I/O variables, 8 each									
Work coordinate system select									
Tool compensation (Std: 32 sets)	Tool compensation 64 sets								
	Tool compensation 96 sets								
	Tool compensation 200 sets								
	Tool compensation 999 sets								
Common variables 1,000 sets (Std: 200 sets)									
Thread matching									
Threading slide hold (G34, G35)									
Variable Spindle Speed Threading (VSSST)									
Inverse time feed									
Spindle synchronized tapping (rigid tapping)	Coordinate convert		▲	▲	▲	▲			●
	Profile generate		▲	▲	▲	▲			●
	Flat turning								
	Helical cutting (within 360 degrees)								
	Helical Contour Generation								
	C-axis Torque Skip								
Monitoring									
Real 3-D Simulation				●	●	●	●	●	●
Cycle time over check			●	●	●	●	●	●	●
Load monitor (spindle, feed axis)				●	●	●	●	●	●
Load monitor no-load detection (load monitor ordered)									
Status Logger									
AI machine diagnostics (feed axes) *3				●	●	●			
Tool life management									
Tool life warning									
Operation end buzzer									
Chucking miss detection									Included in machine specs
Workpiece counters	Count only								
	Cycle stop								
	Start disabled								
Hour meters	Power ON								
	Spindle rotation								
	NC operating								
NC operation monitor (counter, totaling)			●	●	●	●	●	●	●
Status indicator (triple lamp) Type C [Type B]			●	●	●	●	●	●	●
Measuring									
In-process workpiece gauging									Included in machine specs
Z-axis automatic zero offset by touch sensor									
C-axis automatic zero offset by touch sensor									
Y-axis gauging									
Gauge data output	File output								
Post-process workpiece gauging interface	Set levels (5-level, 7-level)								
	BCD								
	RS-232C (dedicated channel)								
Touch Setter [M, A]									Included in machine specs
External Input/Output and Communication Functions									
RS-232C connector									
DNC link	DNC-T3								
	DNC-C/Ethernet								
	DNC-DT								
USB (additional)	2 more ports possible								
Automation/Unattended Operation									
Auto power shutoff M02, alarm									
Warm-up function (by calendar timer)									
Tool retract cycle									
External program selections	A (pushbutton) 8 types								
	B (rotary switch) 8 types								
	C1 (digital switch) BCD, 2-digit								
	C2 (external input) BCD, 4-digit								
Okuma loader (OGL) interface									Including loader specs
Third party robot and loader interface *4	Type B (machine)								
	Type C (robot and loader)								
	Type D								
	Type E								
Bar feeders									
Cycle time reduction *4	Operation time reduction		●	●	●	●	●	●	●
	Chuck open/close during spindle rotation								
	Tallstock advance/retract during spindle rotation								
High-Speed/High-Accuracy Functions									
Thermo Active Stabilizer-Construction TAS-C									
0.1 μm control *4									
Pitch error compensation									
Hi-Cut Pro			▲	▲	▲	▲			●
Y-axis center height offset									
Energy-saving function ECO suite plus									
ECO Operation	Chip conveyor intermittent/linked operation								
	Mist collector intermittent/linked operation								
	Spindle Power Peak Limiter								
ECO Power Monitor									Wattmeter
Other Functions									
Collision Avoidance System (CAS)									
One-Touch Spreadsheet									
Machining Navi L-g II, T-g (threading)									
Variable Spindle Speed Control (VSSC)			●	●	●	●	●	●	●
Spindle dead-slow cutting									
Spindle speed setting									
Manual cutting feed									
Short circuit breaker									
External M signals [2 sets, 4 sets, 8 sets, 16 sets]									
Edit interlock									
OSP-VPS (Virus Protection System)									

*1. NML: Normal, 3D: Real 3D Simulation, OT-IGF: One-Touch IGF, OTM: One-Touch M
E: Economy, D: Deluxe
*2. Real 3-D simulation is included
*3. With AbsoScale detection specs, ball screw wear detection is possible.
*4. Engineering discussions required.
Note. ▲Triangle items for M function (milling tool) machines only.

When using Okuma products, always read the safety precautions mentioned in the instruction manual and attached to the product.

● The specifications, illustrations, and descriptions in this brochure vary in different markets and are subject to change without notice.
Pub. SIMUL_TURN LU3000_4000 EX-E-(5b)-100 (Sep 2022)



OKUMA Corporation

Oguchi-cho, Niwa-gun,
Aichi 480-0193, Japan
TEL: +81-587-95-7825 FAX: +81-587-95-6074

This product is subject to the Japanese government Foreign Exchange and Foreign Trade Control Act with regard to security controlled items; whereby Okuma Corporation should be notified prior to its shipment to another country.